

REVISIONS				
P	LTR	DESCRIPTION	DATE	DWN APVD
L		RESIN SUPPLIER CHANGE FOR THE HOUSING	02MAY2022	SCB PS

- 1 POINT OF MEASUREMENT FOR PLATING THICKNESS (INSIDE OF BEAMS).
- 2 TOLERANCE NON-CUMULATIVE.
- 3 THE MATING END OF THE CONTACT IS IDENTIFIED BY THE LETTER "A" STAMPED ON THE RECEPTACLE BOX.
- 4 OBSOLETE PARTS: OBSOLETE CIS STREAMLINING PER D.RENAUD/D.SINISI

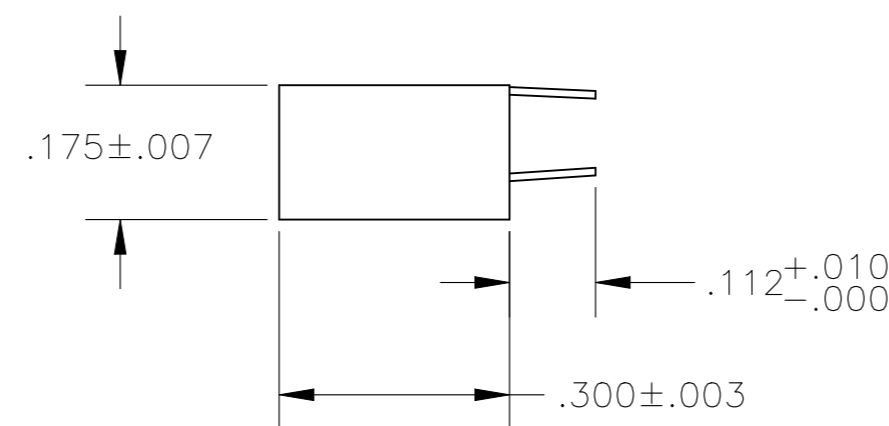
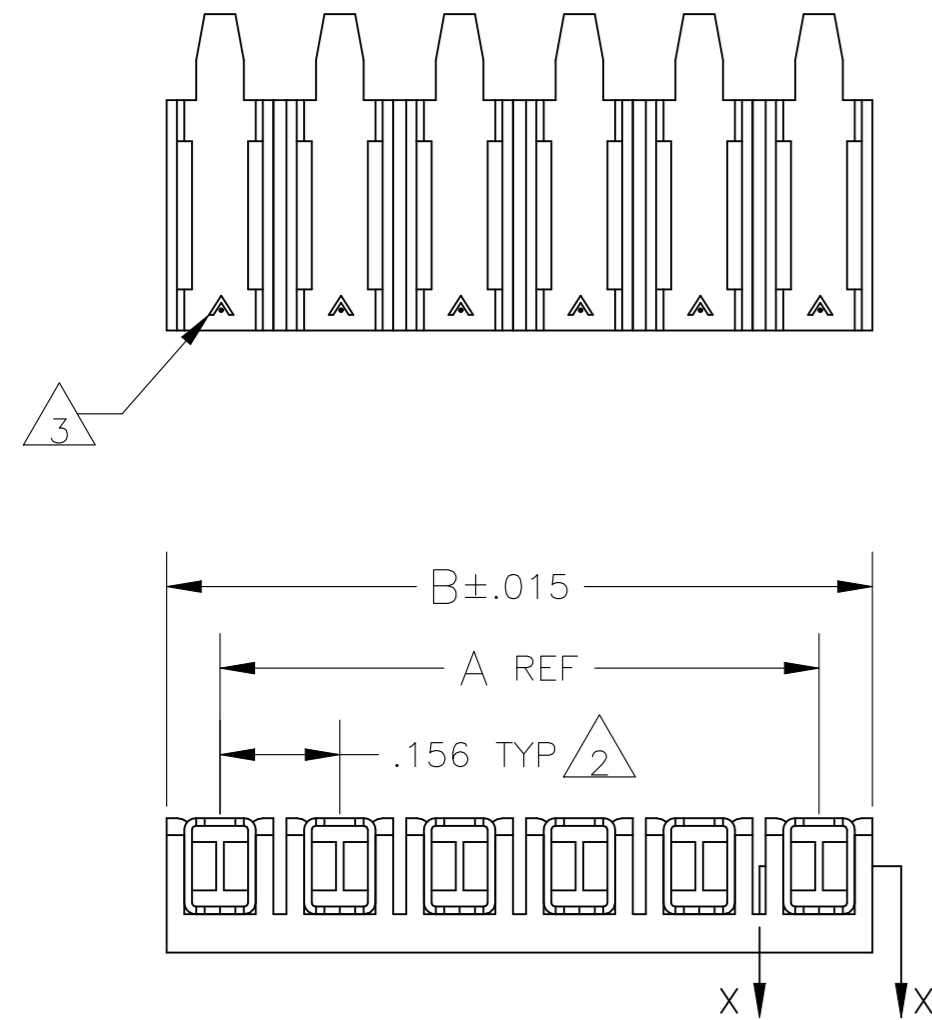
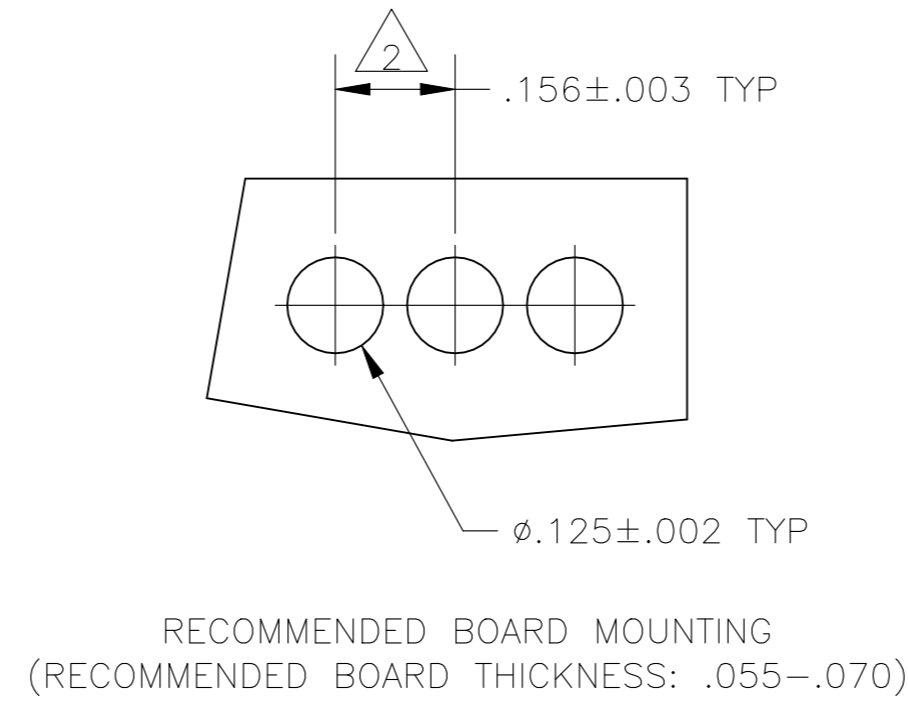
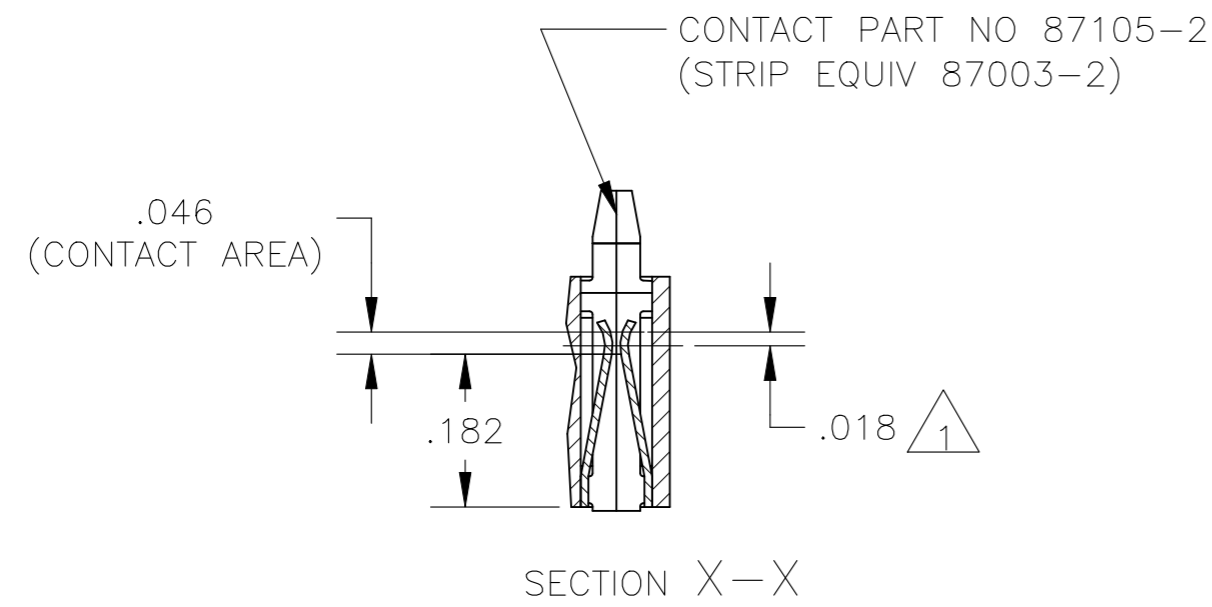

OBSOLETE 4	3.120	2.964	20	-2-87985-0
	2.964	2.808	19	-1-87985-9
	2.808	2.652	18	-1-87985-8
	2.652	2.496	17	-1-87985-7
	2.496	2.340	16	-1-87985-6
	2.340	2.184	15	1-87985-5
4 OBSOLETE	2.184	2.028	14	1-87985-4
	2.028	1.872	13	-1-87985-3
4 OBSOLETE	1.872	1.716	12	1-87985-2
	1.716	1.560	11	-1-87985-1
4 OBSOLETE	1.560	1.404	10	1-87985-0
	1.404	1.248	9	87985-9
	1.248	1.092	8	87985-8
	1.092	.936	7	-87985-7-
	.936	.780	6	87985-6
	.780	.624	5	87985-5
4 OBSOLETE	.624	.468	4	87985-4
	.468	.312	3	87985-3
	.312	.156	2	-87985-2-
	B	A	NO OF POSN	ASSEMBLY PART NUMBER

THIS DRAWING IS A CONTROLLED DOCUMENT.		DWN L D RINGLEY 17MAR86	TE Connectivity	
DIMENSIONS: INCHES		CHK P C DEJONG 18MAR86		
TOLERANCES UNLESS OTHERWISE SPECIFIED:		APVD P C DEJONG 18MAR86	NAME	
0 PLC ± - 1 PLC ± - 2 PLC ± - 3 PLC ± .005 4 PLC ± - ANGLES ± -		PRODUCT SPEC 108-25016	ASY, MOD I, BRD MNT REC, .156CL, STD PRESSURE, TYPE B	
MATERIAL: HOUSING-FLAME RETARDANT THERMOPLASTIC, COLOR-BLACK		APPLICATION SPEC 114-25004	SIZE A2	CAGE CODE 00779
CONTACTS: PHOS BRONZE		FINISH CONTACTS: .000079 MIN TIN.	DRAWING NO C=87985	RESTRICTED TO
		WEIGHT -	SCALE 4:1	SHEET 1 OF 1
		CUSTOMER DRAWING	REV L	