

P.C. BOARD MOUNTING DIMENSIONS
 (CONNECTOR SIDE)

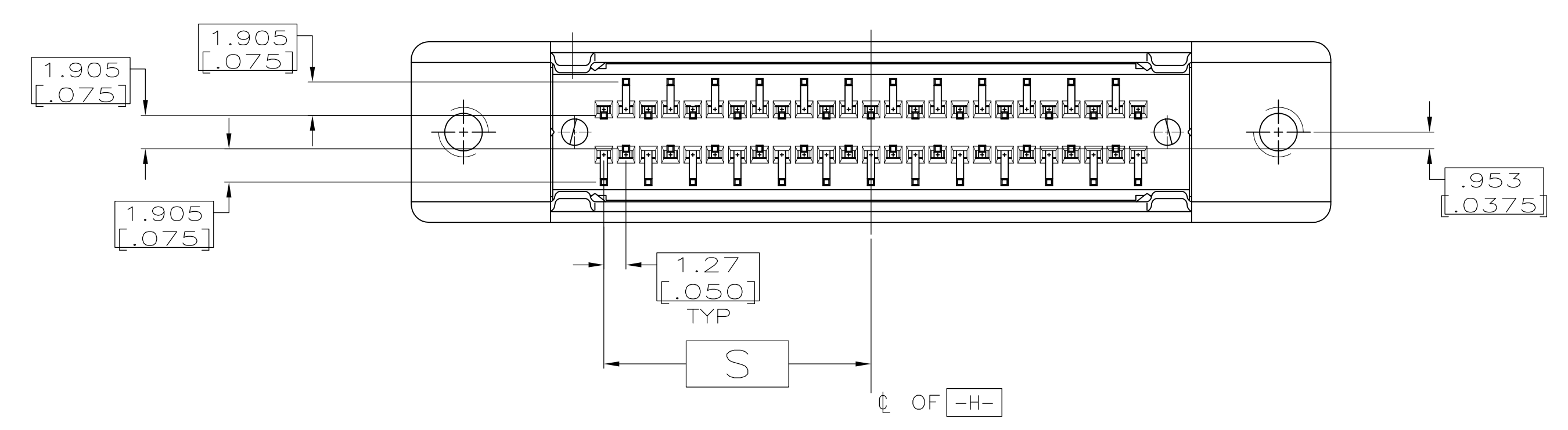
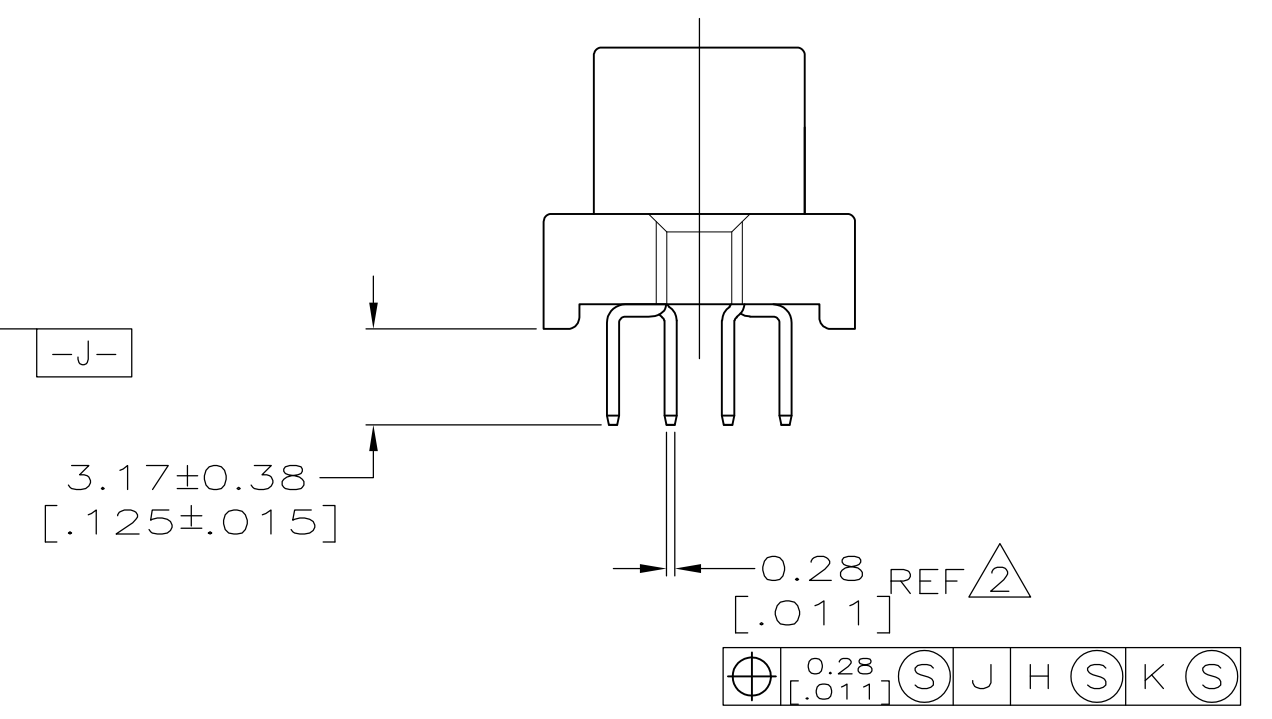
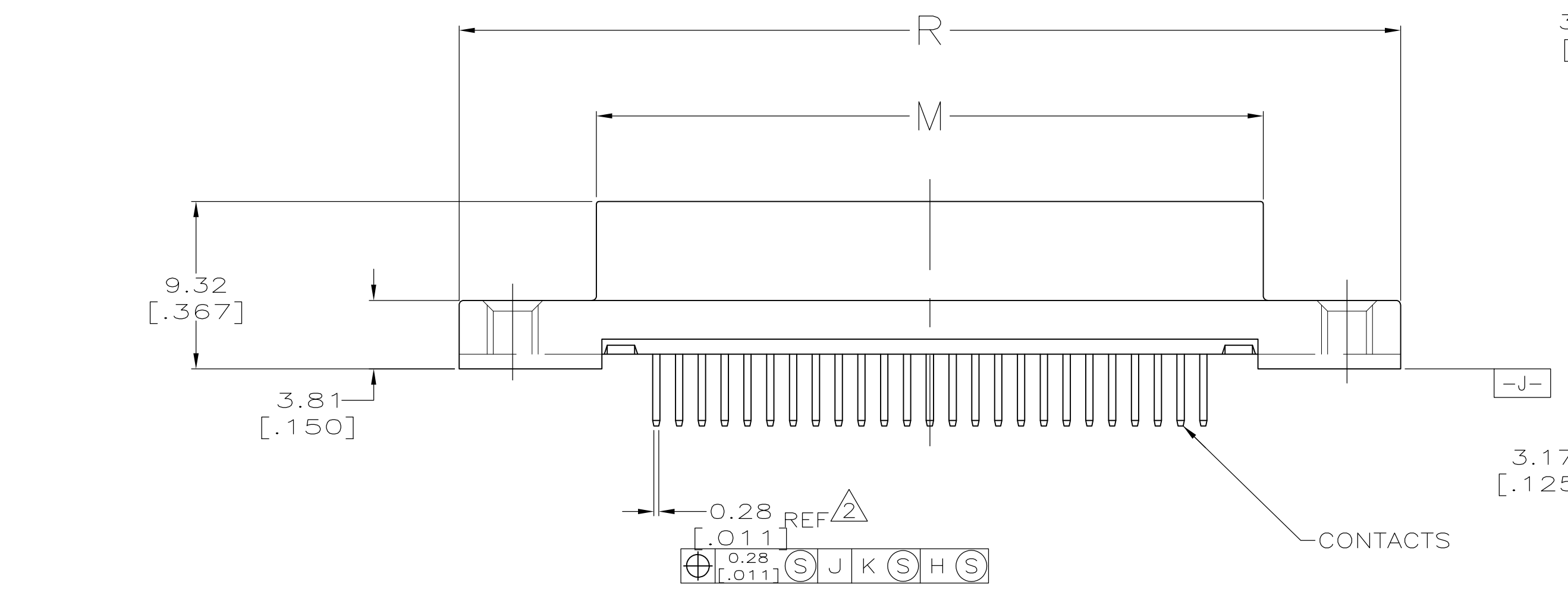

- △ FINISH
 CONTACTS: EITHER GOLD PLATED 0.76µm [.000030] MIN ON MATING END OR GOLD FLASH OVER PALLADIUM NICKEL, 0.76µm [.000030] MIN TOTAL ON MATING END. TIN-LEAD PLATED 3.05µm [.000120] MIN ON SOLDER LEAD, ALL OVER 1.27µm [.000050] MIN NICKEL UNDERPLATE.
 BACKET: NICKEL PLATED.
- △ POSITION TOLERANCE APPLIES AT TIP ONLY.
- △ MATERIAL
 CONTACTS: PHOSPHOR BRONZE.
 HOUSING: UL V-0 RATED POLYESTER LCP COLOR BLACK.
 BRACKET: ZINC.
- △ ACTUAL HOLE SIZE USED WILL DEPEND ON TRACE ROUTING REQUIREMENTS BETWEEN HOLES AND CONNECTOR PLACEMENT TECHNIQUE.

50 POSITION AS SHOWN

| | | | | | | | | |
|-----------|------------------|------------------|------------------|------------------|------------------|------------------|-------------|-------------|
| X | 31.11 [1.225] | 84.20 [3.315] | 62.23 [2.450] | 66.60 [2.622] | 68.94 [2.714] | 78.23 [3.080] | 100 | 749085-9 |
| Y | 15.24 [.600] | 52.45 [2.065] | 30.48 [1.200] | 34.85 [1.372] | 37.19 [1.464] | 46.48 [1.830] | 50 | 749085-5 |
| PWB BOARD | S | R | P | N | M | L | NO. OF POSN | PART NUMBER |

| | | | | |
|--|--|--|---|--|
| THIS DRAWING IS A CONTROLLED DOCUMENT. | | DWN: JACK ROOT 5-2-89 | Tyco Electronics Corporation Harrisburg, PA 17105-3608 | |
| DIMENSIONS: mm [INCHES] | | CHK: M. VISELLI 5-2-89 | NAME: R. WHITEMAN 5-3-89 | |
| TOLERANCES UNLESS OTHERWISE SPECIFIED: | | PRODUCT SPEC: PLUG ASSEMBLY, SHIELDED, VERTICAL, AMPLIMITE .050 Series | | |
| 0 PLC ± - | | APPLICATION SPEC: - | | |
| 1 PLC ± - | | SIZE: A1 | | |
| 2 PLC ± 0.38 [.015] | | CAGE CODE: 749085 | | |
| 3 PLC ± - | | DRAWING NO: 749085 | | |
| 4 PLC ± - | | RESTRICTED TO: - | | |
| ANGLES ± - | | CUSTOMER DRAWING | | |
| MATERIAL: 3 | | SCALE: 4:1 | | |
| FINISH: 1 | | SHEET: 1 OF 1 | | |
| | | REV: J | | |