

PIR Alarm Controller

Features

- Low standby current
- 2 stage op-amp for filtering
- On-chip oscillator
- On-chip voltage regulator
- 4 different operation modes selected by SEL1 & SEL2
- Low battery detector
- Built-in noise rejection circuit
- LED output indicating warm-up period, low battery and PIR trigger signal
- 2 outputs to drive external devices such as speech ICs, high pitch piezo buzzer or door bell ICs
- Lead free DIP-16 and SOIC-16 package
- Door chime applications with external door bell ICs

Description

PT8A263 is a fully integrated mixed-signal CMOS LSI chip designed for the low cost applications of PIR (passive Infrared) alarm control system. The analog front-end is based on PTI's proven PIR controller IC (PT8A261). The multipurpose alarm IC can be widely used in a variety of applications ranging from household security, portable alarm to toys.

PT8A263 is also equipped with op-amps for filtering, a comparator, timer, low battery detector, control circuit, voltage regulator and oscillator.

Applications

- Low cost security system sensor components
- Motion sensor to drive low cost speech chip for alarm alert
- Motion detect alarm with high pitch buzzer alert

Block Diagram

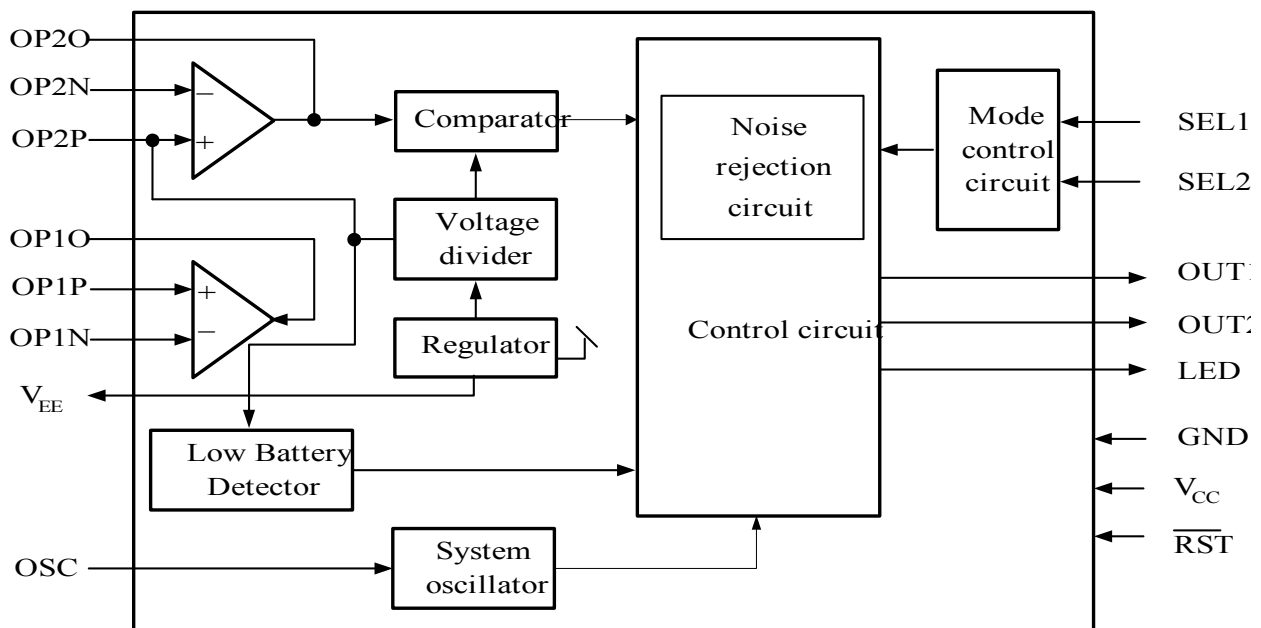

Pin Configuration

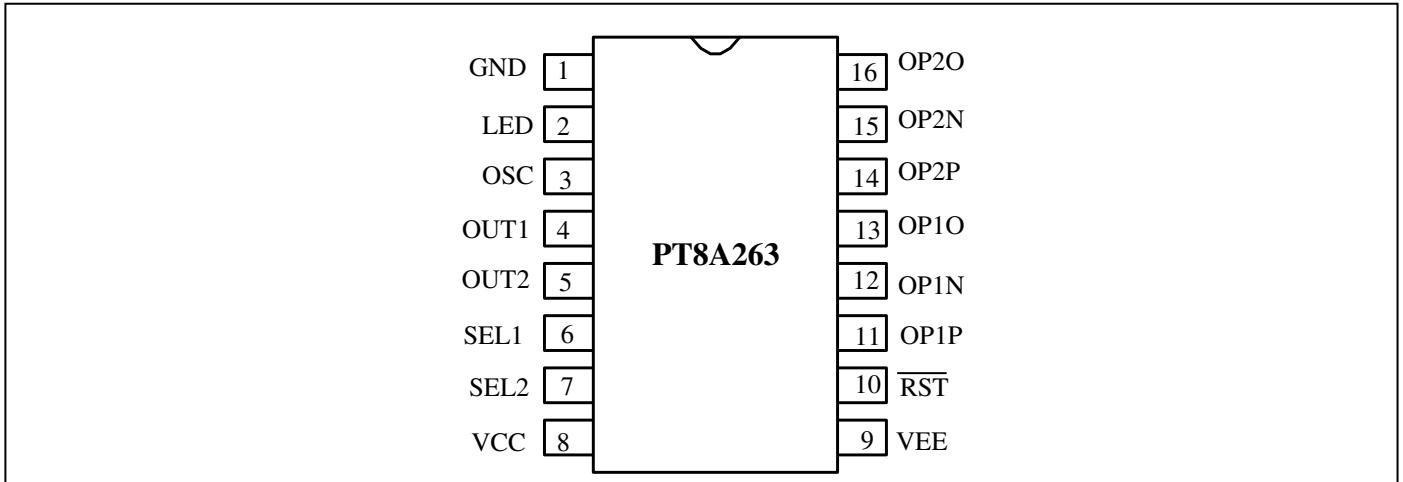

Pin Description

Name	Pin No.	Type	Description
GND	1	Ground	Ground
LED	2	O	LED output: indicates PIR trigger signal. It is an active high signal with 125Hz pulse in normal mode.
OSC	3	I	Input of oscillator: external resistor or capacitor changeable, resistor pull up, capacitor pull down, 16kHz for normal application
OUT1, OUT2	4, 5	O	Outputs to drive external devices
SEL1, SEL2	6, 7	O	Operating mode selection
VCC	8	Power	Power supply
VEE	9	O	Internal voltage regulator output: 3.6V with respect to ground. Connected to the drain of PIR sensor
RST	10	I	Chip reset input: active low, kept floating or connected an RC network
OP1P	11	I	Non-inverted input of first operational amplifier: connected directly to source of PIR sensor
OP1N	12	I	Inverted input of first operational amplifier
OP1O	13	O	Output of first operational amplifier
OP2P	14	I	Non-inverted input of second operational amplifier, 1.8V internally, 2.2uF capacitor pull down
OP3N	15	I	Inverted input of second operational amplifier
OP2O	16	O	Output of second operational amplifier

Pad Location

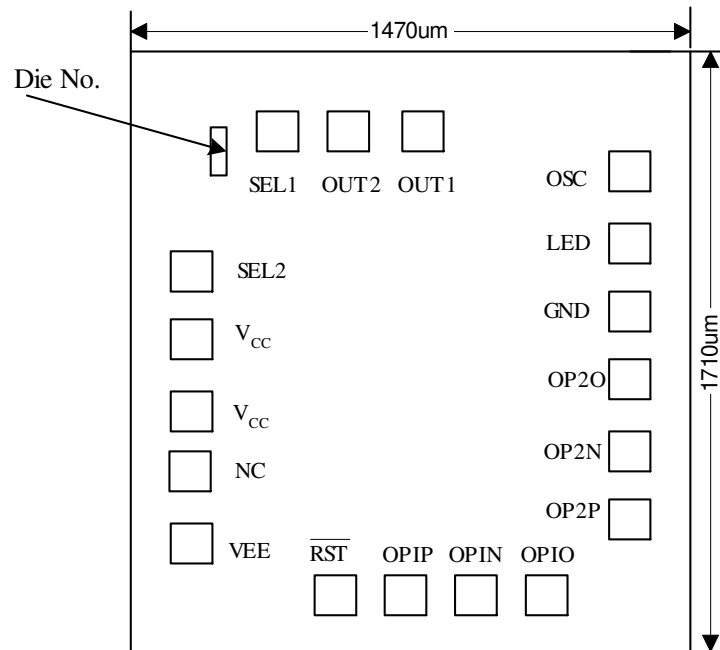

Pad Coordinate					
Pad Name	X Coordinate	Y Coordinate	Pad Name	X Coordinate	Y Coordinate
GND	570	65.4	NC	570	-268.6
LED	570	-101.6	V _{EE}	-570	232.4
OSC	570	399.4	$\overline{\text{RST}}$	303.9	-687.2
OUT1	570	232.4	OP1P	-44.8	689.2
OUT2	-378.8	689.2	OP1N	-211.8	689.2
SEL1	-30.1	-687.2	OP1O	-570	-435.6
SEL2	570	-435.6	OP2P	-570	-268.6
V _{CC}	-197.1	-687.2	OP2N	-570	-101.6
V _{CC}	136.9	-687.2	OP2O	-570	65.4

Note: Substrate is connected to GND

Maximum Ratings

Storage Temperature	-40°C to +125°C
Ambient Temperature with Power applied	-20°C to +85°C
Supply Voltage to Ground Potential (Inputs & V _{CC} Only)	-0.5V to +6.0V
Supply Voltage to Ground Potential (Outputs & D/O Only)	-0.5V to +6.0V
DC Input Voltage	-0.5V to +6.0V
DC Output Current	20mA
Power Dissipation	500mW

Note:

Stresses greater than those listed under MAXIMUM RATINGS may cause permanent damage to the device. This is a stress rating only and functional operation of the device at these or any other conditions above those indicated in the operational sections of this specification is not implied. Exposure to absolute maximum rating conditions for extended periods may affect reliability.

Recommended operation conditions

Sym	Parameter	Min	Typ	Max	Unit
V _{CC}	Supply Voltage	4.75	5.0	6.0	V
V _{IH}	Input HIGH Voltage	0.8 V _{CC}	-	-	V
V _{IL}	Input LOW Voltage	-	-	0.2V _{CC}	V
f _{SYS}	System Oscillator Frequency	12.8	16	19.2	kHz
T _A	Operating temperature	-25	-	70	°C

DC Electrical Characteristics

Sym	Description	Test Conditions	Min	Typ	Max	Units
I _{IH}	Input high level current - SEL1 and SEL2	V _{IH} = 4.5V	-1	-	1	µA
	Input high level current - RST		-1	-	-10	µA
	Input high level current - OSC		400	-	550	µA
I _{IL}	Input low level current - SEL1, SEL2, OSC	V _{IL} = 0.5V	-1	-	1	µA
	Input low level current - OSC		-10	-	-20	µA
I _{OH}	Output Source Current (OUT1, OUT2)	V _{OH} = 4.5V	-6	-12	-	mA
I _{OL}	Output Sink Current (OUT1, OUT2)	V _{OL} = 0.5V	15	55	-	mA
V _{TH}	OSCS Transfer High Voltage	-	2.0	2.3	2.8	V
V _{TL}	OSCS Transfer Low Voltage	-	1.0	1.2	1.6	V

Note: These specifications apply for V_{CC} = 5.0V and -25°C ≤ T_A ≤ 70°C, unless otherwise specified.

AC Electrical Characteristics

Voltage Regulator

Sym	Description	Test Conditions	Min	Typ	Max	Units
V _{EE}	Output Voltage	No load	3.4	3.6	3.8	V
OP2P	Noninverting input of OP2	No load	1.6	1.8	2.0	V
ΔV _O	Line Regulation	4.5V ≤ V _{CC} ≤ 5.5V, I _L = 1mA C _{filter} = 4.7µF (between V _{EE} pin and GND pin)	-	1.0	50	mV
ΔV _{LDR}	Load Regulation	V _{CC} = 5V, 0.5mA ≤ I _L ≤ 2mA C _{filter} = 4.7µF (between V _{EE} pin and GND pin)	-	10	100	mV
I _L	Maximum Current	V _{CC} = 5V	-4	-	-	mA

Operational Amplifier and Window Comparator

Sym	Description	Test Conditions	Min	Typ	Max	Units
UGBW	Unit Gain B and width	-	10	-	-	kHz
V _{TH}	Windows Comparator Threshold	V _{CC} = 5V	1.9	2.05	2.2	V
V _{TL}		V _{CC} = 5V	1.4	1.55	1.7	V

Oscillator

Sym	Description	Test Conditions	Min	Typ	Max	Units
f_{OSCS}	Oscillator Frequency	$V_{CC}=5V, R_S=560k\Omega, C_S=200p$	12.8	16	19.2	kHz
T_{OSCS}	Oscillator period	-	52	62.5	78	μs

Power Dissipation

Sym	Description	Test Conditions	Min	Typ	Max	Units
I_{CC}	Power Supply Current	$V_{CC}=5V, f_{OSCS}=16kHz, R_S=560k\Omega, C_S=200p$, Input Pins=GND, all output pins floating	-	80	100	μA
I_{CCQ}	Quiescent Supply Current	$V_{CC}=5V$, Input Pins=GND, all output pins floating	-	70	-	μA

Low Battery Detector

Sym	Description	Test Conditions	Min	Typ	Max	Units
V_{LBTH}	Low Battery Detector Threshold Voltage	$V_{CC}=5V$	3.50	3.80	4.01	V

Functional Description

The PIR sensor detects infrared power variations induced by the motion of a human body and converts it to voltage variations. This input voltage is fed into PT8A263 for signal processing. Bandpass filtering is first accomplished by a 2-stage op-amp, followed by the peak and valley voltages comparisons. If the input signal is larger than the specified peak voltage or smaller than the specified valley voltage for a certain period of time, this PIR trigger signal will be produced to the internal noise rejection circuit in which a valid trigger is qualified based on some criteria. The output signals will then be generated to drive external devices according to different mode of operations.

- **V_{EE}**
V_{EE} supplies power to the analog front-end circuit with a stabilized voltage that is 3.6V with respect to GND normally.
- **OSC**
OSC is an I/O pin of internal oscillator. System frequency of 16KHz can be generated when connected to an external RC.

- **Low Battery Detection**
Internal low Battery Detector indicates voltage value of V_{CC} less than a contain value which is about 3.8V. A Low Battery alarm indication can be given at LED pin when the division voltage is less than V_{EE}/2. At the same time the system will be halt. Most of the internal circuits are hung up except oscillator and LED indication circuit.
- **$\overline{\text{RST}}$**
RST is used to reset the chip. It is internal pull-high and active low. The use of CRST can extend the power-on initial time. If the $\overline{\text{RST}}$ pin is an open circuit (without CRST), the initial time is the default (40 seconds).
- **Power On Initial**
The PIR signal amplifier requires a warm up period after power-on. The input should be disabled during this period.
- **Operational Mode**
The operation modes of PT8A263 are shown in the following table.

Mode of Operation/2

SEL1	SEL2	Functions
1	1	Normal Alarm: OUT1 = low (active) for 5 seconds after the first trigger. OUT2 goes low for 5 seconds after the 2nd trigger. LED does not latch trigger status. OUT2 (low active) will not trigger if there is no PIR signal 12 seconds after the first trigger.
0	1	Normal Alarm with Delay: OUT1 goes low after first triggered, if the second trigger signal comes after 15 seconds, OUT2 keep high, if the second trigger signal comes after 12 seconds but less than 15 seconds, OUT2 will goes low for 5 seconds. LED is latched on until power down or reset the chip.
1	0	Siren Alarm: Complimentary drive high pitch piezo buzzer. Center frequency = 1kHz (options for 500Hz and 2kHz). 2 stages of alarm: First trigger: Output is 1/4 sec on, 4 sec off. If no 2nd trigger within 12 sec, all outputs are reset, no sound. 2nd trigger: Output is 1/4 sec on, 2 sec off for 30 sec. After 30 sec, output = 1 sec on, 1/2 sec off, continue for 5 minutes. After that, the chip enters stop mode. LED is latched on after 2nd trigger, until power down or chip reset.
0	0	Door Chime mode: Once trigger occurs, OUT1 is active (high) for 1 sec, OUT2 is active (high) for another 1 sec after OUT1 is asserted. LED has no latch function.

Timing Diagram

PIR Signal Trigger and Output Signals for Door Chime Mode

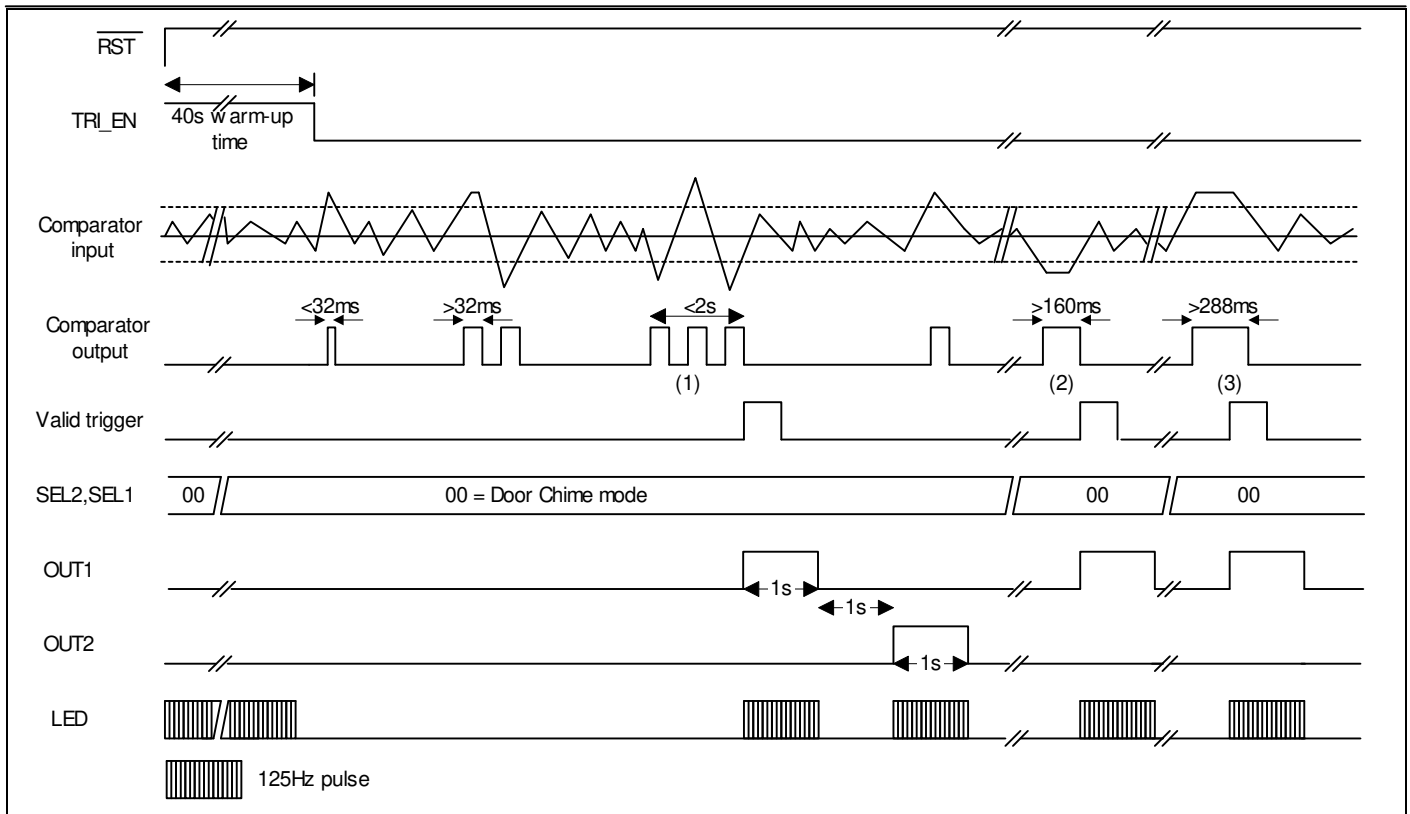

Notes:

The PIR trigger signal is qualified to be a valid PIR trigger signal if it conforms to one of the following criteria :

1. More than 3 triggers (each > 32ms) detected within 2s,
2. Two triggers detected within 2s (1 trigger > 160ms and another > 32ms),
3. One trigger (> 288ms) detected.

Output Signals for Normal Alarm Mode

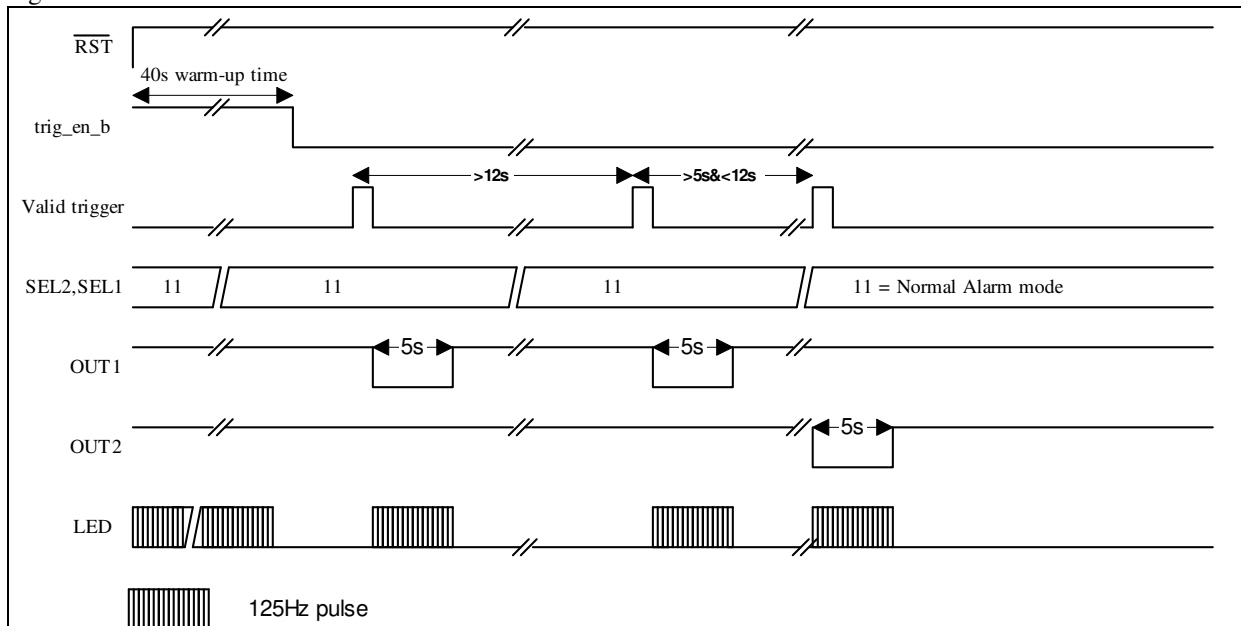

Output Signals for Normal Alarm with Delay Mode

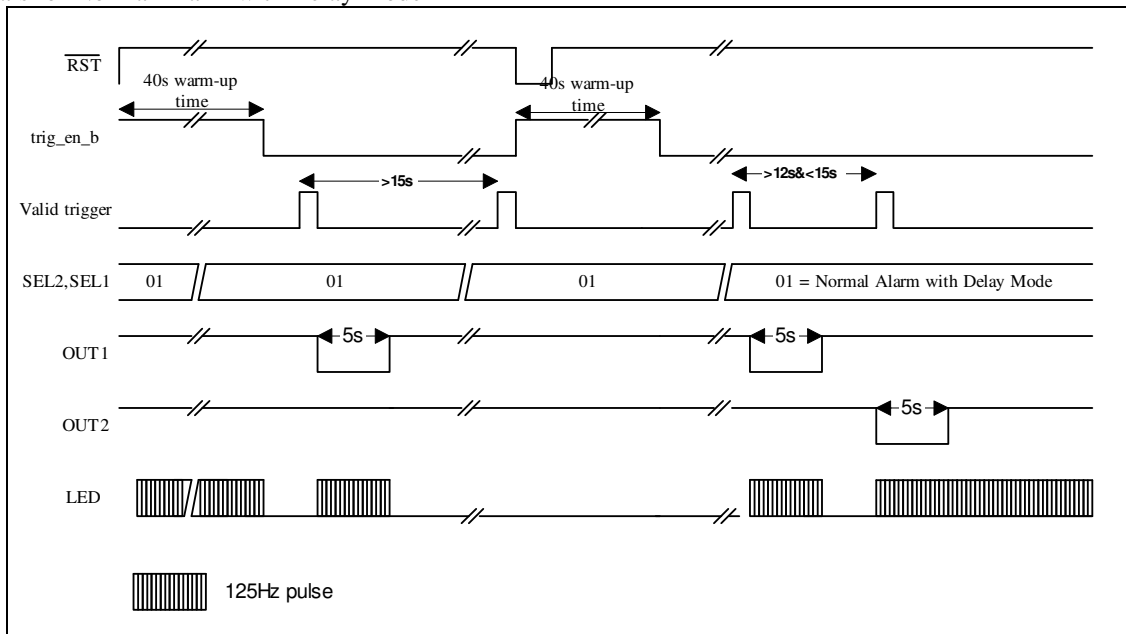

Output Signals for Siren Alarm Mode

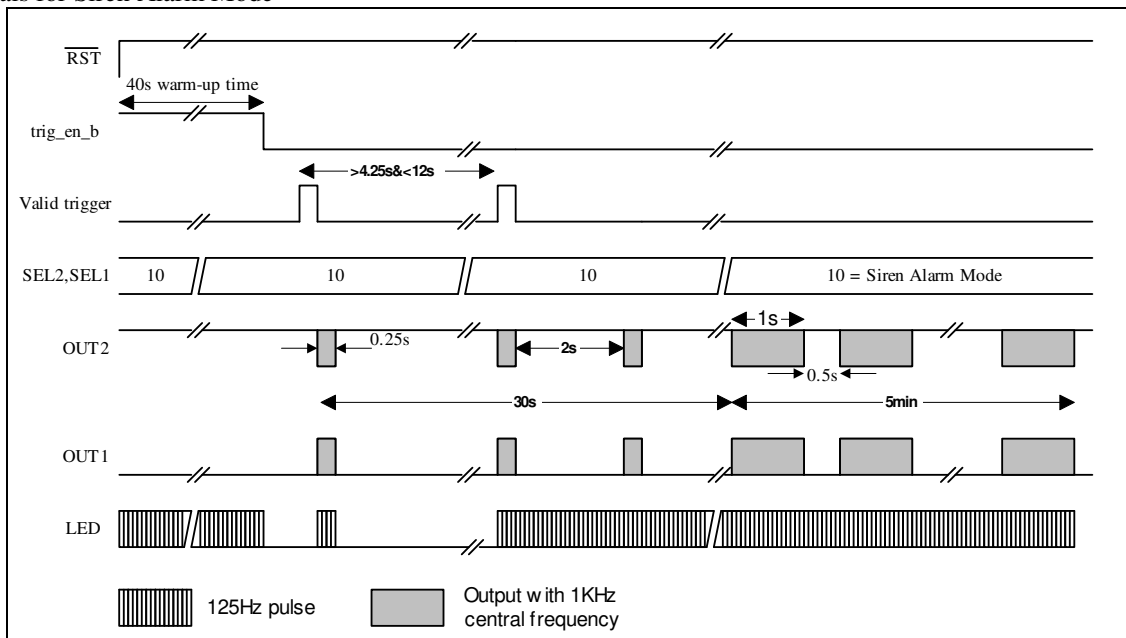

Low Battery Detection Operation

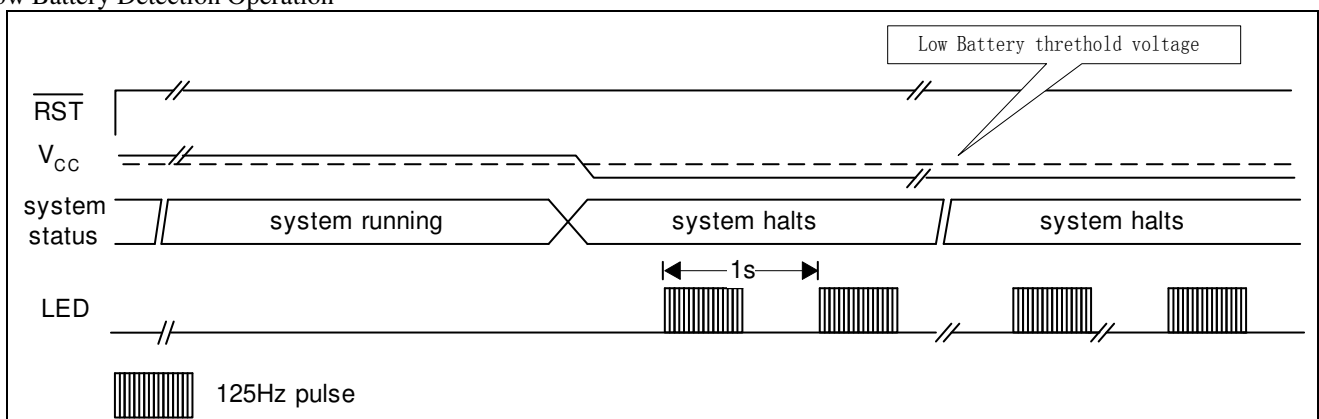

Application Circuit
Siren Alarm Mode

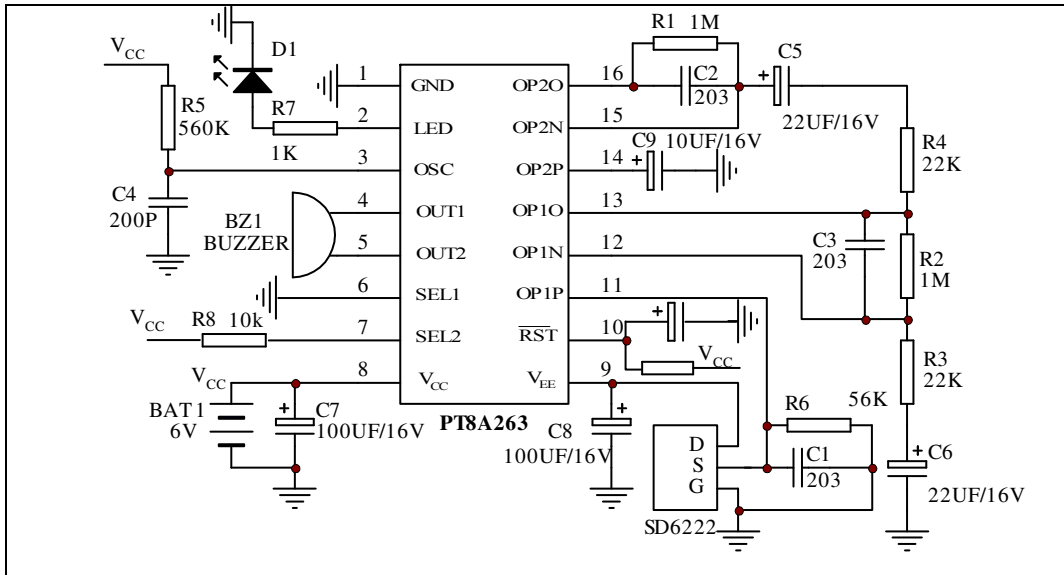

Door Chime Mode

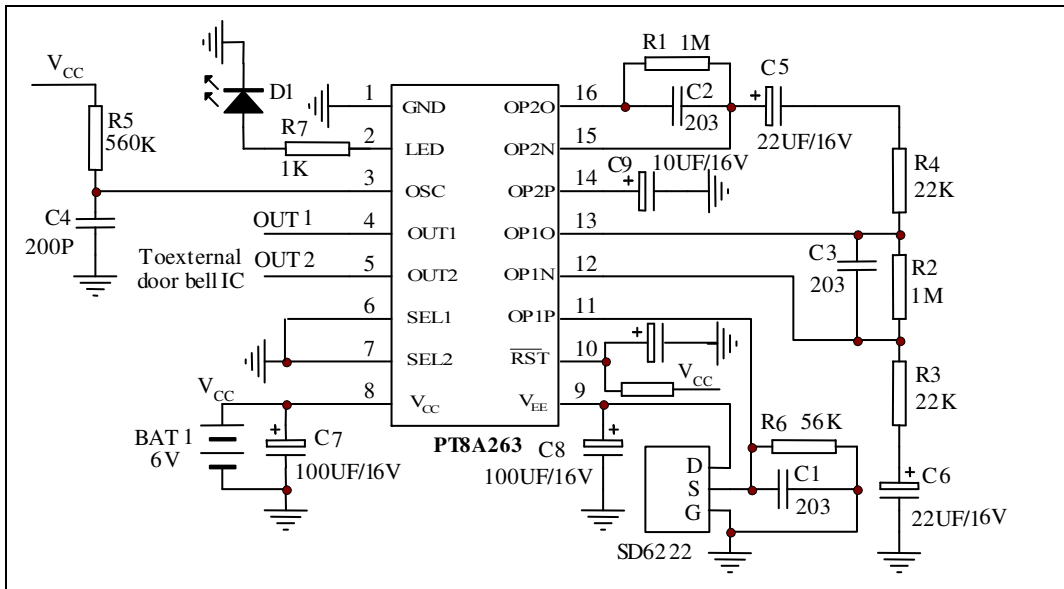

Mechanical Information

PE (Lead free DIP-16)

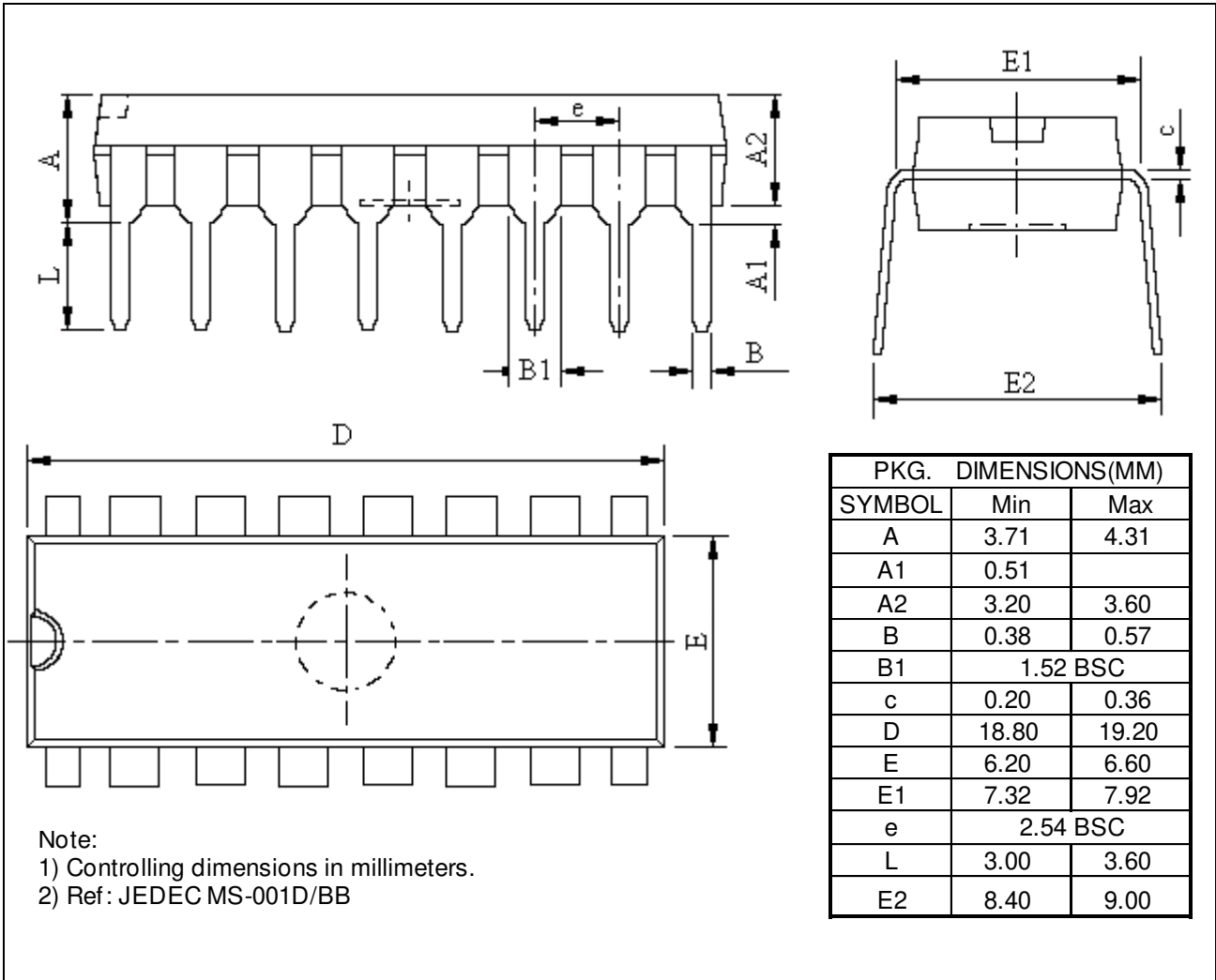

WE (Lead free SOIC-16)

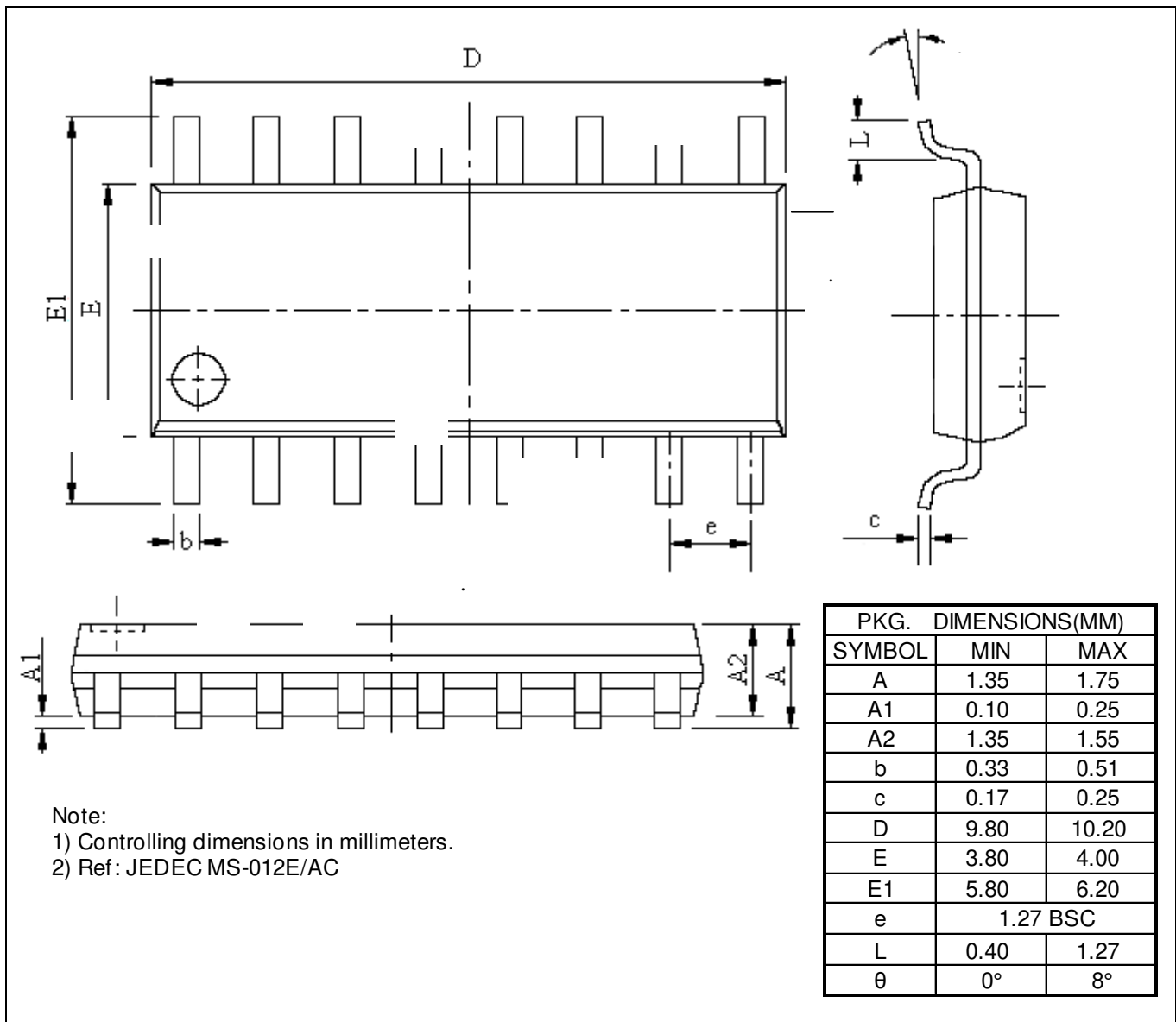

Ordering Information

Ordering No.	Package Code	Package
PT8A263PE	P	Lead free 16-pin DIP
PT8A263WE	W	Lead free 16-pin SOIC
PT8A263DE*	DE	Die form

Note:

- E = Pb-free
- Adding X Suffix= Tape/Reel
- *Contact Pericom for availability.

Pericom Semiconductor Corporation • 1-800-435-2336 • www.pericom.com

Pericom reserves the right to make changes to its products or specifications at any time, without notice, in order to improve design or performance and to supply the best possible product. Pericom does not assume any responsibility for use of any circuitry described other than the circuitry embodied in Pericom product. The company makes no representations that circuitry described herein is free from patent infringement or other rights, of Pericom.