

STK5F4U3C2D-E

Intelligent Power Module (IPM) 600 V, 30 A



ON Semiconductor®

www.onsemi.com

Overview

This “Inverter Power IPM” is highly integrated device containing all High Voltage (HV) control from HV-DC to 3-phase outputs in a single DIP module (Dual-In line Package). Output stage uses IGBT / FRD technology and implements Under Voltage Protection (UVP) and Over Current Protection (OCP) with a Fault Detection output flag. Internal Boost diodes are provided for high side gate boost drive.

Function

- Single control power supply due to Internal bootstrap circuit for high side pre-driver circuit
- All control inputs and status outputs are at low voltage levels directly compatible with microcontrollers.
- A single power supply drive is enabled through the use of bootstrap circuits for upper power supplies
- Built-in dead-time for shoot-thru protection
- Having open emitter output for low side IGBTs ; individual shunt resistor per phase for OCP
- Externally accessible embedded thermistor for substrate temperature measurement
- Shutdown function ‘ITRIP’ to disable all operations of the 6 phase output stage by external input

Certification

- UL1557 (File number : E339285)

Specifications

Absolute Maximum Ratings at Tc = 25°C

Parameter	Symbol	Remarks	Ratings	Unit
Supply voltage	V _{CC}	P to NU, NV, NW, surge < 500 V *1	450	V
Collector-emitter voltage	V _{CE}	P to U, V, W, U to NU, V to NV, or W to NW	600	V
Output current	I _o	P, NU, NV, NW, U, V, W terminal current	±30	A
		P, NU, NV, NW, U, V, W terminal current, Tc = 100°C	±15	
Output peak current	I _{op}	P, NU, NV, NW, U, V, W terminal current, PW = 1 ms	±45	A
Pre-driver supply voltage	VD1, 2, 3, 4	VB1 to VS1, VB2 to VS2, VB3 to VS3, V _{DD} to V _{SS} *2	20	V
Input signal voltage	V _{IN}	HIN1, 2, 3, LIN1, 2, 3, terminal	-0.3 to V _{DD}	V
FAULT terminal voltage	V _{FAULT}	FAULT terminal.	-0.3 to V _{DD}	V
Maximum loss	P _d	IGBT per channel	56.8	W
Junction temperature	T _j	IGBT, FRD	150	°C
Storage temperature	T _{stg}		-40 to +125	°C
Operating temperature	T _c	IPM case	-20 to +100	°C
Tightening torque	MT	A screw part at use M4 type screw *3	1.17	Nm
Withstand Voltage	V _{is}	50 Hz sine wave AC 1 minute *4	2000	VRMS

Reference voltage is “V_{SS}” terminal voltage unless otherwise specified.

*1 : Surge voltage developed by the switching operation due to the wiring inductance between the P and N terminals.

*2 : Terminal voltage : VD1 = VB1 to VS1, VD2 = VB2 to VS2, VD3 = VB3 to VS3, VD4 = V_{DD} to V_{SS}.

*3 : Flatness of the heat-sink should be 0.25 mm and below.

*4 : Test conditions : AC 2500 V, 1 s.

Stresses exceeding those listed in the Maximum Ratings table may damage the device. If any of these limits are exceeded, device functionality should not be assumed, damage may occur and reliability may be affected.

ORDERING INFORMATION

See detailed ordering and shipping information on page 14 of this data sheet.

STK5F4U3C2D-E

Electrical Characteristics at $T_c = 25^\circ\text{C}$, $V_{D1}, V_{D2}, V_{D3}, V_{D4} = 15\text{ V}$

Parameter	Symbol	Conditions	Test Circuit	Ratings			Unit
				Min.	Typ.	Max.	
Power output section							
Collector-to-emitter cut-off current	I_{CE}	$V_{CE} = 600\text{ V}$	Fig.1	-	-	1.0	mA
Boot-strap diode reverse current	$I_{R(BD)}$	$V_{R(BD)} = 600\text{ V}$	-	-	-	0.5	mA
Collector-to-emitter saturation voltage	$V_{CE(sat)}$	$I_c = 30\text{ A}, T_j = 25^\circ\text{C}$	Fig.2	-	1.7	2.5	V
		$I_c = 15\text{ A}, T_j = 100^\circ\text{C}$		-	1.4	-	
Diode forward voltage	V_F	$I_F = 30\text{ A}, T_j = 25^\circ\text{C}$	Fig.3	-	1.8	2.7	V
		$I_F = 15\text{ A}, T_j = 100^\circ\text{C}$		-	1.5	-	
Junction to case thermal resistance	$\theta_{j-c(T)}$	IGBT	-	-	1.8	-	$^\circ\text{C/W}$
	$\theta_{j-c(D)}$	FWD	-	-	2.3	-	$^\circ\text{C/W}$
Control (Pre-driver) section							
Pre-drive power supply consumption current	I_D	$V_{D1}, 2, 3 = 15\text{ V}$	Fig.4	-	0.05	0.4	mA
		$V_{D4} = 15\text{ V}$		-	1.0	4.0	
High level input voltage	$V_{in H}$	$HIN1, HIN2, HIN3,$	-	2.5	-	-	V
Low level input voltage	$V_{in L}$	$LIN1, LIN2, LIN3$	-	-	-	0.8	V
Protection section							
ITRIP threshold voltage	V_{ITRIP}	$ITRIP(17)$ to $V_{SS}(19)$	Fig.5	0.44	0.49	0.54	V
Pre-drive low voltage protection	$UVLO$		-	10	-	12	V
FAULT terminal input electric current	I_{OSD}	$V_{FAULT} = 0.1\text{ V}$	-	-	1.5	-	mA
FAULT clearance delay time	$FLTCLR$	From time fault condition clear	-	1.0	-	3.0	ms
Thermistor for substrate temperature monitor	R_t	Resistance between the TH1 and TH2 terminals	-	90	-	110	k Ω
Switching character							
Switching time	t_{ON}	$I_o = 30\text{ A}$, Inductive load	Fig.6	-	0.6	1.5	μs
	t_{OFF}			-	1.2	2.2	μs
Turn-on switching loss	E_{on}	$I_o = 30\text{ A}, V_{CC} = 300\text{ V}, V_D = 15\text{ V}, L = 680\text{ }\mu\text{H}$	Fig.6	-	710	-	μJ
Turn-off switching loss	E_{off}			-	570	-	μJ
Total switching loss	E_{tot}			-	1280	-	μJ
Turn-on switching loss	E_{on}	$I_o = 15\text{ A}, V_{CC} = 300\text{ V}, V_D = 15\text{ V}, L = 680\text{ }\mu\text{H}, T_c = 100^\circ\text{C}$	Fig.6	-	360	-	μJ
Turn-off switching loss	E_{off}			-	460	-	μJ
Total switching loss	E_{tot}			-	820	-	μJ
Diode reverse recovery energy	E_{rec}	$I_o = 15\text{ A}, V_{CC} = 300\text{ V}, V_D = 15\text{ V}, L = 680\text{ }\mu\text{H}, T_c = 100^\circ\text{C}$	Fig.6	-	16	-	μJ
Diode reverse recovery time	T_{rr}			-	50	-	ns

Reference Voltage is " V_{SS} " terminal voltage unless otherwise specified.

Product parametric performance is indicated in the Electrical Characteristics for the listed test conditions, unless otherwise noted. Product performance may not be indicated by the Electrical Characteristics if operated under different conditions.

STK5F4U3C2D-E

Notes

- Input ON voltage indicates the threshold of input signal voltage to turn on output stage IGBT.
Input OFF voltage indicates the threshold of input signal voltage to turn off output stage IGBT.
At the time of output ON, set the input signal voltage $V_{inH}(MAX)$ to 15 V.
At the time of output OFF, set the input signal voltage 0 V to $V_{inH}(MIN)$.
*1 The hysteresis voltage is a reference value based on the designed value of built-in pre-driver.
- When the internal protection circuit operates, a FAULT signal is turned ON (When the FAULT terminal is low level, FAULT signal is ON state : output form is open DRAIN) but the FAULT signal does not latch. After protection operation ends, it returns automatically within about 1 ms to 3 ms and resumes operation beginning condition. So, after FAULT signal detection, set all input signal to OFF (Low) at once. However, the operation of pre-drive power supply low voltage protection (UVLO : with hysteresis about 0.2 V) is as follows.

Upper side :

The gate is turned off and will return to regular operation when recovering to the normal voltage, but the latch will continue till the input signal will turn 'low'

Lower side :

The gate is turned off and will automatically reset when recovering to normal voltage. It does not depend on input signal voltage.

- When assembling the IPM on the heat sink with M4 type screw, tightening torque range is 0.79 Nm to 1.17 Nm.
- The pre-drive low voltage protection is the feature to protect a device when the pre-driver supply voltage falls due to an operating malfunction.
- When use the over-current protection with external resistors, please set the current protection level to be equal or less than the rating of output peak current (I_{op}).

Pin Assignment

Pin No.	Name	Description	Pin No.	Name	Description
1	VB1	High side floating supply voltage 1	44	P	Positive bus input voltage
2	VS1	High side floating supply offset voltage	43	P	Positive bus input voltage
3	-	Without pin	42	P	Positive bus input voltage
4	VB2	High side floating supply voltage 2	41	-	Without pin
5	VS2	High side floating supply offset voltage	40	U	U+ phase output
6	-	Without pin	39	U	U+ phase output
7	VB3	High side floating supply voltage 3	38	U	U+ phase output
8	VS3	High side floating supply offset voltage	37	-	Without pin
9	-	Without pin	36	V	V+ phase output
10	HIN1	Logic input high side driver-Phase1	35	V	V+ phase output
11	HIN2	Logic input high side driver-Phase2	34	V	V+ phase output
12	HIN3	Logic input high side driver-Phase3	33	-	Without pin
13	LIN1	Logic input low side driver-Phase1	32	W	W+ phase output
14	LIN2	Logic input low side driver-Phase2	31	W	W+ phase output
15	LIN3	Logic input low side driver-Phase3	30	W	W+ phase output
16	FAULT	Fault out	29	-	Without pin
17	ITRIP	Over-current protection level setting pin	28	NU	U- phase output
18	VDD	+15 V main supply	27	NU	U- phase output
19	VSS1	Negative main supply	26	NV	V- phase output
20	VSS2	Negative main supply	25	NV	V- phase output
21	TH1	Thermistor out	24	NW	W- phase output
22	TH2	Thermistor out	23	NW	W- phase output

STK5F4U3C2D-E

Block Diagram

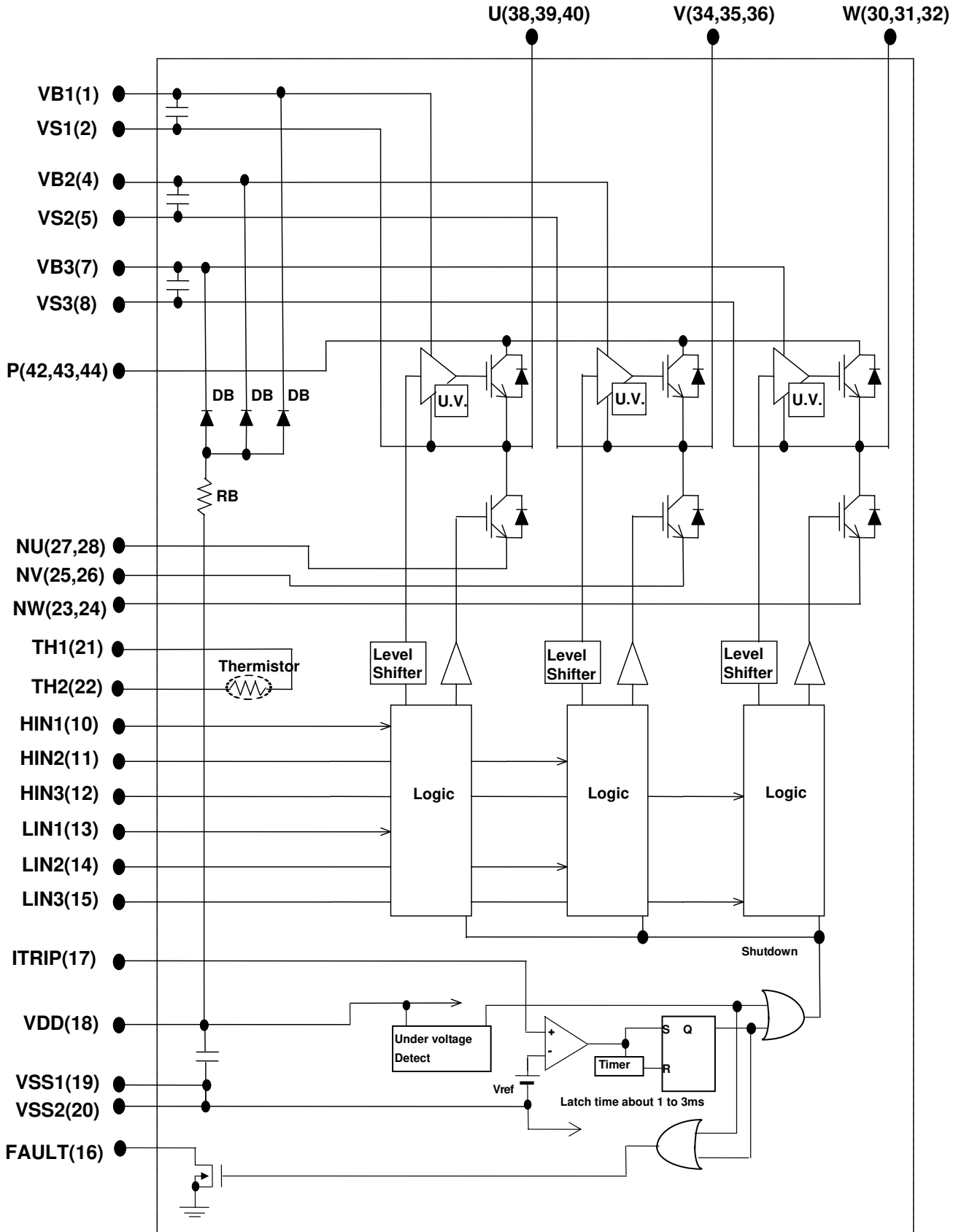

STK5F4U3C2D-E

Test Circuit

(The tested phase : U+ shows the upper side of the U phase and U- shows the lower side of the U phase)

■ ICE / IR(BD)

	U	V	W	NU	NV	NW
M	42	42	42	38	34	30
N	38	34	30	27	25	23

	U(BD)	V(BD)	W(BD)
M	1	4	7
N	19	19	19

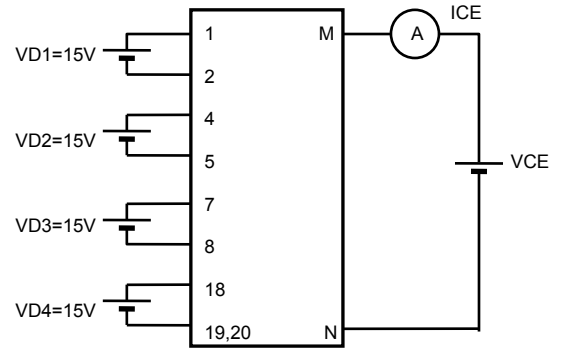

Fig.1

■ VCE(sat) (Test by pulse)

	U	V	W	NU	NV	NW
M	42	42	42	38	34	30
N	38	34	30	27	25	23
m	10	11	12	13	14	15

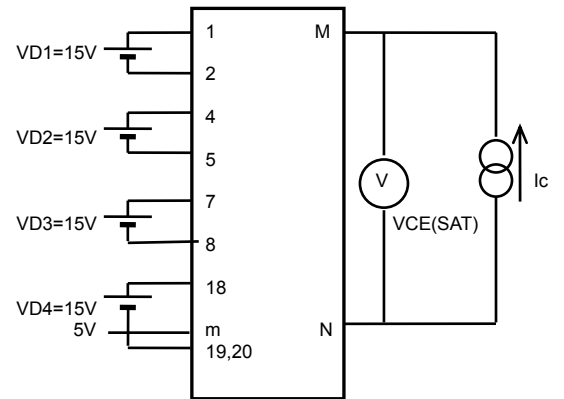

Fig.2

■ VF (Test by pulse)

	U	V	W	NU	NV	NW
M	42	42	42	38	34	30
N	38	34	30	27	25	23

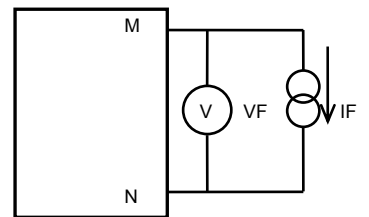

Fig.3

■ ID

	VD1	VD2	VD3	VD4
M	1	4	7	18
N	2	5	8	19

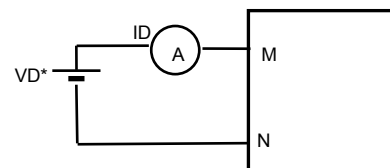

Fig.4

STK5F4U3C2D-E

■ ISD (The circuit is a representative example of the lower side U phase)

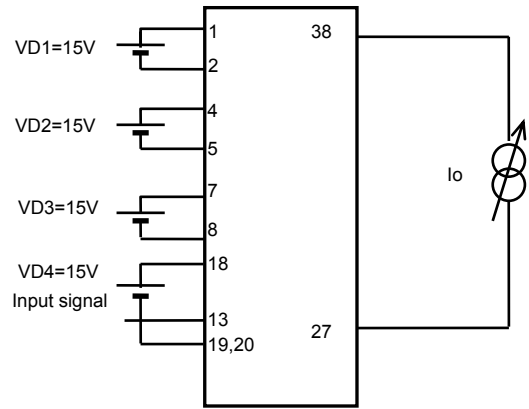
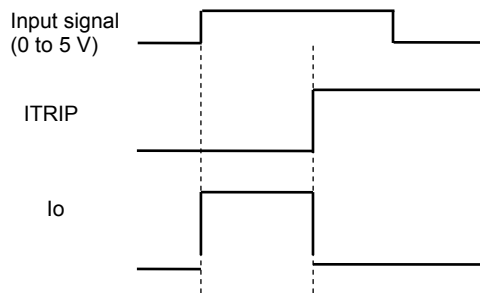

Fig.5

■ Switching time (The circuit is a representative example of the lower side U phase)

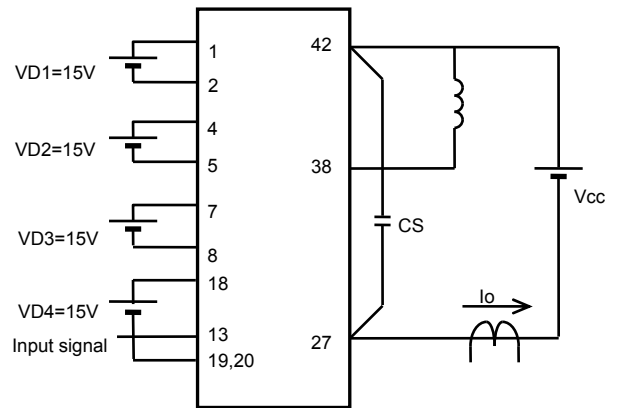
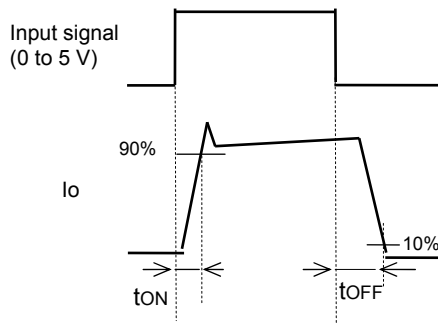

Fig.6

STK5F4U3C2D-E

Input / Output Timing Chart

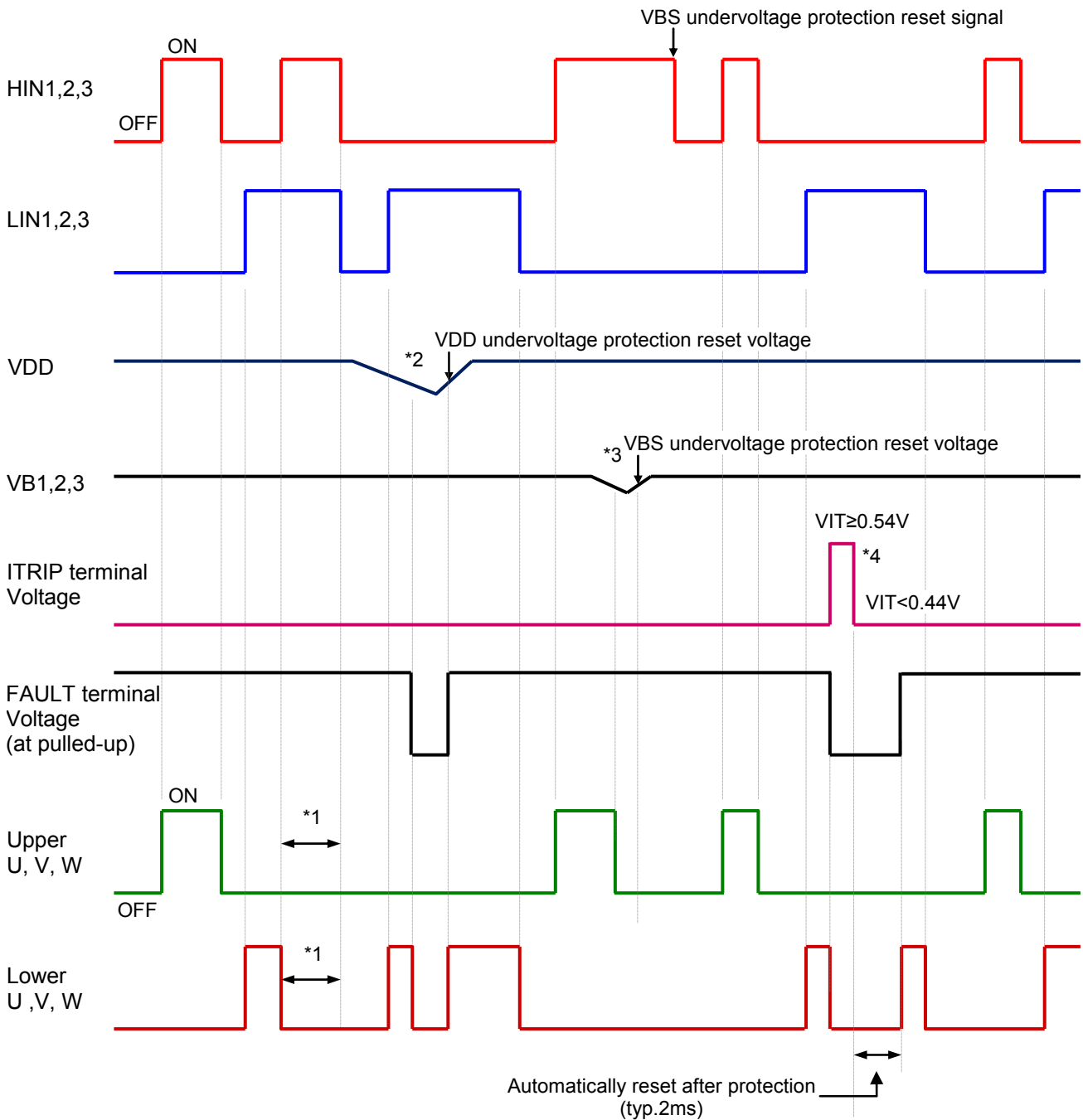

Fig.7

Notes

- *1 : Diagram shows the prevention of shoot-thru via control logic, however, more dead time must be added to account for switching delay externally.
- *2 : When V_{DD} decreases all gate output signals will go low and cut off all 6 IGBT outputs. When V_{DD} rises the operation will resume immediately.
- *3 : When the upper side voltage at VB1, VB2 and VB3 drops only the corresponding upper side output is turned off. The outputs return to normal operation immediately after the upper side gate voltage rises.
- *4 : When V_{ITRIP} exceeds threshold all IGBT's are turned off and normal operation resumes 2 ms (typ) after over current condition is removed.

STK5F4U3C2D-E

Logic level table

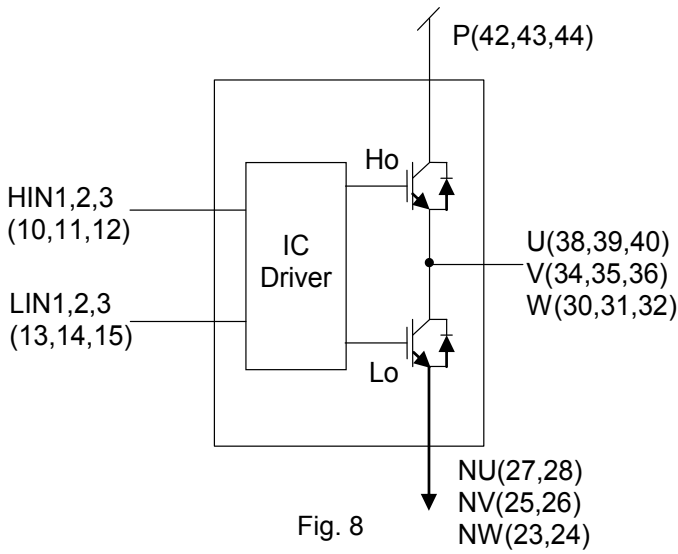

FAULT*	Itrip	HIN1,2,3	LIN1,2,3	U,V,W
1	0	1	0	Vbus
1	0	0	1	0
1	0	0	0	Off
1	0	1	1	Off
0	1	X	X	Off

* With pullup resistor

Application Circuit Example

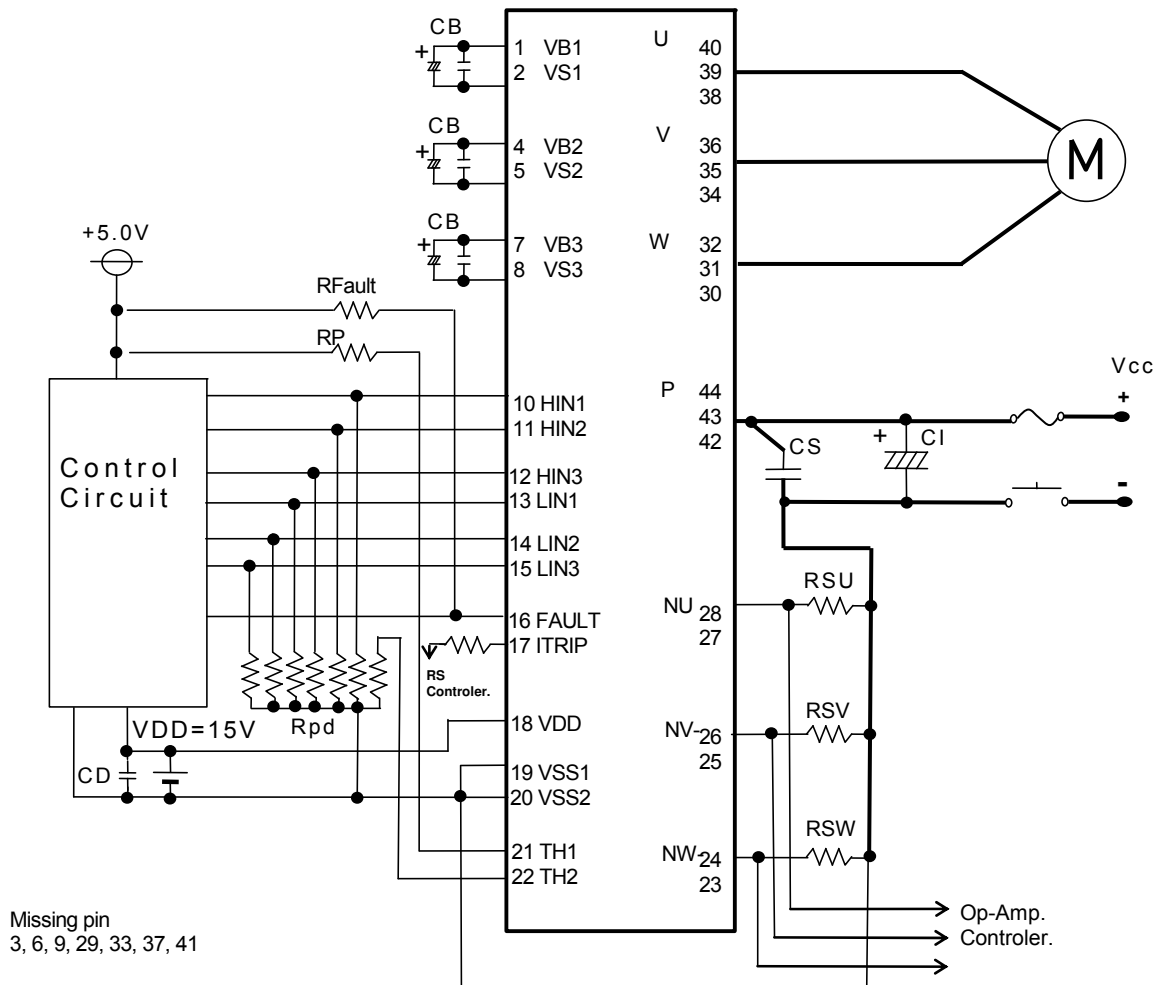

Fig. 9

STK5F4U3C2D-E

Recommended Operating Conditions at Tc = 25°C

Parameter	Symbol	Conditions	Ratings			Unit
			min	typ	max	
Supply voltage	V _{CC}	P to NU,NV,NW	0	280	450	V
Pre-driver supply voltage	VD1, 2, 3	VB1 to VS1, VB2 to VS2, VB3 to VS3	12.5	15	17.5	V
	VD4	V _{DD} to V _{SS} *1	13.5	15	16.5	
Input ON voltage	VIN(ON)	HIN1, HIN2, HIN3,	3.0	–	5.0	V
Input OFF voltage	VIN(OFF)	LIN1, LIN2, LIN3	0	–	0.3	
PWM frequency	f _{PWM}		1.0	–	20	kHz
Dead time	DT	Turn-off to turn-on (external)	2	–	–	μs
Allowable input pulse width	PWIN	ON and OFF	1	–	–	
Tightening torque	MT	'M4' Type Screw	0.79	–	1.17	Nm

*1 Pre-driver power supply (VD4 = 15 ±1.5 V) must have the capacity of I_o = 20 mA (DC), 0.5 A (Peak).

Functional operation above the stresses listed in the Recommended Operating Ranges is not implied. Extended exposure to stresses beyond the Recommended Operating Ranges limits may affect device reliability.

Usage Precautions

1. This IPM includes internal bootstrap diodes and resistors. By adding a bootstrap capacitor “CB”, a high side drive voltage is generated ; each phase requires an individual bootstrap capacitor. The recommended value of CB is in the range of 1 to 47 μF (±20%), however this value needs to be verified prior to production. If selecting the capacitance more than 47 μF (±20%), connect a resistor (about 40 Ω) in series between each 3-phase upper side power supply terminals (VB1, 2, 3) and each bootstrap capacitor. When not using the bootstrap circuit, each upper side pre-drive power supply requires n external independent power supply.
2. It is essential that wiring length between terminals in the snubber circuit be kept as short as possible to reduce the effect of surge voltages. Recommended value of “CS” is in the range of 0.1 to 10 μF.
3. “FAULT” (pin 16) is open DRAIN output terminal (Active Low). Pull up resistor is recommended more than 5.6 kΩ.
4. Inside the IPM, a thermistor used as the temperature monitor for internal substrate is connected between “TH1” and “TH2” . Generally, one of terminals is connected to V_{SS}, and the other is pulled up to external power supply with pull-up resistor (Rp) externally. The temperature monitor example application is as follows please refer the Fig.10 and Fig.11 below.
5. The pull-down resistor 33 kΩ is provided internally at the signal input terminals. An external resistor of 2.2 kΩ to 3.3 kΩ should be added to reduce the influence of external wiring noise.
6. As protection of IPM to unusual current by a short circuit etc, it recommended installing shunt resistors and an over-current protection circuit outside. Moreover, for safety, a fuse on Vcc line is recommended.
7. Disconnection of terminals U, V, W, during normal motor operation will cause damage to IPM, use caution with this connections.
8. The “ITRIP” terminal (pin 17) is the input terminal to shut down. When VITRIP exceeds threshold (0.44 to 0.54 V), all IGBTs are turned off. And normal operation resumes 2 ms (typ) after over current condition is removed. Therefore, please turn all the input signal off (Low) in case of detecting error at the “FAULT” terminal.
9. When input pulse width is less than 1.0 μs, an output may not react to the pulse. (Both ON signal and OFF signal)

STK5F4U3C2D-E

The characteristic of thermistor

Parameter	Symbol	Conditions	Min	Typ.	Max	Unit
Resistance	R_{25}	$T_c = 25^\circ\text{C}$	97	100	103	$k\Omega$
Resistance	R_{100}	$T_c = 100^\circ\text{C}$	4.93	5.38	5.88	$k\Omega$
B-Constant (25 to 50°C)	B		4165	4250	4335	K
Temperature Range			-40		+125	$^\circ\text{C}$

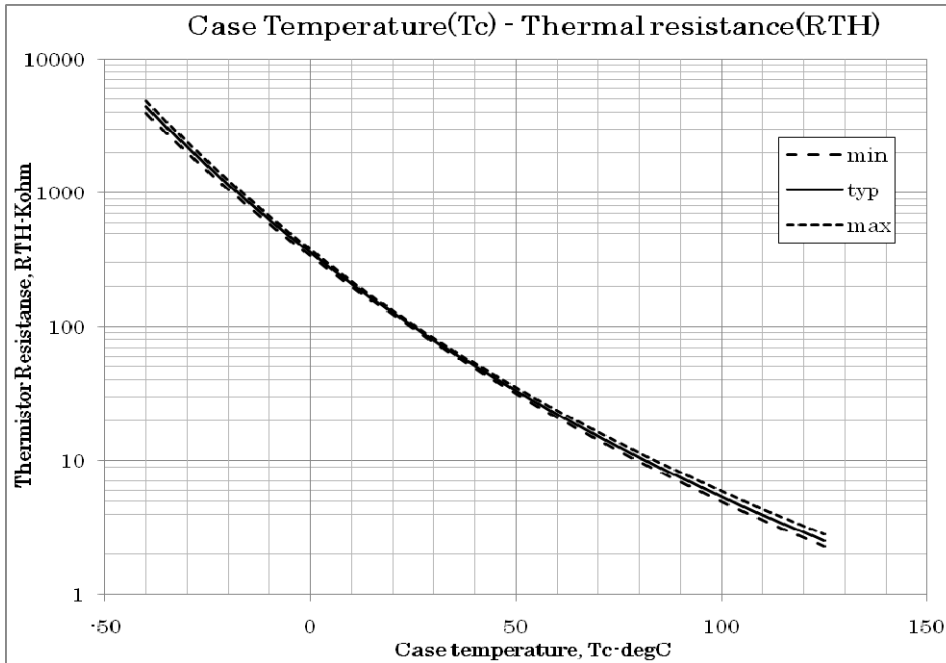

Fig.10 Variation of thermistor resistance with temperature

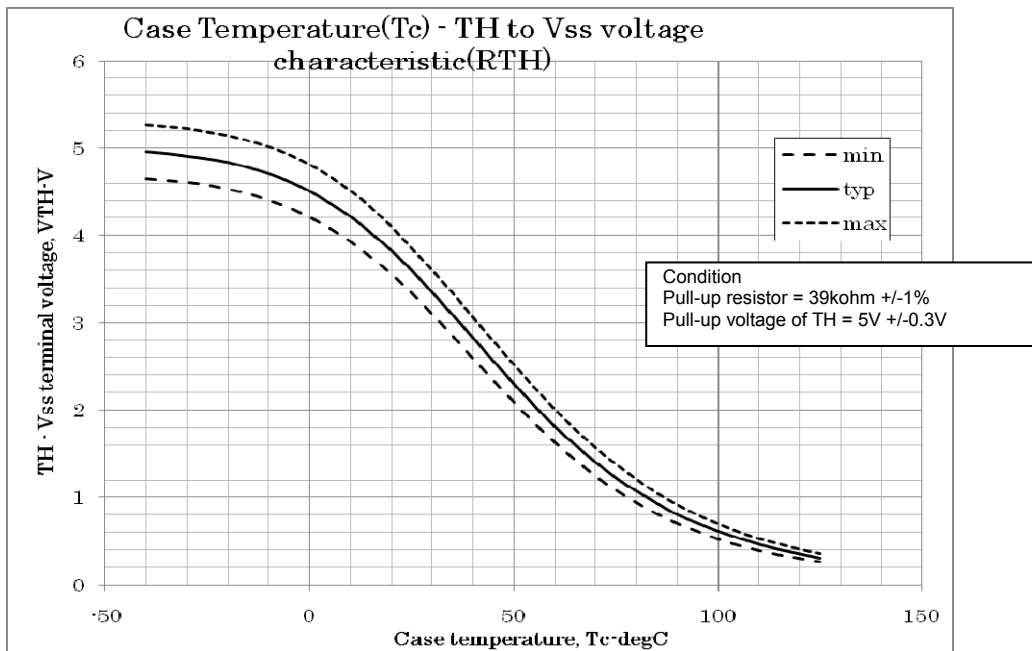

Fig.11 Variation of temperature sense voltage with thermistor temperature

STK5F4U3C2D-E

Io-f curve

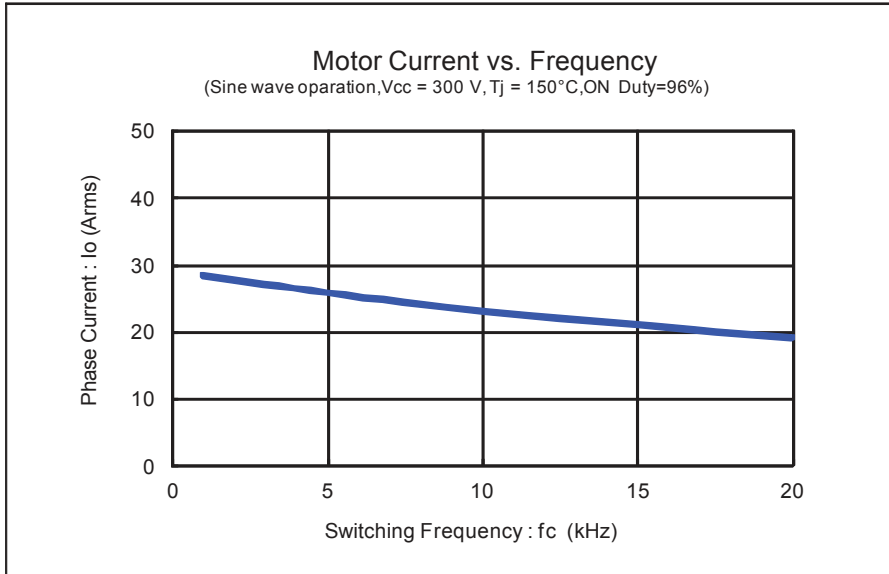

Fig.12 Maximum sinusoidal phase current as function of switching frequency at $T_c = 100^\circ\text{C}$, $V_{CC} = 300\text{ V}$

Switching waveform

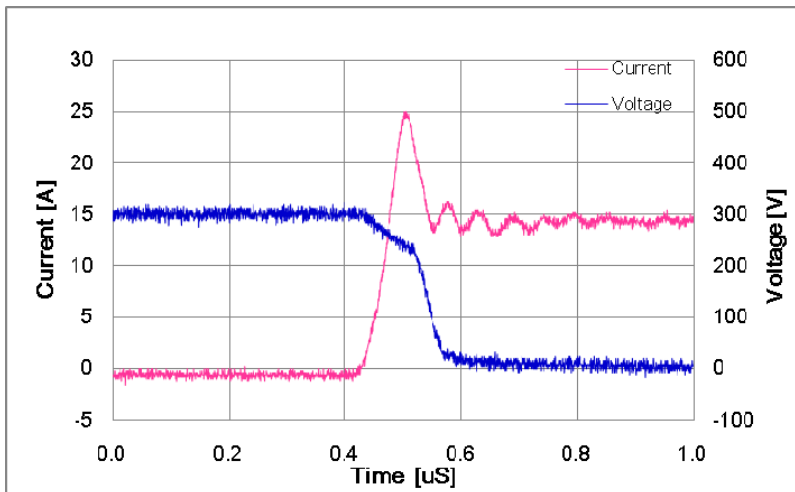

Fig. 13 IGBT Turn-on. Typical turn-on waveform $T_c = 100^\circ\text{C}$, $V_{CC} = 300\text{ V}$, $I_c = 15\text{ A}$

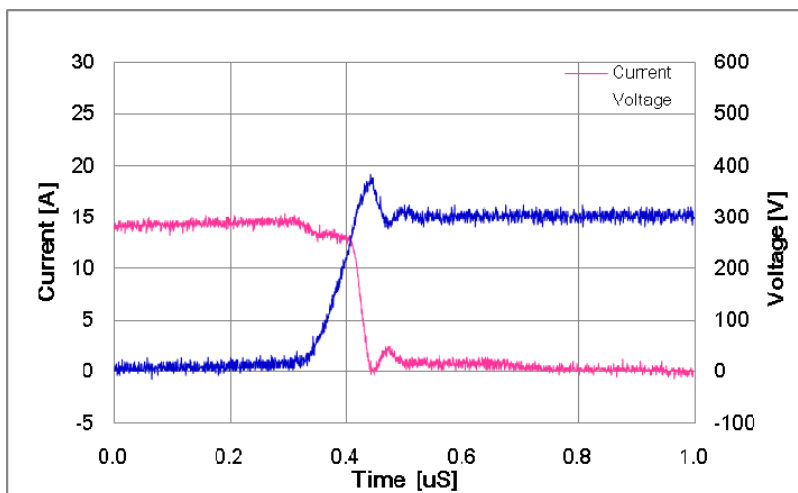

Fig. 14 IGBT Turn-off. Typical turn-off waveform at $T_c = 100^\circ\text{C}$, $V_{CC} = 300\text{ V}$, $I_c = 15\text{ A}$

CB capacitor value calculation for Boot strap circuit

Calculate condition

Item	Symbol	Value	Unit
Upper side power supply	VBS	15	V
Total gate charge of output power IGBT at 15 V	Qg	0.266	μC
Upper side power supply low voltage protection	UVLO	12	V
Upper side power dissipation	IDMAX	400	μA
ON time required for CB voltage to fall from 15 V to UVLO	TONMAX	-	s

Capacitance calculation formula

Ton-max is upper arm maximum on time equal the time when the CB voltage falls from 15 V to the upper limit of Low voltage protection level.

"Ton-maximum" of upper side is the time that CB decreases 15 V to the maximum low voltage protection of the upper side (12 V).

Thus, CB is calculated by the following formula.

$$VD \times CB - Qg - IDmax \times Ton-max = UVLO \times CB$$

$$CB = (Qg + IDmax \times Ton-max) / (VD - UVLO)$$

The relationship between Ton-max and CB becomes as follows.
 Recommend Cb is approximately 3 times of above calculated value.
 Please make the decision by the evaluation with the set

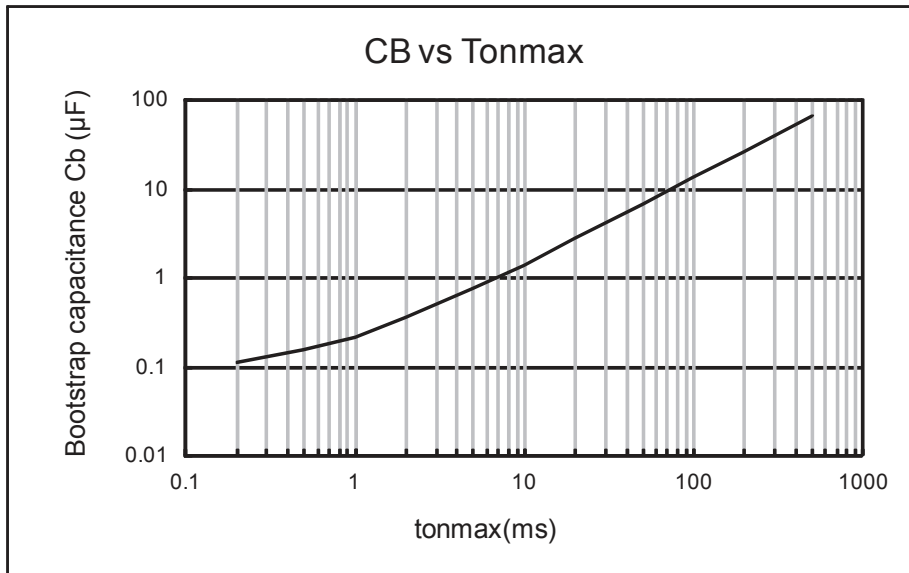

Fig.15 Ton-max vs CB characteristic

STK5F4U3C2D-E

PACKAGE DIMENSIONS

unit : mm

HYBRID INTEGRATED MODULE

CASE MODAW

ISSUE O

Missing Pin : 3,6,9,29,33,37,41

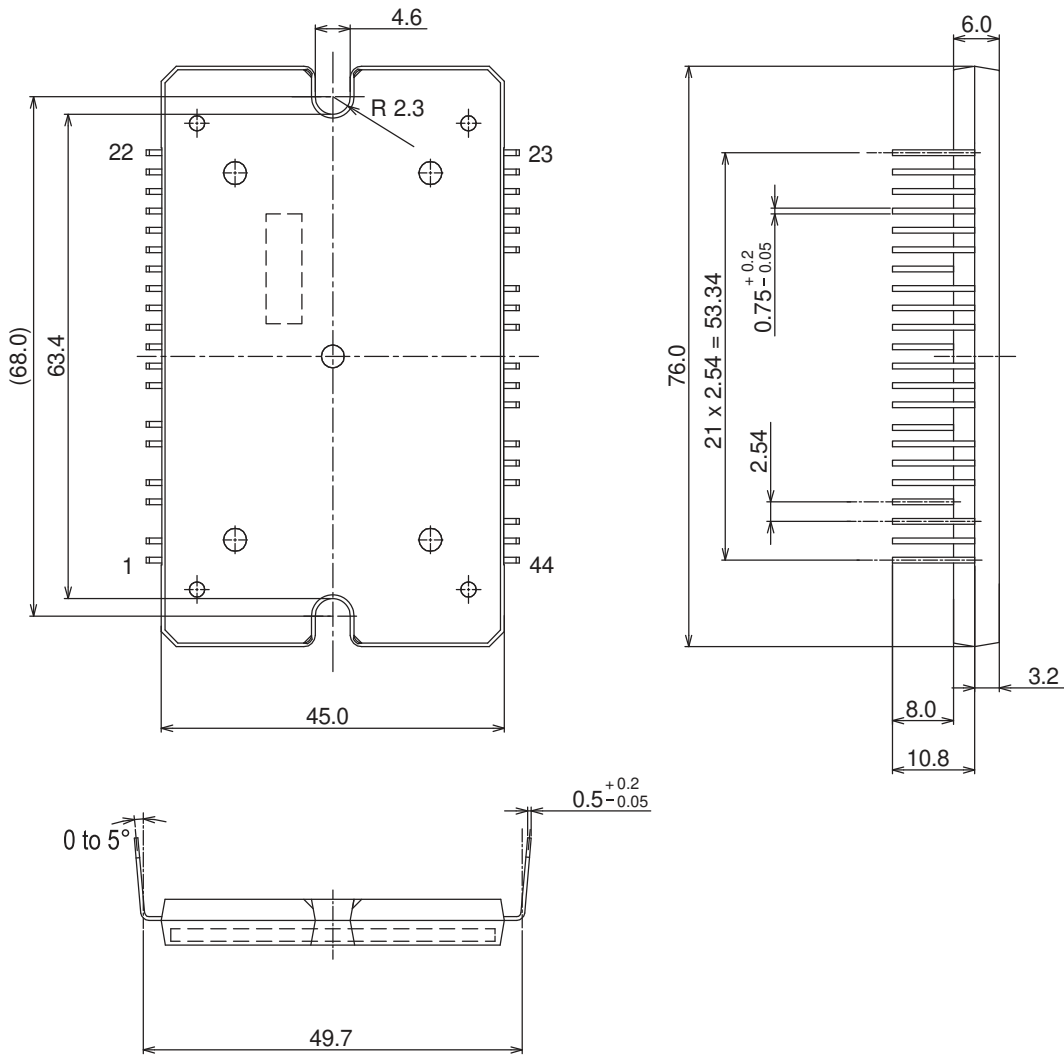

STK5F4U3C2D-E

ORDERING INFORMATION

Device	Package	Shipping (Qty / Packing)
STK5F4U3C2D-E	MODAW / 610AC-DIP4-UL (Pb-Free)	6 / Tube

ON Semiconductor and the ON Semiconductor logo are trademarks of Semiconductor Components Industries, LLC dba ON Semiconductor or its subsidiaries in the United States and/or other countries. ON Semiconductor owns the rights to a number of patents, trademarks, copyrights, trade secrets, and other intellectual property. A listing of ON Semiconductor's product/patent coverage may be accessed at www.onsemi.com/site/pdf/Patent-Marking.pdf. ON Semiconductor reserves the right to make changes without further notice to any products herein. ON Semiconductor makes no warranty, representation or guarantee regarding the suitability of its products for any particular purpose, nor does ON Semiconductor assume any liability arising out of the application or use of any product or circuit, and specifically disclaims any and all liability, including without limitation special, consequential or incidental damages. Buyer is responsible for its products and applications using ON Semiconductor products, including compliance with all laws, regulations and safety requirements or standards, regardless of any support or applications information provided by ON Semiconductor. "Typical" parameters which may be provided in ON Semiconductor data sheets and/or specifications can and do vary in different applications and actual performance may vary over time. All operating parameters, including "Typicals" must be validated for each customer application by customer's technical experts. ON Semiconductor does not convey any license under its patent rights nor the rights of others. ON Semiconductor products are not designed, intended, or authorized for use as a critical component in life support systems or any FDA Class 3 medical devices or medical devices with a same or similar classification in a foreign jurisdiction or any devices intended for implantation in the human body. Should Buyer purchase or use ON Semiconductor products for any such unintended or unauthorized application, Buyer shall indemnify and hold ON Semiconductor and its officers, employees, subsidiaries, affiliates, and distributors harmless against all claims, costs, damages, and expenses, and reasonable attorney fees arising out of, directly or indirectly, any claim of personal injury or death associated with such unintended or unauthorized use, even if such claim alleges that ON Semiconductor was negligent regarding the design or manufacture of the part. ON Semiconductor is an Equal Opportunity/Affirmative Action Employer. This literature is subject to all applicable copyright laws and is not for resale in any manner.