

THC63LVD1022

30Bit Color/150Mpps Dual-Link LVDS to LVCMOS converter

General Description

The THC63LVD1022 LVDS (Low Voltage Differential Signaling) converter is designed to support pixel data transmission between Host and Flat Panel Display up to Full-HD 1080p resolutions.

The THC63LVD1022 receives dual channel LVDS data stream and transmits LVTTTL/LVCMOS data through Dual Pixel Link Input / Single Link output conversion.

At a transmit data of 150Mpixel/sec, 30bits/pixel and 5bits of timing and control data (HSYNC, VSYNC, DE) are received at an effective rate of 525Mbps per LVDS channel.

Application

- Security Camera / Industrial Camera
- Medium and Small Size Panel
- Tablet PC / Notebook PC
- Multi Function Printer
- Industrial Equipment
- Medical Equipment Monitor

Features

- 20MHz to 75MHz 30bits/pixel dual-Link LVDS input
- Up to 150MHz 30bit s/pixel single port LVCMOS output
- Operating Temperature Range : 0 to 85°C
- LVDS input skew margin: ±400ps at 75MHz
- Dual input / Single output mode [clkout = 2x clkin]
- Output Enable / Disable mode supported
- No Special Start-up Sequence Required
- 100pin TQFP Package
- 3.3V single voltage power supply.
- PLL requires no external components.
- Environmental laws and regulations compliance (ex. EU RoHS)

Block Diagram

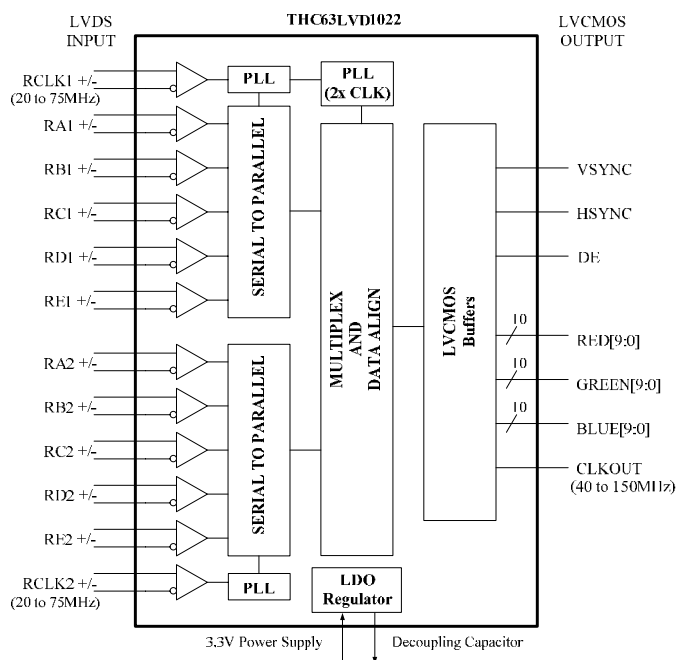

Figure 1. Block Diagram

Pin Diagram

THC63LVD1022

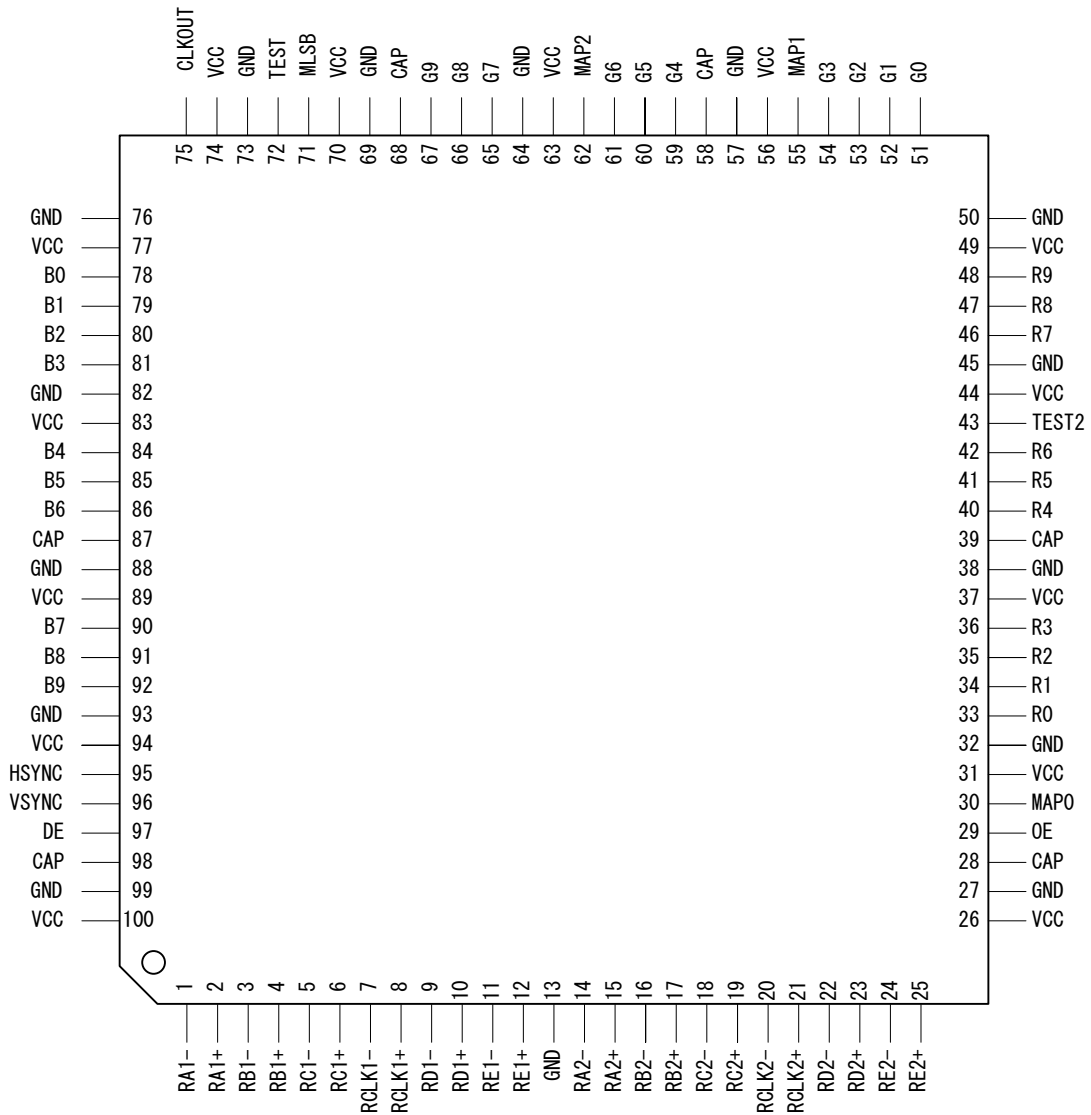

Figure 2. Pin Diagram

Pin Description

Pin Name	Pin #	Direction	Type	Description																																						
RA1+, RA1-	2, 1	Input	LVDS	LVDS 1st Link Data In.																																						
RB1+, RB1-	4, 3																																									
RC1+, RC1-	6, 5																																									
RD1+, RD1-	10, 9																																									
RE1+, RE1-	12, 11																																									
RCLK1+,RCLK1-	8, 7			LVDS Clock Input for 1st Link.																																						
RA2+, RA2-	15, 14			LVDS 2nd Link Data In.																																						
RB2+, RB2-	17, 16																																									
RC2+, RC2-	19, 18																																									
RD2+, RD2-	23, 22																																									
RE2+, RE2-	25, 24																																									
RCLK2+,RCLK2-	21, 20			LVDS Clock Input for 2nd Link.																																						
TEST, TEST2	72, 43			Reserved L: Normal Operation (Table. 10)																																						
OE	29			Output Enable H: Normal Operation L: Fix Output signals(Hold the previous logic value)																																						
MLSB	71	Output bit order selection H: MSB = 9 / LSB = 0 L: MSB = 0 / LSB = 9																																								
MAP2 ~ 0	62, 55, 30	Output color mapping selection																																								
		<table border="1"> <thead> <tr> <th rowspan="2">MAP0:1:2</th> <th colspan="3">RGB</th> </tr> <tr> <th>Rch</th> <th>Gch</th> <th>Bch</th> </tr> </thead> <tbody> <tr> <td>HHH</td> <td>R</td> <td>G</td> <td>B</td> </tr> <tr> <td>HHL</td> <td>R</td> <td>B</td> <td>G</td> </tr> <tr> <td>HLH</td> <td>B</td> <td>R</td> <td>G</td> </tr> <tr> <td>HLL</td> <td>B</td> <td>G</td> <td>R</td> </tr> <tr> <td>LHH</td> <td>G</td> <td>R</td> <td>B</td> </tr> <tr> <td>LHL</td> <td>G</td> <td>B</td> <td>R</td> </tr> <tr> <td>LLH</td> <td>R</td> <td>G</td> <td>B</td> </tr> <tr> <td>LLL</td> <td>R</td> <td>G</td> <td>B</td> </tr> </tbody> </table>	MAP0:1:2	RGB			Rch	Gch	Bch	HHH	R	G	B	HHL	R	B	G	HLH	B	R	G	HLL	B	G	R	LHH	G	R	B	LHL	G	B	R	LLH	R	G	B	LLL	R	G	B	LVTTL
MAP0:1:2	RGB																																									
	Rch	Gch	Bch																																							
HHH	R	G	B																																							
HHL	R	B	G																																							
HLH	B	R	G																																							
HLL	B	G	R																																							
LHH	G	R	B																																							
LHL	G	B	R																																							
LLH	R	G	B																																							
LLL	R	G	B																																							

Table 1. Pin Description

Pin Description (Continued)

Pin Name	Pin #	Direction	Type	Description
DE	97	Output	LVCMOS	Data Enable Output
VSYNC	96			Vsync Output
HSYNC	95			Hsync Output
R9 ~ 0	48, 47, 46, 42, 41, 40, 36, 35, 34, 33			Pixel Data Output(Rch)
G9 ~ 0	67, 66, 65, 61, 60, 59, 54, 53, 52, 51			Pixel Data Output(Gch)
B9 ~ 0	92, 91, 90, 86, 85, 84, 81, 80, 79, 78			Pixel Data Output(Bch)
CLKOUT	75			Clock Output
VCC	26, 31, 37, 44, 49, 56, 63, 70, 74, 77, 83, 89, 94, 100	-		Power Supply Pins
GND	13, 27, 32, 38, 45, 50, 57, 64, 69, 73, 76, 82, 88, 93, 99			Ground Pins
CAP	28, 39, 58, 68, 87, 98			Decoupling cap. External 0.1uF or more capacitance required.

Table 2. Pin Description

Absolute Maximum Ratings

Parameter	Min	Max	Unit
Supply Voltage (VCC)	-0.3	+4.0	V
LVC MOS/TTL Input Voltage	-0.3	VCC + 0.3	V
LVDS Input Pin	-0.3	VCC + 0.3	V
Junction Temperature	-	+125	°C
Storage Temperature	-55	+125	°C

Table 3. Absolute Maximum Rating

Recommended Operating Conditions

Symbol	Parameter	Min	Typ	Max	Unit	
-	All Supply Voltage	3.0	3.3	3.6	V	
Ta	Operating Ambient Temperature	0	25	+85	°C	
-	Clock Frequency	LVDS Input	20	-	75	MHz
		LVC MOS Output	40	-	150	

Table 4. Recommended Operating Conditions

“Absolute Maximum Ratings” are those values beyond which the safety of the device can not be guaranteed. They are not meant to imply that the device should be operated at these limits. The tables of “Electrical Characteristics” specify conditions for device operation.

“Absolute Maximum Rating” values also include behavior of overshooting and undershooting.

Equivalent LVDS Input Schematic Diagram

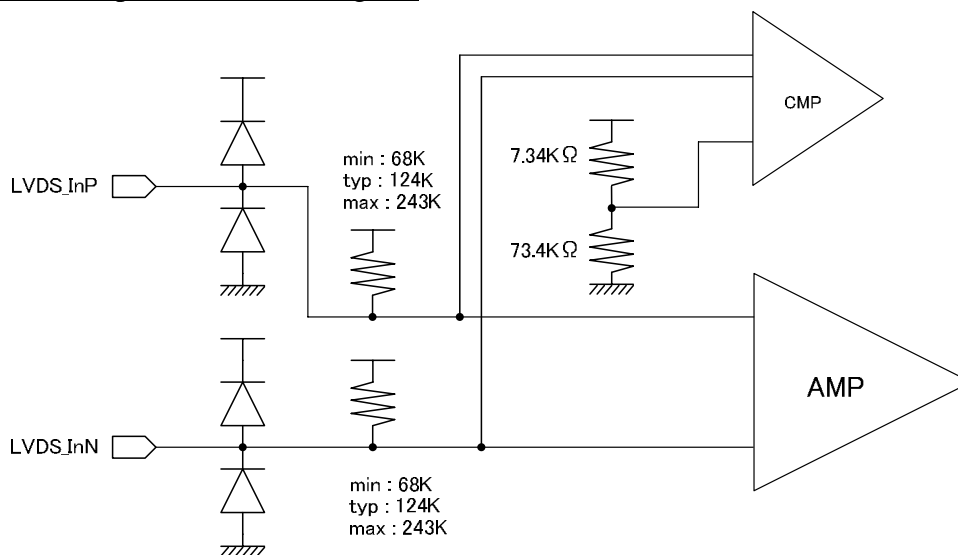

Figure 3. LVDS Input Schematic Diagram

Power Consumption

Over recommended operating supply and temperature range unless otherwise specified

Symbol	Parameter	Conditions	Typ*	Max	Unit
I _{RCCW}	LVDS Receiver Operating Current Gray Scale Pattern (Fig.4)	RL=100Ω, CL=5pF, RCLK=75MHz	139	-	mA
	LVDS Receiver Operating Current Worst Case Pattern (Fig.5)	RL=100Ω, CL=5pF, RCLK=75MHz	-	-	mA

* Typ values are at the conditions of VCC=3.3V and Ta = +25°C

Table 5. Power Consumption

Grayscale Pattern

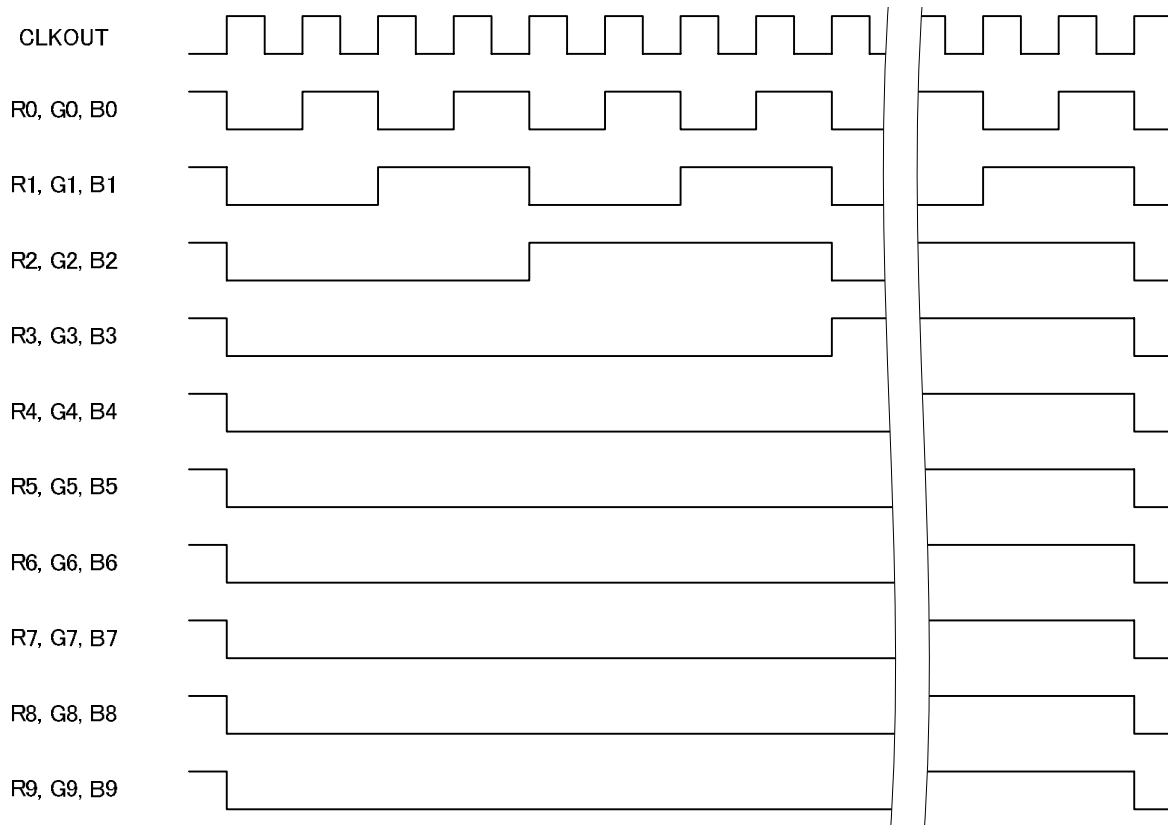

Figure 4. Grayscale Pattern

Worst Case Pattern

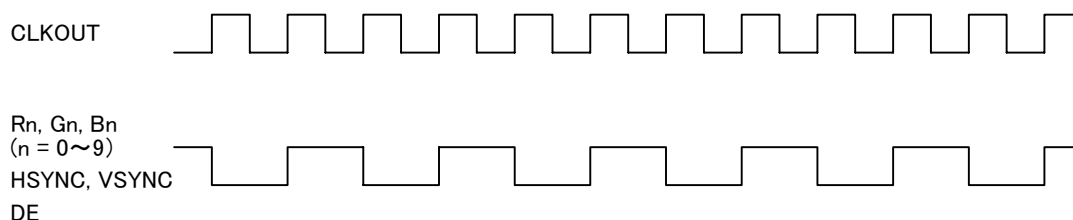

Figure 5. Worst Case Pattern

Electrical Characteristics

LVC MOS/TTL DC Specifications

Over recommended operating supply and temperature range unless otherwise specified

Symbol	Parameter	Conditions	Min	Typ*	Max	Unit
V _{IH}	High Level Input Voltage	RS=VCC or GND	2.0	-	VCC	V
V _{IL}	Low Level Input Voltage	RS=VCC or GND	GND	-	0.8	V
VOH	High Level Output Voltage	I _{OH} =12mA(Data), 16mA(Clk)	2.4	-	-	V
VOL	Low Level Output Voltage	I _{OH} =12mA(Data), 16mA(Clk)	-	-	0.4	V
I _{IL}	Input Leakage Current		-	-	±1	µA
P _D	Power Dissipation		-	0.46	-	W

*Typ values are at the conditions of VCC=3.3V and Ta = +25°C

Table 6. LVC MOS/TTL DC Specifications

LVDS Receiver DC Specifications

Over recommended operating supply and temperature range unless otherwise specified

Symbol	Parameter	Conditions	Min	Typ*	Max	Unit
V _{IC}	Differential Input Common Voltage		0.6	1.2	1.8	V
V _{ID}	Differential Voltage		100	-	600	mV
V _{TH}	Differential Input High Threshold	V _{IC} = 1.2V	-	-	100	mV
V _{TL}	Differential Input Low Threshold	V _{IC} = 1.2V	-100	-	-	mV
I _{INLVDS}	LVDS Input Current		-	-	±20	µA

*Typ values are at the conditions of VCC=3.3V and Ta = +25°C

Table 7. LVDS Receiver DC Specifications

LVC MOS/TTL & LVDS Receiver AC Specifications

Over recommended operating supply and temperature range unless otherwise specified

Symbol	Parameter	Min	Typ	Max	Unit	
t_{RCP}	CLK Period	RCLK1/2	13.3	-	50	ns
		CLKOUT	6.6	-	25	
t_{RCH}	CLKOUT High Time	$2/7 T_{RCP}$	$4/7 T_{RCP}$	$5/7 T_{RCP}$	ns	
t_{RCL}	CLKOUT Low Time	$5/7 T_{RCP}$	$3/7 T_{RCP}$	$2/7 T_{RCP}$	ns	
t_{DOUT}	LVC MOS Data OUT Period	6.6	-	25	ns	
t_{RS}	LVC MOS Data Setup to CLKOUT	2.0	-	4.6	ns	
t_{RH}	LVC MOS Data Hold to CLKOUT	2.0	-	4.6	ns	
t_{SK}	Receiver Skew Margin	-400	-	400	ps	
t_{RIP1}	Input Data Position0	$- t_{SK}$	0	$+ t_{SK}$	ns	
t_{RIP0}	Input Data Position1	$t_{RCIP}/7 - t_{SK}$	$t_{RCIP}/7$	$t_{RCIP}/7 + t_{SK}$	ns	
t_{RIP6}	Input Data Position2	$2t_{RCIP}/7 - t_{SK}$	$2t_{RCIP}/7$	$2t_{RCIP}/7 + t_{SK}$	ns	
t_{RIP5}	Input Data Position3	$3t_{RCIP}/7 - t_{SK}$	$3t_{RCIP}/7$	$3t_{RCIP}/7 + t_{SK}$	ns	
t_{RIP4}	Input Data Position4	$4t_{RCIP}/7 - t_{SK}$	$4t_{RCIP}/7$	$4t_{RCIP}/7 + t_{SK}$	ns	
t_{RIP3}	Input Data Position5	$5t_{RCIP}/7 - t_{SK}$	$5t_{RCIP}/7$	$5t_{RCIP}/7 + t_{SK}$	ns	
t_{RIP2}	Input Data Position6	$6t_{RCIP}/7 - t_{SK}$	$6t_{RCIP}/7$	$6t_{RCIP}/7 + t_{SK}$	ns	
t_{RPLL}	Phase Lock Loop Set	-	-	1	ms	

* Typ values are at the conditions of VCC=3.3V and Ta = +25°C

Table 8. LVC MOS/TTL & LVDS Receiver AC Specifications

AC Timing Diagrams

LVC MOS Output

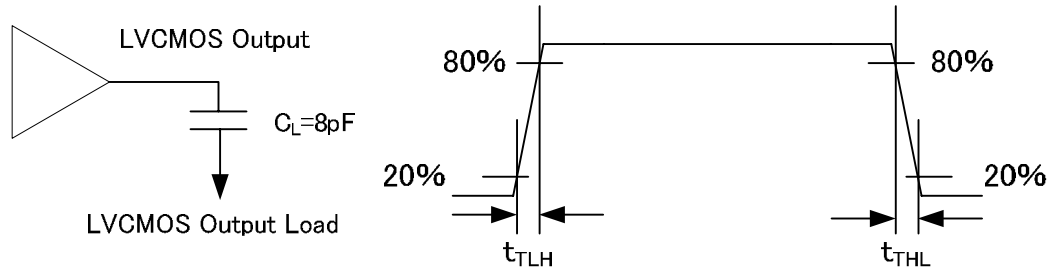

Figure 6. CLKOUT Transmission Time

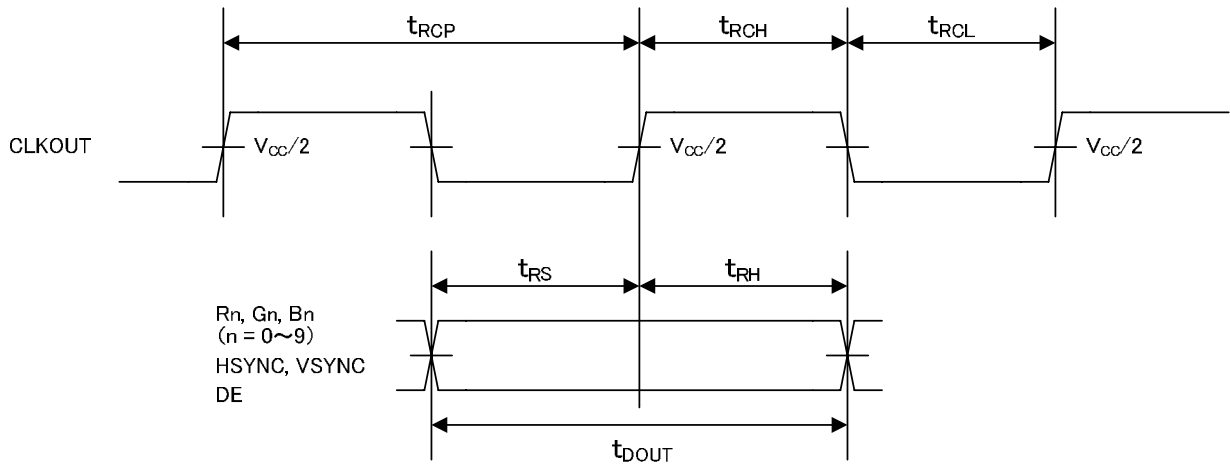

Figure 7. CLKOUT Period, High/Low Time, Setup/Hold Timing

LVDS Input Data Position

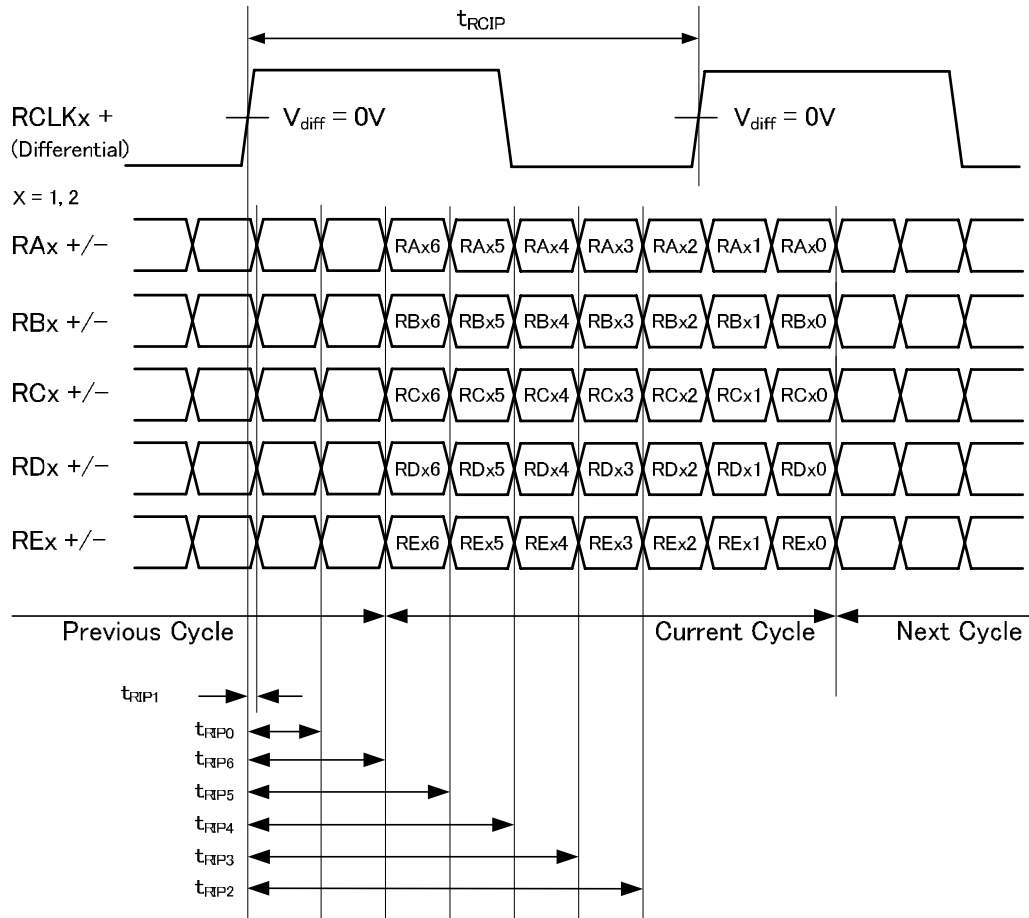

Figure 8. LVDS Input Data Position

Phase Lock Loop Set Time

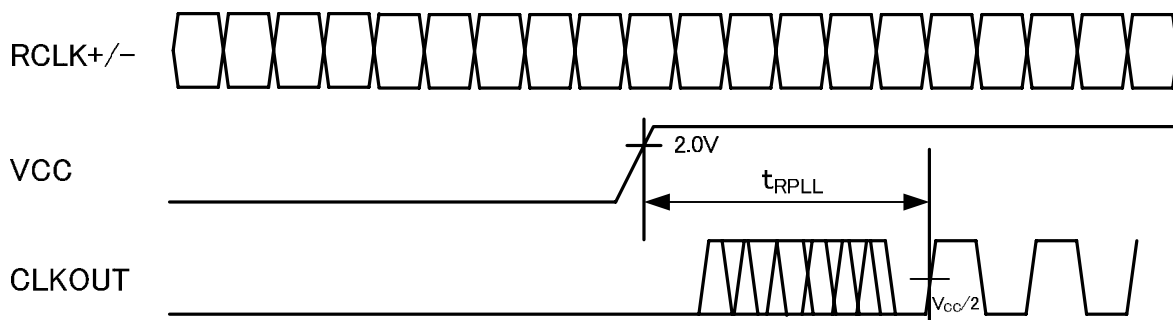

Figure 9. PLL Lock Set Time

LVDS Data Timing Diagram

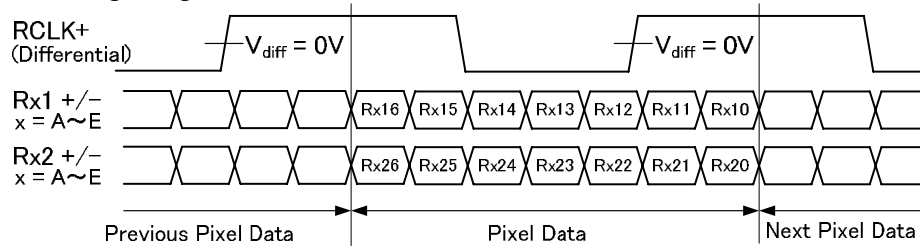

Figure 10. LVDS Data Timing Diagram

LVDS Input Data Mapping (MLSB=High, MAP[2:0]=High)

LVDS Input Data (1 st Pixel Data)	1 st pix data	LVDS Input Data (2 nd Pixel Data)	2 nd pix data
RA10	R4 (n)	RA20	R4 (n+1)
RA11	R5 (n)	RA21	R5 (n+1)
RA12	R6 (n)	RA22	R6 (n+1)
RA13	R7 (n)	RA23	R7 (n+1)
RA14	R8 (n)	RA24	R8 (n+1)
RA15	R9 (n)	RA25	R9 (n+1)
RA16	G4 (n)	RA26	G4 (n+1)
RB10	G5 (n)	RB20	G5 (n+1)
RB11	G6 (n)	RB21	G6 (n+1)
RB12	G7 (n)	RB22	G7 (n+1)
RB13	G8 (n)	RB23	G8 (n+1)
RB14	G9 (n)	RB24	G9 (n+1)
RB15	B4 (n)	RB25	B4 (n+1)
RB16	B5 (n)	RB26	B5 (n+1)
RC10	B6 (n)	RC20	B6 (n+1)
RC11	B7 (n)	RC21	B7 (n+1)
RC12	B8 (n)	RC22	B8 (n+1)
RC13	B9 (n)	RC23	B9 (n+1)
RC14	HSYNC	RC24	-
RC15	VSYNC	RC25	-
RC16	DE	RC26	-
RD10	R2 (n)	RD20	R2 (n+1)
RD11	R3 (n)	RD21	R3 (n+1)
RD12	G2 (n)	RD22	G2 (n+1)
RD13	G3 (n)	RD23	G3 (n+1)
RD14	B2 (n)	RD24	B2 (n+1)
RD15	B3 (n)	RD25	B3 (n+1)
RD16	-	RD26	-
RE10	R0 (n)	RE20	R0 (n+1)
RE11	R1 (n)	RE21	R1 (n+1)
RE12	G0 (n)	RE22	G0 (n+1)
RE13	G1 (n)	RE23	G1 (n+1)
RE14	B0 (n)	RE24	B0 (n+1)
RE15	B1 (n)	RE25	B1 (n+1)
RE16	-	RE26	-

Table 9. LVDS Input Data Mapping

Output Disable Mode

Input Signal	Normal Mode Setting	Output Disable Mode Setting
OE	H	L
TEST	L	H
TEST2	L	L
MAP0	X	H
MAP1	X	H
MAP2	X	H
Other Input Signals	X	X

Table 10. Output Disable Mode Setting

Output Signal	Normal Mode	Output Disable Mode
B9	Normal Operation	L
Other Output Signals		Hi-Z

Table 11. Output Disable Mode Signal Definition

Typical Connection

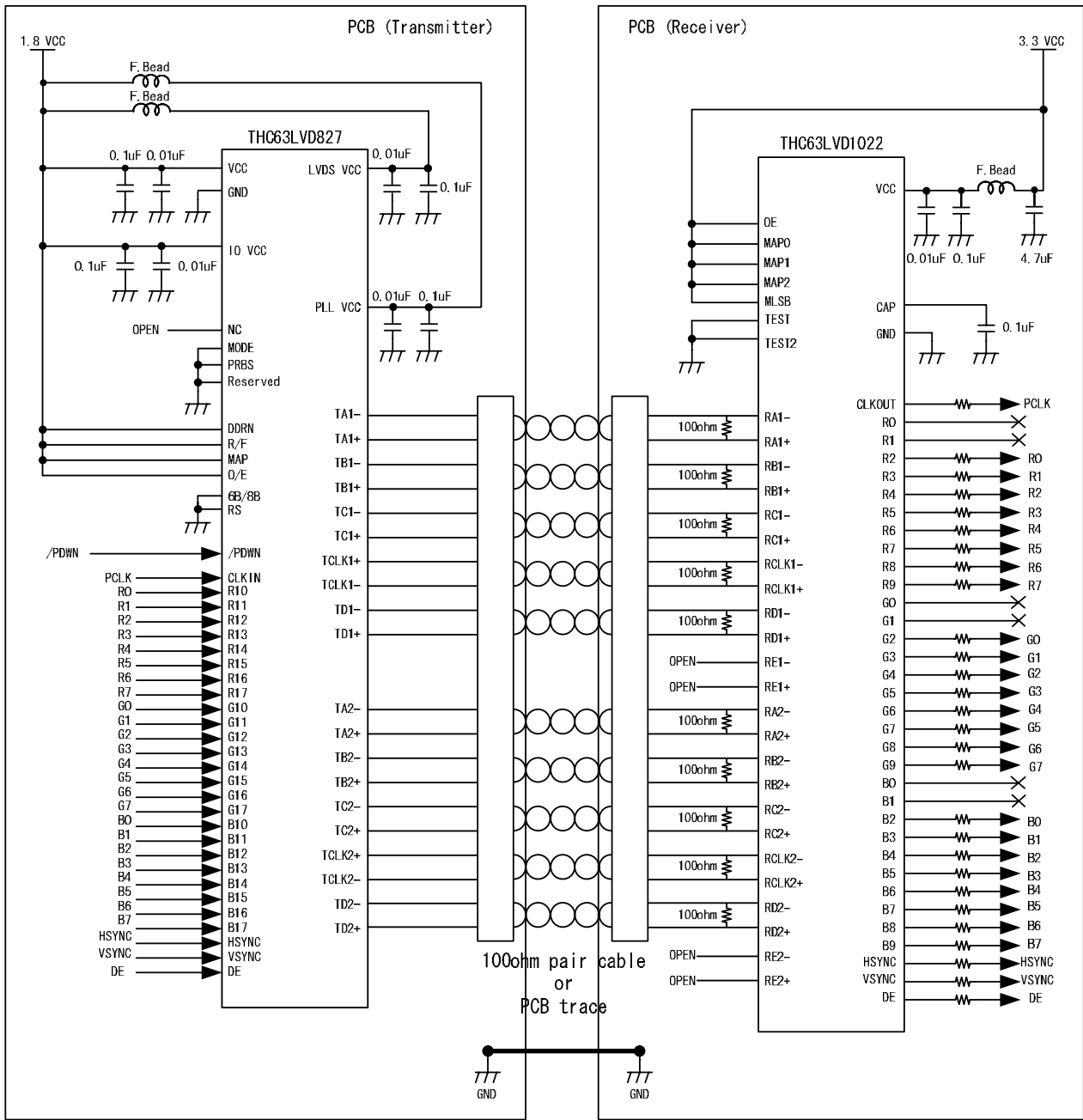

Figure 11. Typical Connection Diagram

Notes

1) Cable Connection and Disconnection

Do not connect and disconnect the LVDS cable, when the power is supplied to the system.

2) GND Connection

Connect each GND of the PCB which THC63LVD1022 and LVDS-Tx on it. It is better for EMI reduction to place GND cable as close to LVDS cable as possible.

3) Multi Drop Connection

Multi drop connection is not recommended.

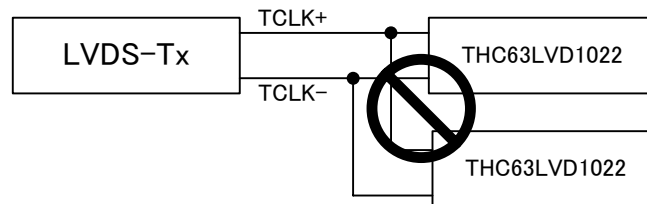

Figure 12. Multi Drop Connection

4) Asynchronous use

Asynchronous using such as following system is not recommended.

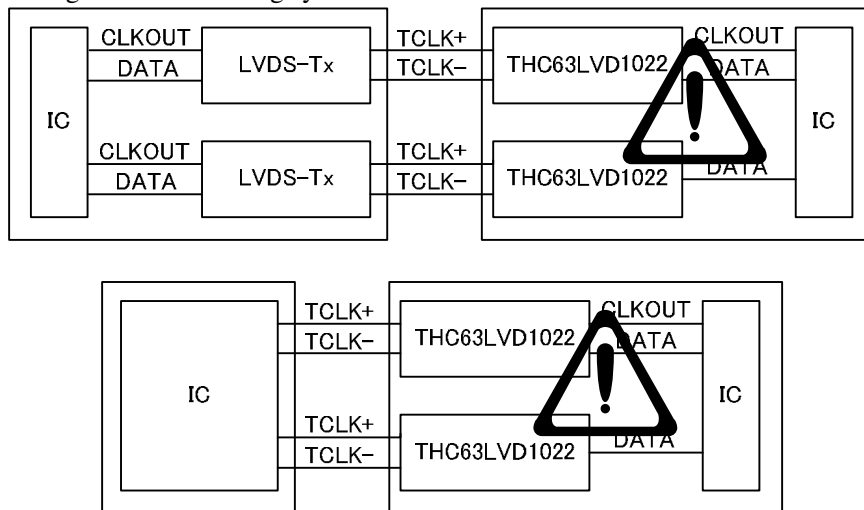

Figure 13. Asynchronous Use

Package

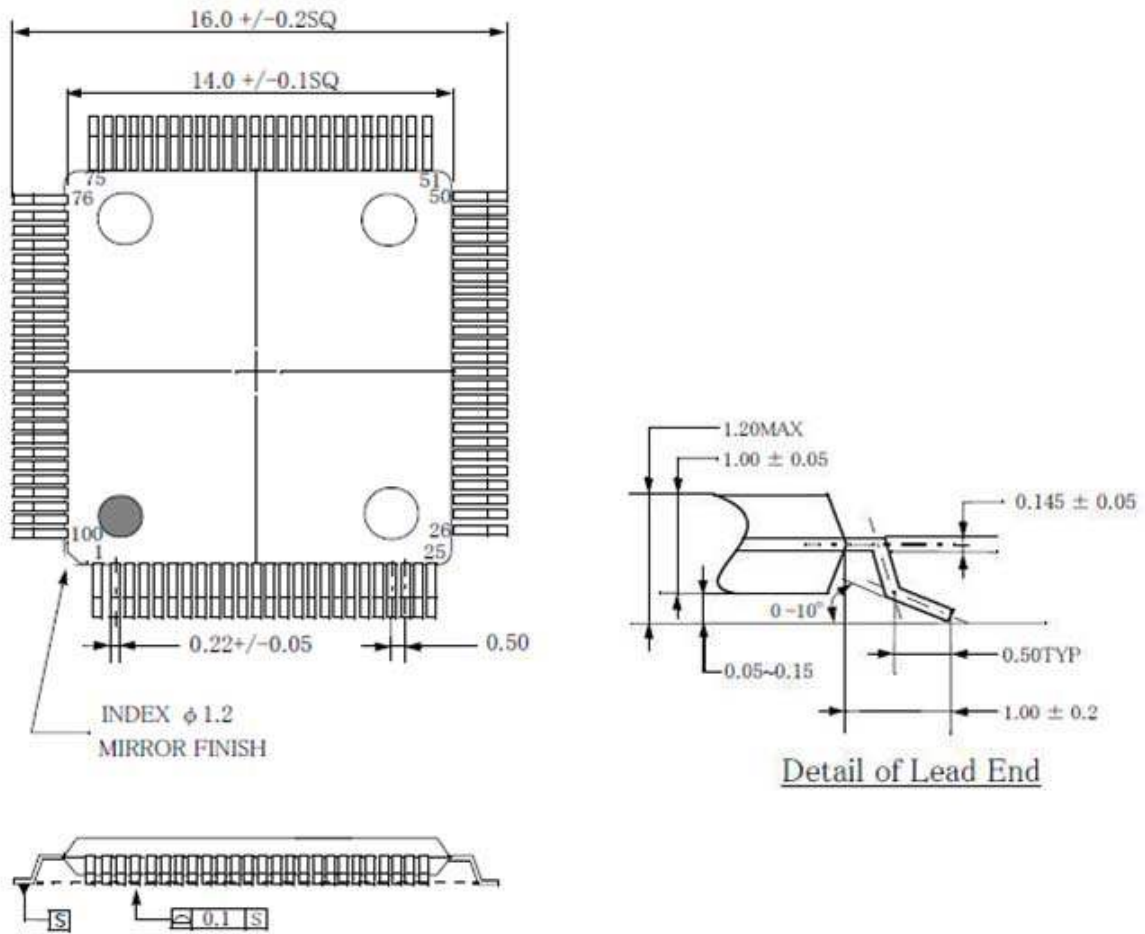

Figure 14. Package Diagram

Reference of Land Pattern

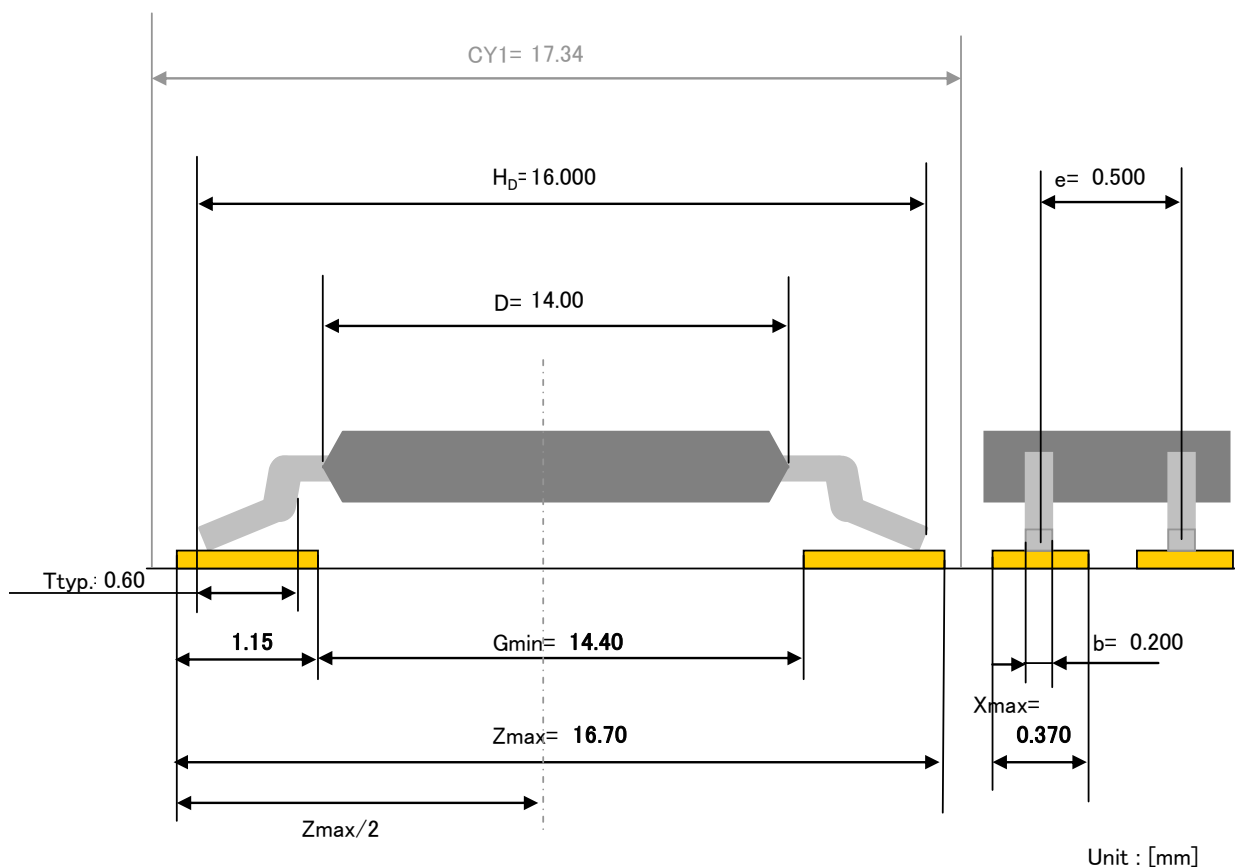

Figure 15. Reference of Land Pattern

The recommendation mounting method of THine device is reflow soldering.
 The reference pattern is using the calculation result on condition of reflow soldering.

Notes

This land pattern design is a calculated value based on JEITA ET-7501.
 Please take into consideration in an actual substrate design about enough the ease of mounting, the intensity of connection, the density of mounting, and the solder paste used, etc... The optimal land pattern size changes with these parameters. Please use the value shown by the land pattern as reference data.

Notices and Requests

1. The product specifications described in this material are subject to change without prior notice.
2. The circuit diagrams described in this material are examples of the application which may not always apply to the customer's design. We are not responsible for possible errors and omissions in this material. Please note if errors or omissions should be found in this material, we may not be able to correct them immediately.
3. This material contains our copyright, know-how or other proprietary. Copying or disclosing to third parties the contents of this material without our prior permission is prohibited.
4. Note that if infringement of any third party's industrial ownership should occur by using this product, we will be exempted from the responsibility unless it directly relates to the production process or functions of the product.
5. This product is presumed to be used for general electric equipment, not for the applications which require very high reliability (including medical equipment directly concerning people's life, aerospace equipment, or nuclear control equipment). Also, when using this product for the equipment concerned with the control and safety of the transportation means, the traffic signal equipment, or various Types of safety equipment, please do it after applying appropriate measures to the product.
6. Despite our utmost efforts to improve the quality and reliability of the product, faults will occur with a certain small probability, which is inevitable to a semi-conductor product. Therefore, you are encouraged to have sufficiently redundant or error preventive design applied to the use of the product so as not to have our product cause any social or public damage.
7. Please note that this product is not designed to be radiation-proof.
8. Customers are asked, if required, to judge by themselves if this product falls under the category of strategic goods under the Foreign Exchange and Foreign Trade Control Law.

THine Electronics, Inc.

sales@thine.co.jp