

STRAIGHT PLUG CRIMP -

R203.073.000

CABLE 2/50

Series : **SSMB**

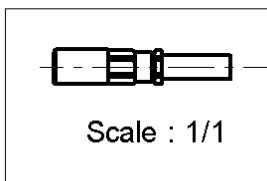
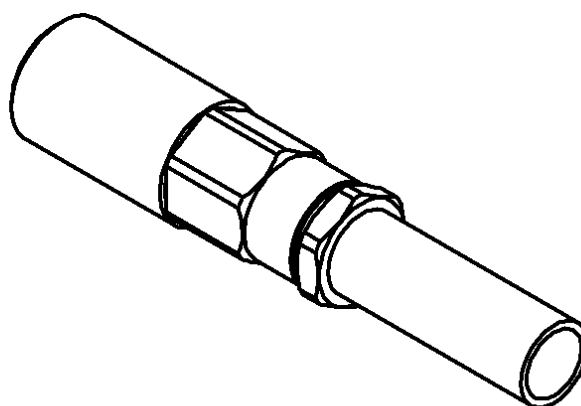
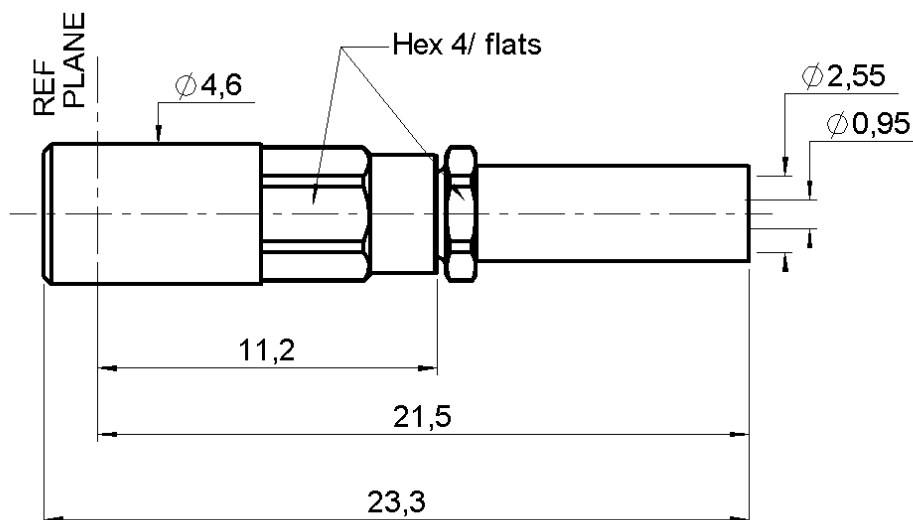

All dimensions are in mm.



COMPONENTS	MATERIALS	PLATINGS (µm)
BODY	BRASS	GOLD 0.5 OVER NICKEL 2
CENTER CONTACT	BERYLLIUM COPPER	GOLD 1.3 OVER NICKEL 2
OUTER CONTACT	BERYLLIUM COPPER	GOLD 0.5 OVER NICKEL 2
INSULATOR	PTFE	
GASKET	-	
OTHERS PARTS	BRASS	GOLD 0.2 OVER NICKEL 2
-	-	-
-	-	-

Issue : 0322 C

In the effort to improve our products, we reserve the right to make changes judged to be necessary.



STRAIGHT PLUG CRIMP -

R203.073.000

CABLE 2/50

Series : **SSMB**

PACKAGING

Standard	Unit	Other
100	-	Contact us

SPECIFICATION

CABLE ASSEMBLY

ELECTRICAL CHARACTERISTICS

Stripping	a	b	c	d	e	f
mm	3.50	4.00	12.0	0.00	8.50	0.00

Impedance		50	Ω
Frequency		0-4	GHz
VSWR	1.33 +	0.020	x F(GHz) Maxi
Insertion loss		0.30	\sqrt{F} (GHz) dB Maxi
RF leakage	- (NA	- F(GHz)) dB mini
Voltage rating		250	Veff Maxi
Dielectric withstanding voltage		500	Veff mini
Insulation resistance		1000	M Ω mini

Assembly instruction :

Recommended cable(s)
 KX 21
 RG 178
 RG 196
 RG 178 LC

Cable retention

- pull off **45** N mini
 - torque **NA** N.cm

MECHANICAL CHARACTERISTICS

TOOLING

Center contact retention			
Axial force – Mating end		8.9	N mini
Axial force – Opposite end		8.9	N mini
Torque		NA	N.cm mini

Part Number	Description	Hexagon
.	.	.
R282.235.003	CRIMPING DIES	2.67
R282.293.000	CRIMPING TOOL	-
R282.211.000	CRIMPING TOOL	2.67

Recommended torque			
Mating		NA	N.cm
Panel nut		NA	N.cm
Clamp nut		NA	N.cm
A/F clamp nut		0.000	mm

OTHERS CHARACTERISTICS

Mating life		500	Cycles mini
Weight		0.000	g

ENVIRONMENTAL

Operating temperature		-65/+165	$^{\circ}$ C
Hermetic seal		NA	Atm.cm3/s
Panel leakage		NA	

Issue : **0322 C**

In the effort to improve our products, we reserve the right to make changes judged to be necessary.



STRAIGHT PLUG CRIMP -

R203.073.000

CABLE 2/50

Series : **SSMB**

COMPONENTS

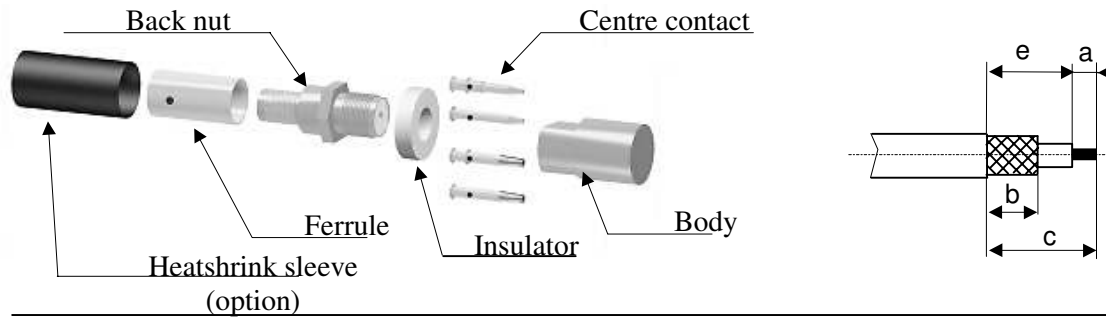

1

Slide the heatshrink sleeve onto the cable (Option).
Slide the ferrule onto the cable.
Position the ferrule's hole at the front if soldering.
Position the ferrule's hole at the back if crimping.
Strip the cable.

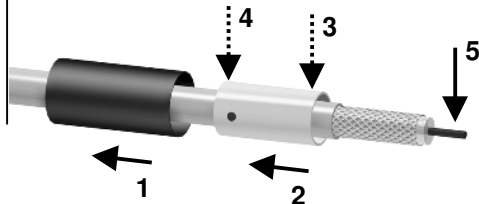

4

Slide the centre contact on until it bottoms against the insulator back nut.
Solder or crimp the contact (see connector TDS).



2

Fan the braid.
Slide the cable into the back nut.

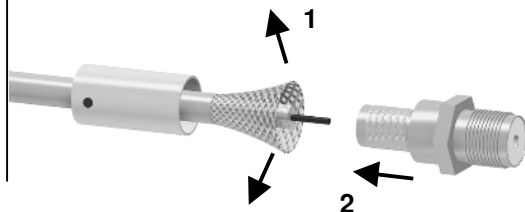

5

Screw the back nut into the connector body with the adapted wrench.
Recommended coupling torque 170 N cm.

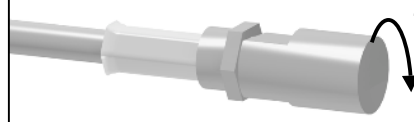

3

Slide the ferrule over the braid.
Crimp the ferrule with crimping tool (see connector TDS).

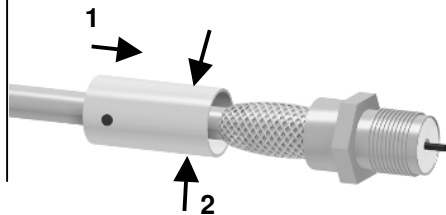

6

Slide the sleeve over the ferrule and heatshrink it in place (option).

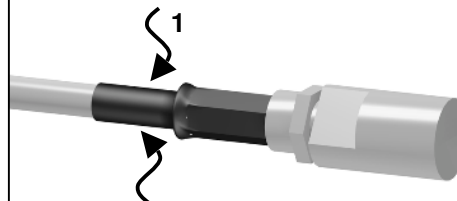

Issue : 0322 C

In the effort to improve our products, we reserve the right to make changes judged to be necessary.

