

©1961 BY AMP INCORPORATED. ALL RIGHTS RESERVED. AMP PRODUCTS COVERED BY PATENTS AND/OR PATENTS PENDING.

NUMBER 66053

REVISIONS				
ZONE	LTR	DESCRIPTION	DATE	APPROVED
	E-1	REDRAWN AND REVISED 1678	4-19-8	M.S. JH
	F	LOC'S WAS AB, DIST 12 WAS 39 9347	11-8-72	JP
	G	OBSOLETE -4 EA 970	1-31-79	DJA
	H	BRIGHT TIN-LEAD WAS BRIGHT TIN, EA1818	6-18-81	DS
✓	J	OBS -7, -8 & -9 ECN 53379	11-86	RS
✓	K	OBS -5 ECN 53815	2-27-87	RS
	L	REV PER DF-0357 TS	6/15/88	TS
	M	REV PER OH14-0139-05	1-26-06	PY RG

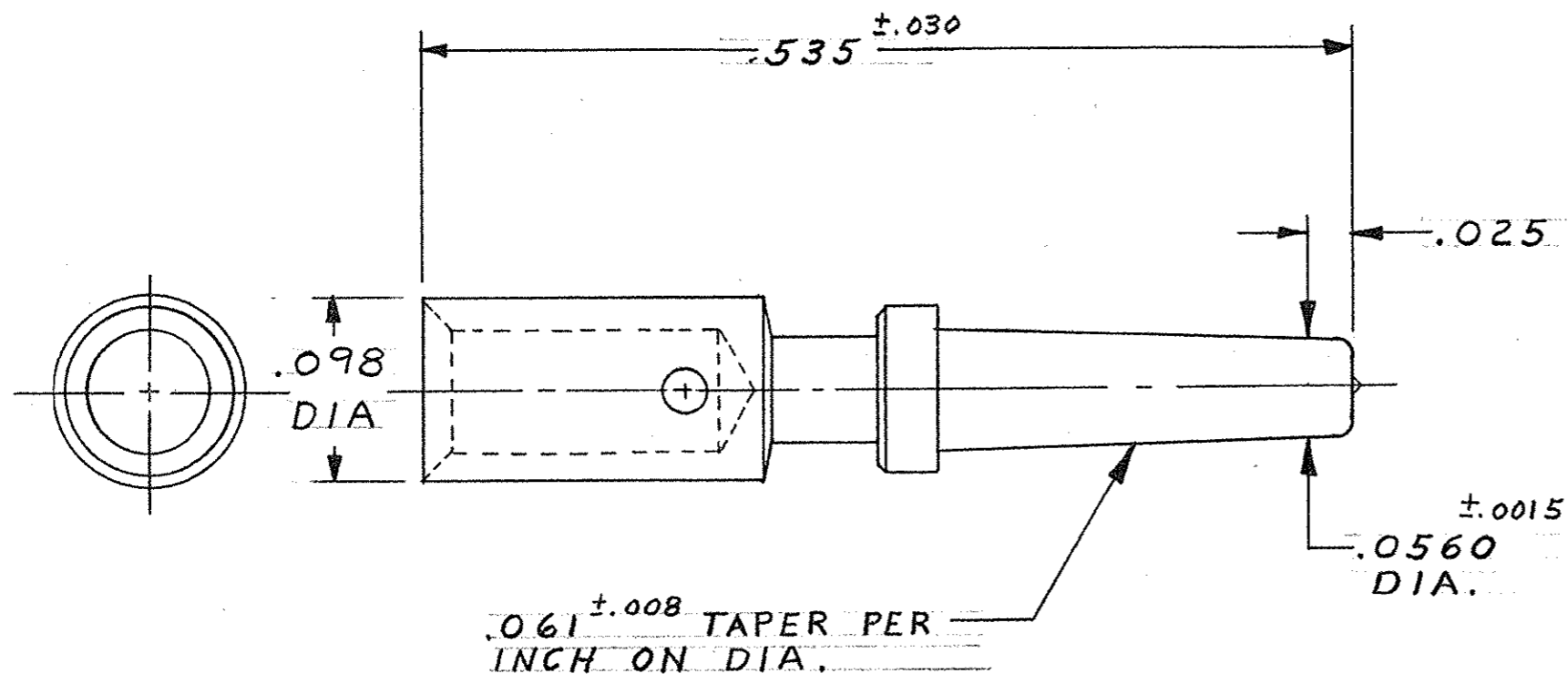

WIRE SIZE : #16

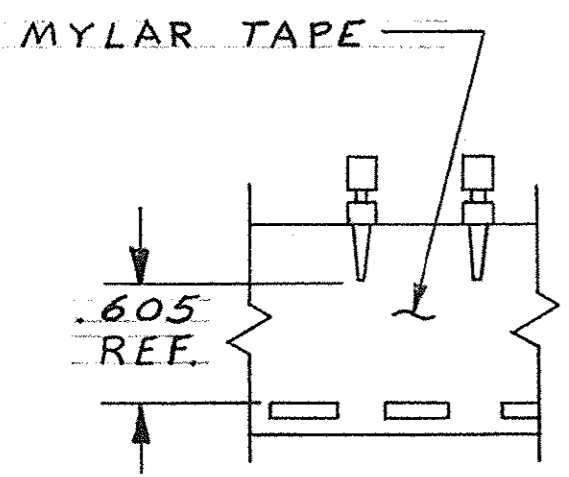

TAPE MOUNTED PART NO'S
66053-7, -8 & -9.

	5-66053-1	.0001 MATTE TIN
	66053-9	.00003 GOLD OVER .00005 NICKEL
	66053-8	SILVER -.0002 THICK
OBSOLETE	66053-7	BRIGHT TIN-LEAD .0001 THICK
	66053-5	.0002 GOLD OVER .000050 NICKEL
	66053-4	.0001 GOLD OVER .0001 NICKEL
	66053-3	.00003 GOLD OVER .00005 NICKEL
OBSOLETE	66053-2	SILVER -.0002 THICK
	66053-1	BRIGHT TIN-LEAD .0001 THICK
	PART NO.	FINISH

UNLESS OTHERWISE SPECIFIED DIM. ARE IN INCHES. TOLERANCES ON DECIMALS ± .015 ANGLES ± 1° 0'	CONTRACT NO.	AMP	AMP INCORPORATED HARRISBURG, PENNSYLVANIA		
	DR <i>m. Smith</i> 4-19-8		NAME PIN, TAPER, "53" SERIES		
MATERIAL BRASS	CHK <i>J.S. Heide</i> 5/10/68	DSGN APPD <i>W. Faller</i> 5-10-68	SIZE B	CODE IDENT NO. 00779	NUMBER 66053
AMP INFO 5300 LOC DF	HEAT TREAT	OTHER APPD	SCALE 10-1	WT CALC	ACTUAL SHEET
	FINISH SEE TABLE				