

- Max. propagation delay of 2200ps
- IEE min. of -70mA
- Industry standard 100K ECL levels
- Extended supply voltage option:
VEE = -4.2V to -5.5V
- Voltage and temperature compensation for improved noise immunity
- Internal 75KΩ input pull-down resistors
- 15% faster than Fairchild 300K
- Approximately 30% lower power than Fairchild 300K
- Function and pinout compatible with Fairchild F100K
- Available in 24-pin CERPACK and 28-pin PLCC packages

The SY100S360 is a dual parity checker/generator and is designed for use in high-performance ECL systems. The inputs are segmented into two groups of nine inputs each and the parity output is at a logic LOW when an even number of inputs are at a logic HIGH. In each group, one of the nine inputs (Ia, Ib) has a shorter propagation delay and, therefore, is ideal as the expansion input for parity generation of wider data.

A Compare output (C) is also provided which allows comparison of two 8-bit words. A logic LOW on the C output indicates a match. The inputs on this device have 75KΩ pull-down resistors.

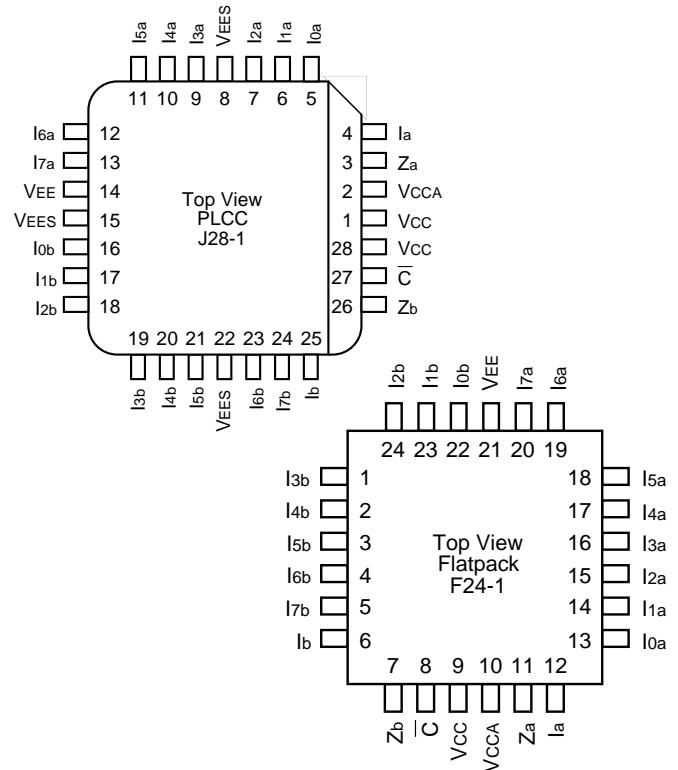
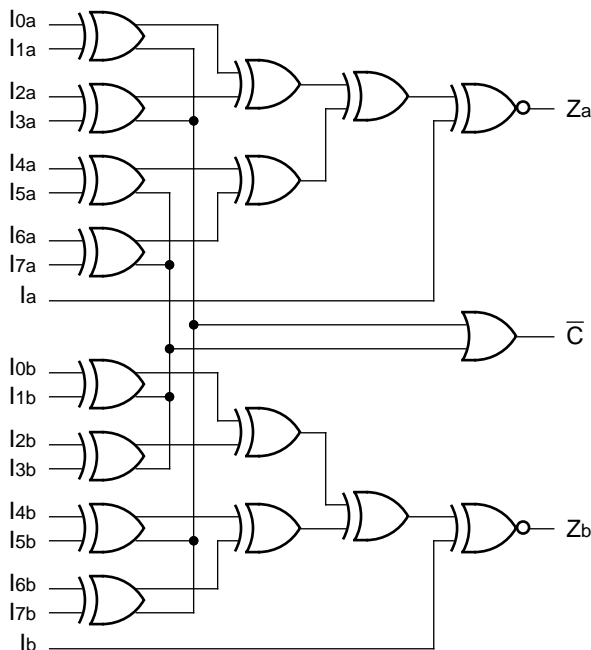

Pin	Function
Ia, Ib, Ina, Inb	Data Inputs (n = 1...7)
Za – Zb	Parity Odd Outputs
\bar{C}	Compare Output
VEES	VEE Substrate
VCCA	Vcco for ECL Outputs

Sum of High Inputs	Output Z
Even	HIGH
Odd	LOW

NOTE:

1. Comparator Function:

$$\bar{C} = (I_{0a} \oplus I_{1a}) + (I_{2a} \oplus I_{3a}) + (I_{4a} \oplus I_{5a}) + (I_{6a} \oplus I_{7a}) + (I_{0b} \oplus I_{1b}) + (I_{2b} \oplus I_{3b}) + (I_{4b} \oplus I_{5b}) + (I_{6b} \oplus I_{7b})$$

VEE = -4.2V to -5.5V unless otherwise specified; VCC = VCCA = GND

Symbol	Parameter	Min.	Typ.	Max.	Unit	Condition
I _{IH}	Input HIGH Current Ia, Ib Ina, Inb	—	—	300 200	μA	V _{IN} = V _{IH} (Max.)
I _{EE}	Power Supply Current	-70	-45	-30	mA	Inputs Open

CERPACK

VEE = -4.2V to -5.5V unless otherwise specified; VCC = VCCA = GND

Symbol	Parameter	TA = 0°C		TA = +25°C		TA = +85°C		Unit	Condition
		Min.	Max.	Min.	Max.	Min.	Max.		
t _{PLH} t _{PHL}	Propagation Delay Ina, Inb to Za, Zb	500	2300	500	2300	500	2300	ps	
t _{PLH} t _{PHL}	Propagation Delay Ina, Inb to \bar{C}	500	1800	500	1800	500	1800	ps	
t _{PLH} t _{PHL}	Propagation Delay Ia, Ib to Za, Zb	300	1000	300	1000	300	1000	ps	
t _{TLH} t _{THL}	Transition Time 20% to 80%, 80% to 20%	300	900	300	900	300	900	ps	

PLCC

VEE = -4.2V to -5.5V unless otherwise specified; VCC = VCCA = GND

Symbol	Parameter	TA = 0°C		TA = +25°C		TA = +85°C		Unit	Condition
		Min.	Max.	Min.	Max.	Min.	Max.		
t _{PLH} t _{PHL}	Propagation Delay Ina, Inb to Za, Zb	500	2200	500	2200	500	2200	ps	
t _{PLH} t _{PHL}	Propagation Delay Ina, Inb to \bar{C}	500	1700	500	1700	500	1700	ps	
t _{PLH} t _{PHL}	Propagation Delay Ia, Ib to Za, Zb	300	900	300	900	300	900	ps	
t _{TLH} t _{THL}	Transition Time 20% to 80%, 80% to 20%	300	900	300	900	300	900	ps	

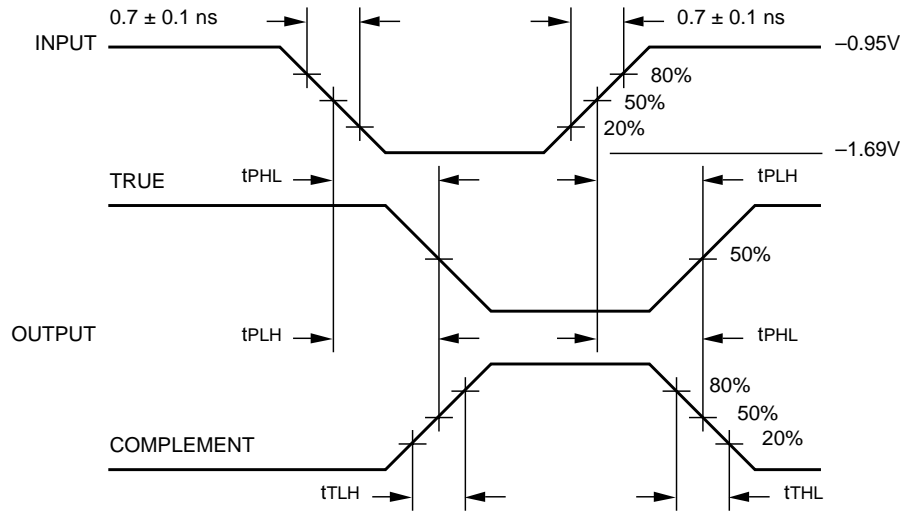

Propagation Delay and Transition Times

NOTE:

$V_{EE} = -4.2V$ to $-5.5V$ unless otherwise specified; $V_{CC} = V_{CCA} = GND$

Ordering Code	Package Type	Operating Range
SY100S360FC	F24-1	Commercial
SY100S360JC	J28-1	Commercial
SY100S360JCTR	J28-1	Commercial

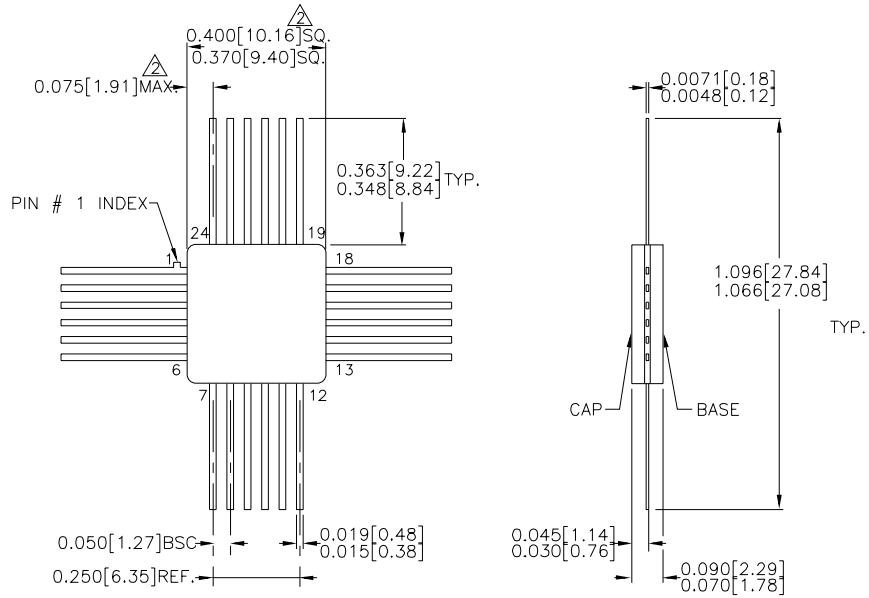

- NOTES:
1. DIMENSIONS ARE IN INCHES[MM].
 - △ THIS DIMENSION INCLUDES GLASS PROTRUSION AND CAP TO BASE ALIGNMENT TOLERANCES.
 3. DIMENSIONS SHOWN ARE MAX/MIN, WHERE NOTED.

Rev.03

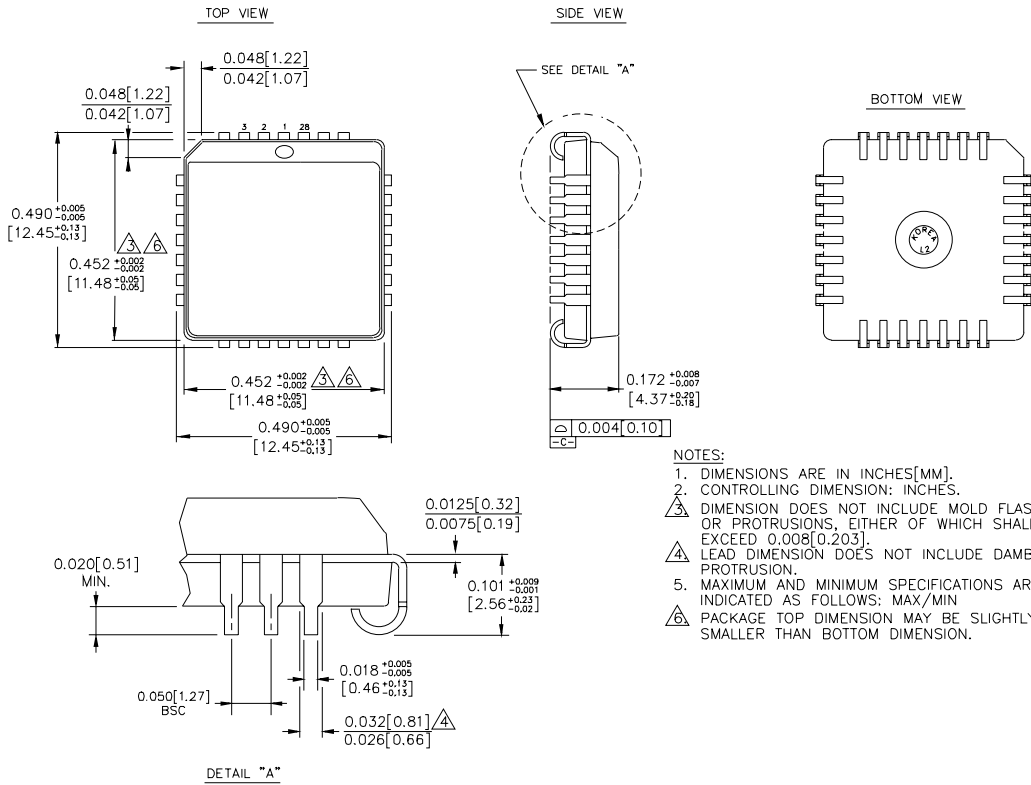

- NOTES:
1. DIMENSIONS ARE IN INCHES[MM].
 2. CONTROLLING DIMENSION: INCHES.
 3. DIMENSION DOES NOT INCLUDE MOLD FLASH OR PROTRUSIONS, EITHER OF WHICH SHALL NOT EXCEED 0.008[0.203].
 4. LEAD DIMENSION DOES NOT INCLUDE DAMBAR PROTRUSION.
 5. MAXIMUM AND MINIMUM SPECIFICATIONS ARE INDICATED AS FOLLOWS: MAX/MIN
 6. PACKAGE TOP DIMENSION MAY BE SLIGHTLY SMALLER THAN BOTTOM DIMENSION.

Rev. 03

MICREL-SYNERGY 3250 SCOTT BOULEVARD SANTA CLARA CA 95054 USA

TEL + 1 (408) 980-9191 FAX + 1 (408) 914-7878 WEB <http://www.micrel.com>

This information is believed to be accurate and reliable, however no responsibility is assumed by Micrel for its use nor for any infringement of patents or other rights of third parties resulting from its use. No license is granted by implication or otherwise under any patent or patent right of Micrel Inc.

© 2000 Micrel Incorporated