

Prepared		<b>Product Specifications</b> <b>AN17880A</b>	Ref No.	A-1
Checked			Total Page	7
Approved			Page No.	1

Structure	Silicon Monolithic Bipolar IC
Appearance	SSONF-16D DIL-16Pin Plastic Package (SO type)
Application	Low Frequency Amplifier
Function	Headphone amplifier IC with Center Amplifier

A	Absolute Maximum Ratings				
No.	Item	Symbol	Ratings	Unit	Note
1	Storage Temperature	Tstg	-55 ~ +150	° C	1
2	Operating Ambient Temperature	Topr	-25 ~ +75	° C	1
3	Operating Ambient Pressure	Popr	$1.013 \times 10^5 \pm 0.61 \times 10^5$ (1.0 ± 0.6)	Pa (atm)	
4	Operating Constant Gravity	Gopr	9,810 (1,000)	m / s <sup>2</sup> (G)	
5	Operating Shock	Sopr	4,900 (500)	m / s <sup>2</sup> (G)	
6	Power Supply Voltage	Vcc	4.6	V	2
7	Power Supply Current	Icc	200	mA	
8	Power Dissipation	PD	437	mW	3

Operating Supply Voltage Range	Vcc	1.8 V ~ 4.5 V
--------------------------------	-----	---------------

Note : 1) Ta = 25°C except storage temperature and operating ambient temperature.

Note : 2) At no - signal

Note : 3) At Ta = 70°C on PCB of the standard, 50mmX 50mmX 0.8mm glass - epoxy.

Eff. Date	Eff. Date	Eff. Date	Eff. Date	
9 Nov 2000				

Prepared		<b>Product Specifications</b> <b>AN17880A</b>	Ref No.	B-1
Checked			Total Page	7
Approved			Page No.	2

No.	Item	Symbol	Test Cct.	Condition	Limit			Unit	Note
					Min	Typ	Max		
<b>B</b> <b>Electrical Characteristics</b> (Ambient temperature is 25°C±2°C unless otherwise specified)									
1	Stand-by current	Istb	1	Vin = 0mV STB: ON	-	0.1	5.0	uA	
2	Quiescent Current 1	Icq 1	1	Vin = 0mV C-Amp: OFF	-	1.3	2.6	mA	
3	Quiescent Current 2	Icq 2	1	Vin = 0mV C-Amp: ON	-	1.6	3.2	mA	
4	Voltage Gain 1	Gv 1	1	Vout = -22dBv	5.5	8.3	10.5	dB	
5	Channel Balance	CB	1	Vout = -22dBv	-1.0	0	1.0	dB	
6	Maximum Power Output	Po	1	THD = 10% Vcc = 2V	5.0	9.0	-	mW	
7	Total Harmonic Distortion	THD	1	Vout = -12.2dBv	-	0.1	0.5	%	
8	Output Noise Voltage	Vno	1	Rg = 600Ω	-	-94.5	-88	dBv	1
9	Channel Crosstalk	CT	1	Vout = -12.2dBv	30	50	-	dB	2
10	Ripple Rejection Ratio	RR	1	Vcc = 1.8V, fr = 100Hz Vr = -20dBv	64	72	-	dB	1
11	Muting Effect	MT	1	Vout = -12.2dBv	68	78	-	dB	2
12	Beep Output Voltage	Vbeep	1	Vbeep - in = 0dBv	-56	-51	-46	dBv	

Vcc = 2.4V, RL = 16Ω, Frequency = 1KHz, Rg = 10KΩ, Vbeep = 0V (GND), STB: OFF, MUTE: OFF, unless otherwise specified.

Note : 1) For this measurement, use the filter [ A-Curve ].  
2) For this measurement, use the filter [ 30KHz LPF ].

Eff. Date	Eff. Date	Eff. Date	Eff. Date	
9 Nov 2000				

Prepared		<b>Product Specifications</b> <b>AN17880A</b>	Ref No.	C-1
Checked			Total Page	7
Approved			Page No.	3

**Description of Test Circuits 1**

Test Circuit :

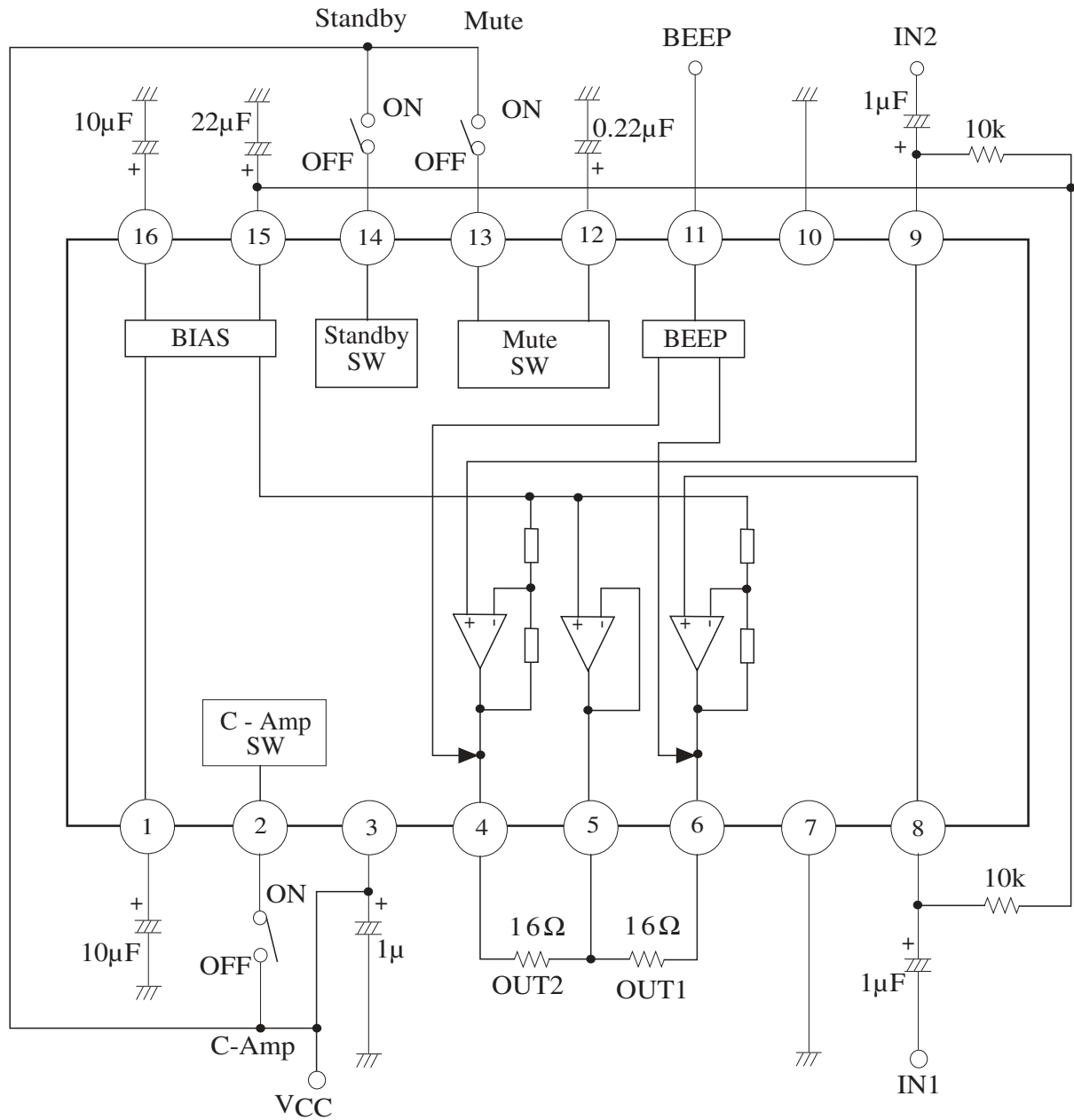

Note: The above circuit is used for Latchup testing.

Eff. Date	Eff. Date	Eff. Date	Eff. Date
9 Nov 2000			

### Circuit Function Block Diagram

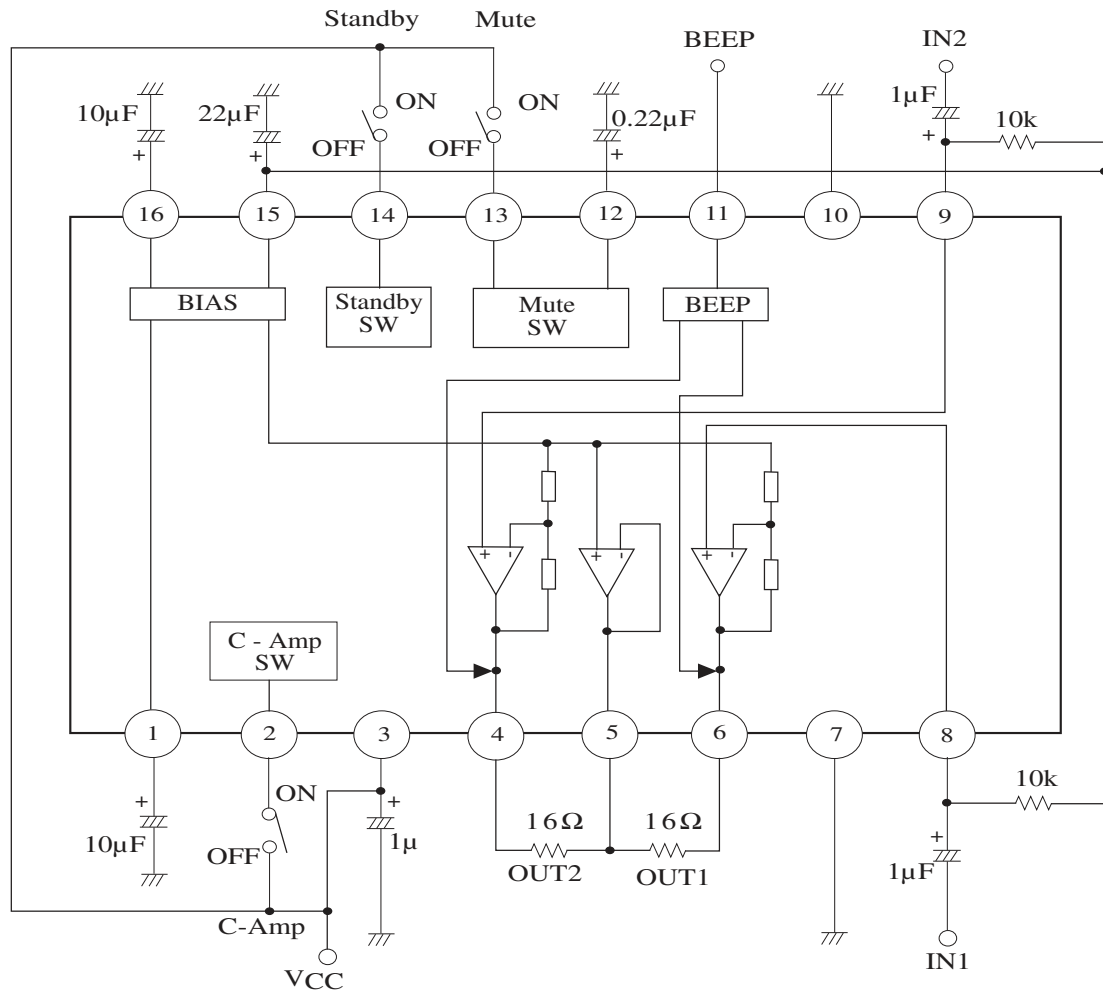

### Pin Descriptions

Pin No.	Pin Descriptions	Pin No.	Pin Descriptions
1	Ripple Filter	9	Ch.2 Input
2	Centre Amplifier Control	10	Input Gnd
3	Supply Voltage	11	Beep Input
4	Ch.2 Output	12	Mute time Control
5	Centre Amplifier Output	13	Mute Control
6	Ch.1 Output	14	Standby Control
7	Output Gnd	15	Bias Output
8	Ch.1 Input	16	Bias input

Eff. Date	Eff. Date	Eff. Date	Eff. Date
9 Nov 2000			

Prepared		<b>Product Specifications</b> <b>AN17880A</b>	Ref No.	E
Checked			Total Page	7
Approved			Page No.	5

Package Name	SSONF-16D
--------------	-----------

Unit : mm

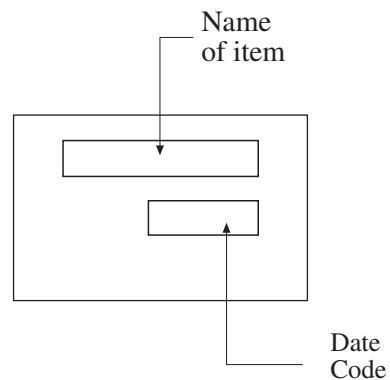
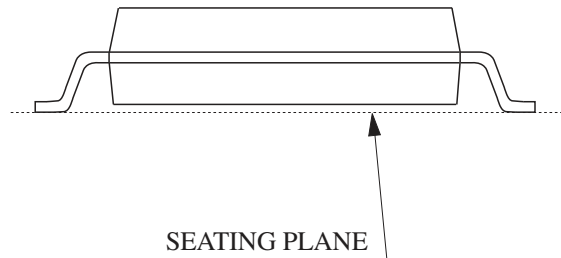
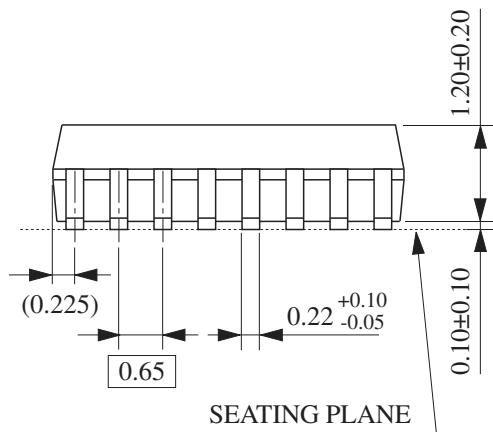
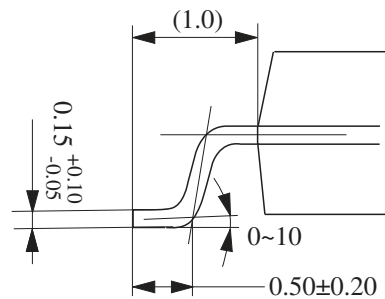
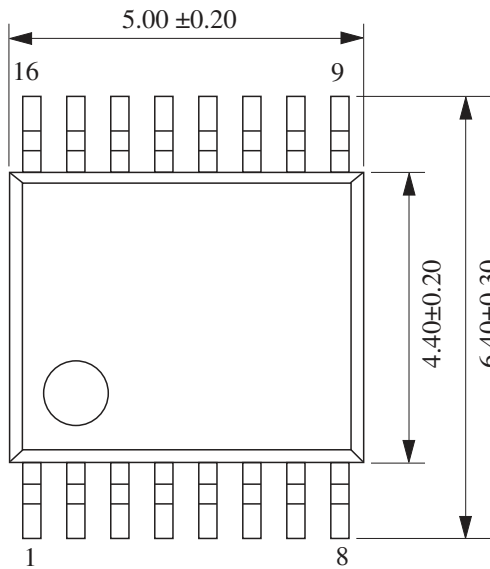

( ) : Reference Value

Eff. Date	Eff. Date	Eff. Date	Eff. Date
9 Nov 2000			

Prepared		<b>Product Specifications</b> <b>AN17880A</b>	Ref No.	F-1
Checked			Total Page	7
Approved			Page No.	6

(Structure Description)

Chip surface passivation	SiN,	PSG,	Others ( )	①
Lead frame material	Fe group,	Cu group,	Others ( )	②, ⑥
Inner lead surface process	Ag plating,	Au plating,	Others ( )	②
Outer lead surface process	Solder plating,	Solder dip,	Others ( )	⑥
Chip mounting method	Ag paste,	Au-Si alloy, Solder,	Others ( )	③
Wire bonding method	Thermalsonic bonding,		Others ( )	④
Wire material	Au,	Diameter : <u>24</u> μm	Others ( )	④
Mold material	Epoxy		Others ( )	⑤
Molding method	Transfer mold,	Multiplunger mold,	Others ( )	⑤

Package SSONF-16D

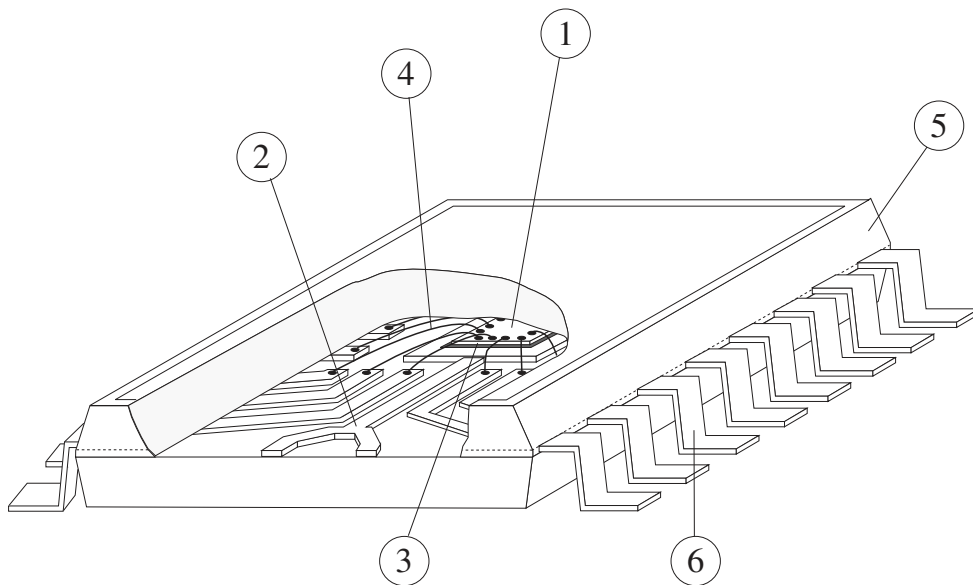

Eff. Date	Eff. Date	Eff. Date	Eff. Date	
9 Nov 2000				

Prepared		<b>Product Specifications</b> (Technical Data) <b>AN17880A</b>	Ref No.	G-1
Checked			Total Page	7
Approved			Page No.	7

### SSONF-16D Package Power Dissipation

$P_D - T_a$

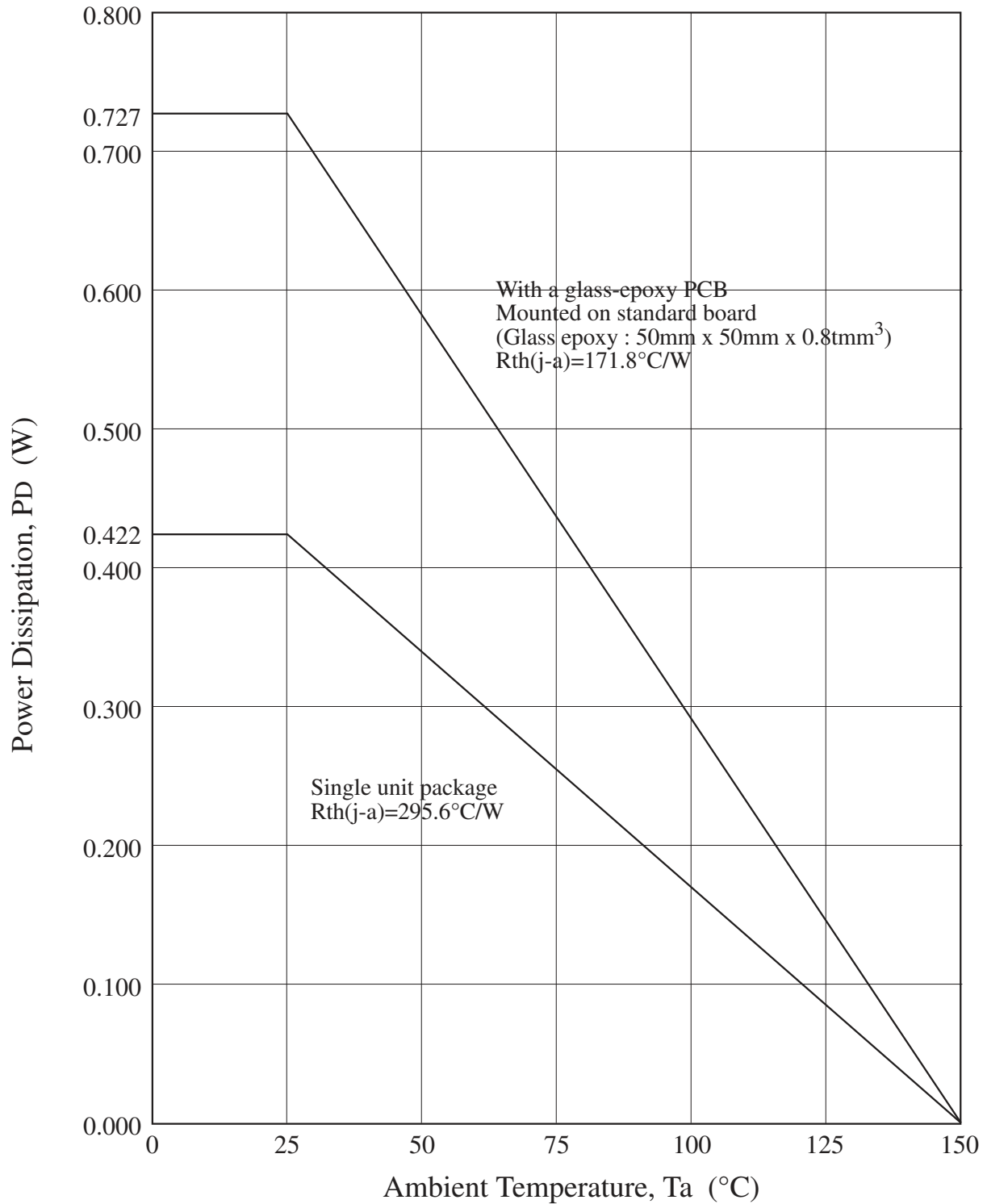

Eff. Date	Eff. Date	Eff. Date	Eff. Date
9 Nov 2000			