

## **Not Recommended for New Designs**

---

This product was manufactured for Maxim by an outside wafer foundry using a process that is no longer available. It is not recommended for new designs. The data sheet remains available for existing users.

A Maxim replacement or an industry second-source may be available. Please see the QuickView data sheet for this part or contact technical support for assistance.

For further information, [contact Maxim's Applications Tech Support](#).



# Ultra-Low Offset Voltage Operational Amplifier

**MAX400**

## General Description

The MAX400 guaranteed maximum 10 $\mu$ V offset error is the lowest input offset voltage of any commercially available (nonchopper) monolithic amplifier. The MAX400 represents a 2.5 times improvement over the highest grade OP07 (the OP07A), and a 5 times improvement over the best commercial temperature range device (OP07E). The offset voltage drift is guaranteed to be a maximum of 0.3 $\mu$ V/ $^{\circ}$ C which is also an improvement over the OP07 family.

For the ultimate in DC performance (5 $\mu$ V maximum offset voltage and 0.05 $\mu$ V/ $^{\circ}$ C maximum offset voltage drift) the MAX420 and MAX430 series of  $\pm$ 15V monolithic, chopper-stabilized amplifiers should be consulted.

## Applications

- Precision Amplifiers
- Thermocouple Amplifiers
- Low-Level Signal Processing
- Medical Instrumentation
- Strain Gauge Amplifiers
- High-Accuracy Data Acquisition

## Pin Configuration

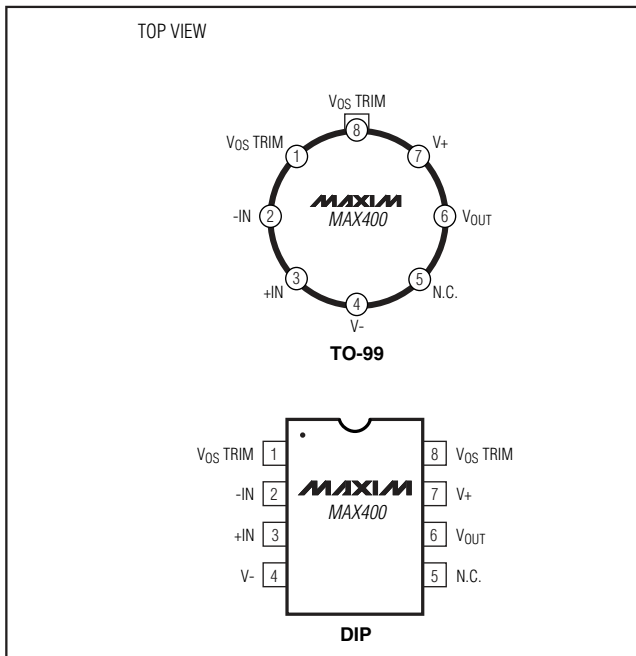

## Features

- ◆ Ultra-Low Offset Voltage: 10 $\mu$ V (max)
- ◆ Ultra-Low Offset Voltage Drift: 0.2 $\mu$ V/ $^{\circ}$ C
- ◆ Ultra Stable vs. Time: 0.2 $\mu$ V/month
- ◆ Ultra-Low Noise: 0.35 $\mu$ Vp-p
- ◆ Wide Supply Voltage:  $\pm$ 3V to  $\pm$ 18V
- ◆ High Common-Mode Input:  $\pm$ 14V
- ◆ No External Components Required
- ◆ Fits OP07, AD510, 725, 108A/308A Sockets

## Ordering Information

PART	TEMP RANGE	PIN-PACKAGE
MAX400MJA	-55 $^{\circ}$ C to +125 $^{\circ}$ C	8 CERDIP
MAX400MTV	-55 $^{\circ}$ C to +125 $^{\circ}$ C	8 TO-99
MAX400EJA	-40 $^{\circ}$ C to +85 $^{\circ}$ C	8 CERDIP
MAX400ETV	-40 $^{\circ}$ C to +85 $^{\circ}$ C	8 TO-99
MAX400CTV	0 $^{\circ}$ C to +70 $^{\circ}$ C	8 TO-99
MAX400CPA	0 $^{\circ}$ C to +70 $^{\circ}$ C	8 Plastic Dip
MAX400CSA	0 $^{\circ}$ C to +70 $^{\circ}$ C	8 SO

## Typical Operating Circuit

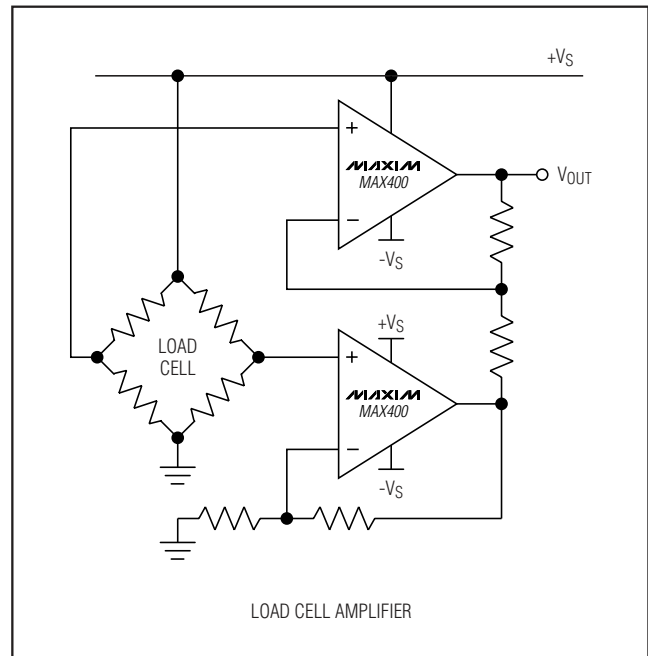

# Ultra-Low Offset Voltage Operational Amplifier

## ABSOLUTE MAXIMUM RATINGS

Total Supply Voltage (V+ to V-)	±22V
Internal Power Dissipation	500mW
TO-99 (T) (derate at 7.1mW/°C above +80°C)	
Hermetic Dip (J) (derate 6.7mW/°C above +75°C)	
Plastic Dip (P) (derate 5.6mW/°C above +36°C)	
Differential Input Voltage	±30V
Input Voltage (Note 1)	±22V
Storage Temperature Range	-65°C to +150°C

Operating Temperature Range	
MAX400M	-55°C to +125°C
MAX400E	-40°C to +85°C
MAX400C	0°C to +70°C
Lead Temperature (soldering, 10s)	+300°C
Duration of Output Short Circuit	Indefinite
Junction Temperature (T <sub>J</sub> )	-65°C to +160°C

**Note 1:** For supply voltages less than ±22V, the absolute maximum input voltage is equal to the supply voltage.

Stresses beyond those listed under "Absolute Maximum Ratings" may cause permanent damage to the device. These are stress ratings only, and functional operation of the device at these or any other conditions beyond those indicated in the operational sections of the specifications is not implied. Exposure to absolute maximum rating conditions for extended periods may affect device reliability.

## ELECTRICAL CHARACTERISTICS

(V<sub>S</sub> = ±15V, T<sub>A</sub> = +25°C, unless otherwise noted.)

PARAMETER	SYMBOL	CONDITIONS	MAX400M			MAX400C/E			UNITS
			MIN	TYP	MAX	MIN	TYP	MAX	
Input Offset Voltage	V <sub>OS</sub>	(Note 2)		4	10		10	15	μV
Long-Term Input Offset Voltage Stability	V <sub>OS/Time</sub>	(Note 3)		0.2			0.2		μV/month
Input Offset Current	I <sub>OS</sub>			0.3	2.0		0.3	2.0	nA
Input Bias Current	I <sub>B</sub>			±0.7	±2.0		±0.7	±2.0	nA
Input Noise Voltage	e <sub>N(P-P)</sub>	0.1Hz to 10Hz		0.35			0.35		μV <sub>P-P</sub>
Input Noise-Voltage Density	e <sub>N</sub>	f <sub>O</sub> = 10Hz		10.3			10.3		nV/√Hz
		f <sub>O</sub> = 100Hz		10.0			10.0		
		f <sub>O</sub> = 1000Hz		9.6			9.6		
Input Noise Current	I <sub>N(P-P)</sub>	0.1Hz to 10Hz		14			14		pA <sub>P-P</sub>
Input Noise-Current Density	I <sub>N</sub>	f <sub>O</sub> = 10Hz		0.32			0.32		pA/√Hz
		f <sub>O</sub> = 100Hz		0.14			0.14		
		f <sub>O</sub> = 1000Hz		0.12			0.12		
Input Resistance Differential Mode	R <sub>IN</sub>	(Note 4)	30	80		20	60		MΩ
Input Resistance Common Mode	R <sub>INCM</sub>			200			200		GΩ
Input Voltage Range	IVR		±13	±14		±13	±14		V
Common-Mode Rejection Ratio	CMRR	V <sub>CM</sub> = ±13V	114	126		114	126		dB
Power-Supply Rejection Ratio	PSRR	V <sub>S</sub> = ±3V to ±18V		4	10		4	10	μV/V
Large-Signal Voltage Gain	A <sub>VO</sub>	R <sub>L</sub> ≥ 2kΩ, V <sub>O</sub> = ±10V	500	1000		500	1000		V/mV
		R <sub>L</sub> ≥ 500Ω, V <sub>O</sub> = ±0.5V, V <sub>S</sub> = ±3V (Note 4)	150	400		150	400		

# Ultra-Low Offset Voltage Operational Amplifier

MAX400

## ELECTRICAL CHARACTERISTICS (continued)

( $V_S = \pm 15V$ ,  $T_A = +25^\circ C$ , unless otherwise noted.)

PARAMETER	SYMBOL	CONDITIONS	MAX400M			MAX400C/E			UNITS
			MIN	TYP	MAX	MIN	TYP	MAX	
Output Voltage Swing	$V_O$	$R_L \geq 10k\Omega$	$\pm 12.5$	$\pm 13.0$		$\pm 12.5$	$\pm 13.0$	V	
		$R_L \geq 2k\Omega$	$\pm 12.0$	$\pm 12.8$		$\pm 12.0$	$\pm 12.8$		
		$R_L \geq 1k\Omega$	$\pm 10.5$	$\pm 12.0$		$\pm 10.5$	$\pm 12.0$		
Slew Rate	SR	$R_L \geq 2k\Omega$		0.3			0.3	V/ $\mu S$	
Closed-Loop Bandwidth	BW	$A_{VCL} = +1V$		0.6			0.6	MHz	
Open-Loop Output Resistance	$R_O$	$V_O = 0V$ , $I_O = 0$		60			60	$\Omega$	
Power Consumption	$P_D$	$V_S = \pm 15V$ , no load		75	120		75	120	mW
		$V_S = \pm 3V$ , no load		4	6		4	6	
Offset Adjustment Range		$R_P = 20k\Omega$		$\pm 4$			$\pm 4$	mV	

**Note 2:**  $V_{OS}$  is measured one minute after application of power.

**Note 3:** Long-term Input Offset Voltage Stability refers to the average trend line of  $V_{OS}$  vs. Time over extended periods after the first 30 days of operation. Excluding the initial hour of operation, changes in  $V_{OS}$  during the first 30 operating days are typically 2.5 $\mu V$  – refer to typical performance curves.

**Note 4:** Guaranteed by design.

## ELECTRICAL CHARACTERISTICS

( $V_S = \pm 15V$ ,  $T_A =$  full operating temperature range, unless otherwise noted.)

PARAMETER	SYMBOL	CONDITIONS	MAX400M			MAX400C/E			UNITS
			MIN	TYP	MAX	MIN	TYP	MAX	
Input Offset Voltage	$V_{OS}$	(Note 5)		20	40		20	40	$\mu V$
Average Temperature Coefficient of Input Offset Voltage	$TCV_{OS}$	(Note 6)		0.2	0.3		0.2	0.3	$\mu V/^\circ C$
Input Offset Current	$I_{OS}$			0.8	4.0		0.8	4.0	nA
Average Input Offset Current Drift	$TCI_{OS}$			5			5		$pA/^\circ C$
Input Bias Current	$I_B$			$\pm 1.0$	$\pm 4.0$		$\pm 1.0$	$\pm 4.0$	nA
Average Input Bias Current Drift	$TCI_B$			8			8		$pA/^\circ C$
Input Voltage Range	IVC		$\pm 13$	$\pm 13.5$		$\pm 13$	$\pm 13.5$		V
Common-Mode Rejection Ratio	CMRR	$V_{CM} = \pm 13V$	106	123		106	123		dB
Power-Supply Rejection Ratio	PSRR	$V_S = \pm 3V$ to $\pm 18V$		5	20		5	20	$\mu V/V$
Large-Signal Voltage Gain	$A_{VO}$	$R_L \geq 2k\Omega$ , $V_O = \pm 10V$	200	400		200	400		V/mV
Output Voltage Swing	$V_D$	$R_L \geq 2k\Omega$	$\pm 12.0$	$\pm 12.6$		$\pm 12.0$	$\pm 12.6$		V

**Note 5:** Offset Voltage is measured one minute after application of power.

**Note 6:** 100% tested.

# Ultra-Low Offset Voltage Operational Amplifier

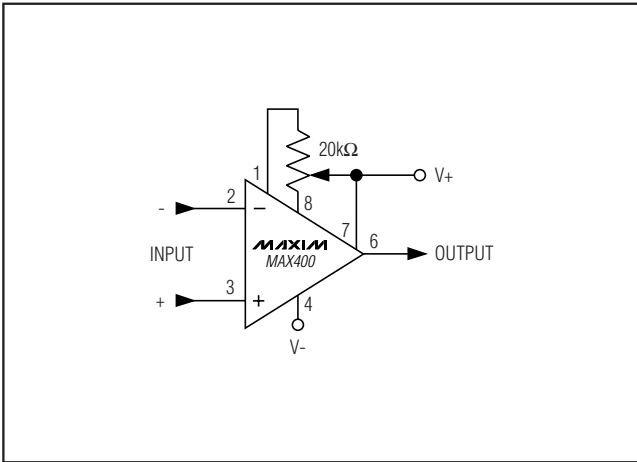

Figure 1. Optional Offset Nulling Circuit

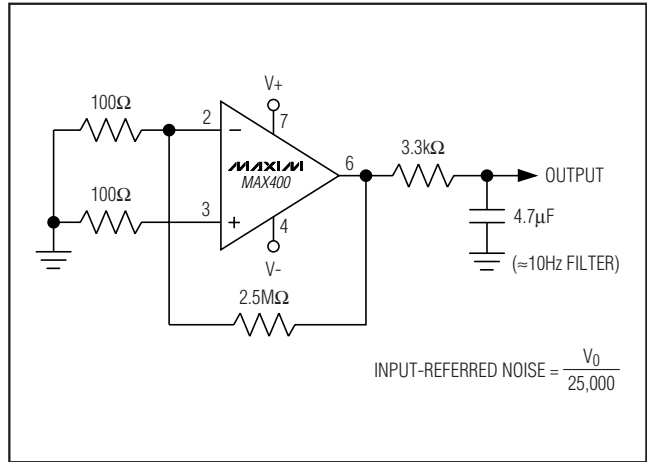
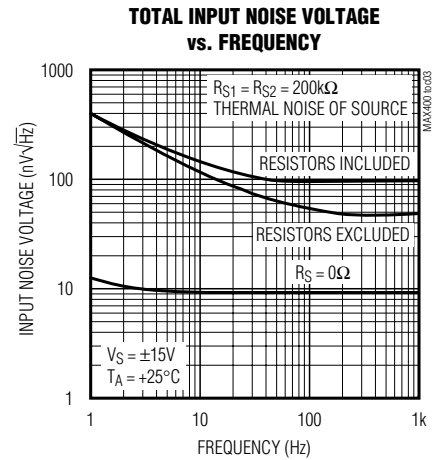
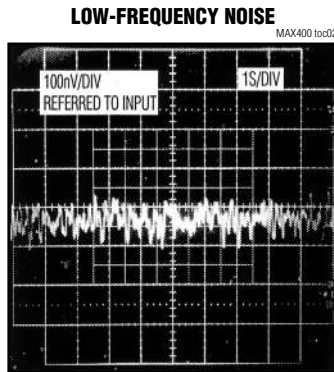
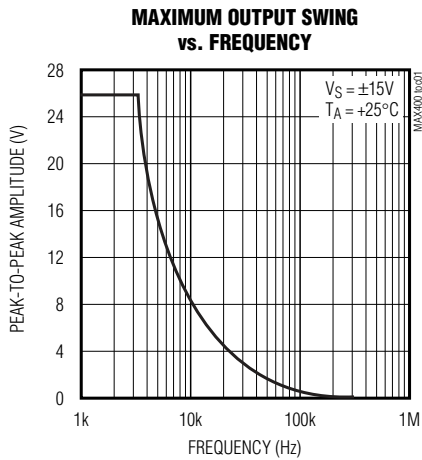

Figure 2. Low-Frequency Noise Test Circuit

## Typical Operating Characteristics



# Ultra-Low Offset Voltage Operational Amplifier

## Typical Operating Characteristics (continued)

**MAX400**

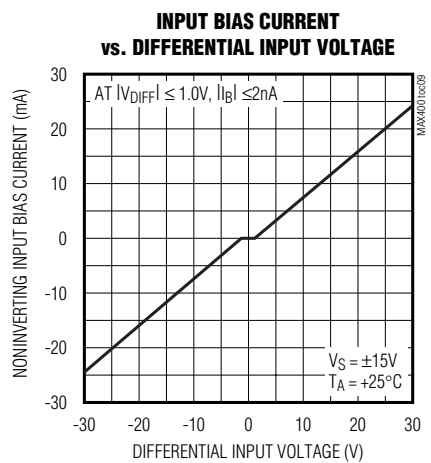
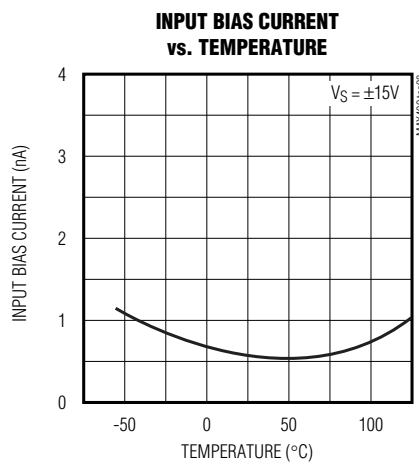
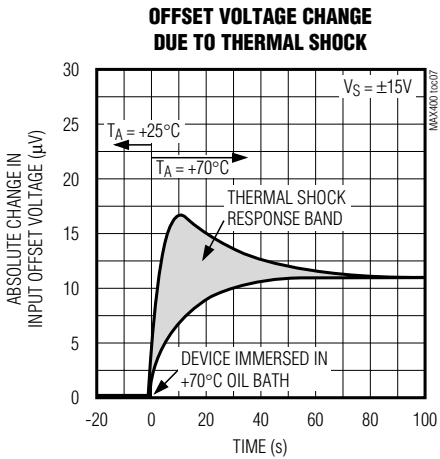
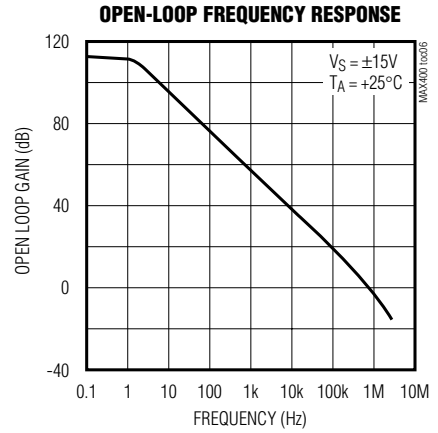
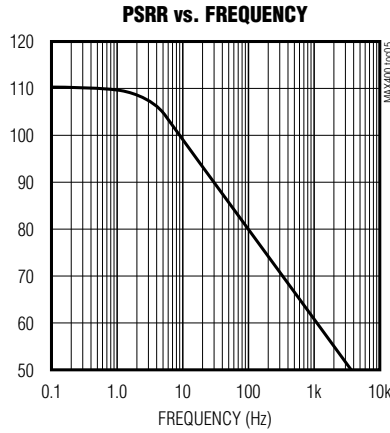
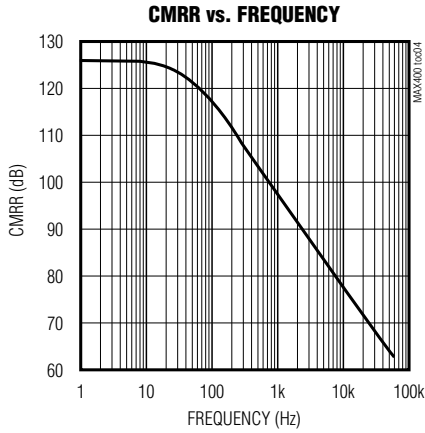

Maxim cannot assume responsibility for use of any circuitry other than circuitry entirely embodied in a Maxim product. No circuit patent licenses are implied. Maxim reserves the right to change the circuitry and specifications without notice at any time.

Maxim Integrated Products, 120 San Gabriel Drive, Sunnyvale, CA 94086 408-737-7600 \_\_\_\_\_ 5