

PART NUMBER	REVISION	DESCRIPTION	FEED TYPE
2150088-1	C	FINE CRIMP HEIGHT ADJUST	MECHANICAL
2150088-2	C	FINE CRIMP HEIGHT ADJUST	PNEUMATIC
7-2150088-1	C	MECHANICAL AND CRIMP TOOLING KIT	MECHANICAL
7-2150088-2	C	PNEUMATIC AND CRIMP TOOLING KIT	PNEUMATIC
7-2150088-7	A	CRIMP TOOLING KIT	-

ATLANTIC VERSION TERMINATOR INTERFACE ADAPTER

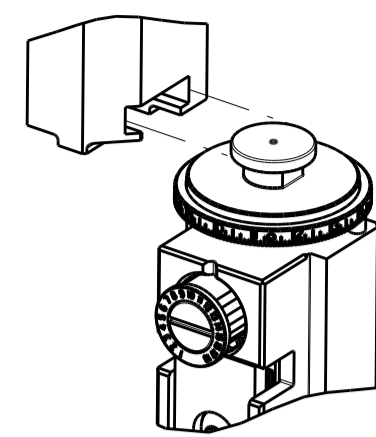

APPLICATOR DATA		
CRIMP	SIZE	TYPE
WIRE	2.79 mm [.110]	F
INSUL	4.57 mm [.180]	F

APPLICATOR INSTRUCTIONS 408-35043

TERMINAL DATA: TE TERMINAL TE CRIMP SPECIFICATION			
TERMINAL NAME: SHUR PLUG RECEPTACLE			
WIRE STRIP LENGTH	INSULATION DIAMETER RANGE		
5.00-6.00 mm [.197-.236 IN]	Ø2.54-3.68 mm [.100-.145 IN]		
TERMINAL APPLICATION SPECIFICATION	114-5208		
TERMINALS APPLIED			
TE TERMINAL	TE TERMINAL	TE TERMINAL	TE TERMINAL
170003-4	170003-6	1-170003-5	9-170003-5
170003-5	1-170003-4	2-170003-5	

TERMINAL DATA: TE TERMINAL TE CRIMP SPECIFICATION			
TERMINAL NAME: SHUR PLUG RECEPTACLE			
WIRE STRIP LENGTH	INSULATION DIAMETER RANGE		
5.00-6.00 mm [.197-.236 IN]	Ø2.54-3.68 mm [.100-.145 IN]		
TERMINAL APPLICATION SPECIFICATION			
TERMINALS APPLIED			
TE TERMINAL	TE TERMINAL	TE TERMINAL	TE TERMINAL
170003-4			

WIRE SIZE	CRIMP HEIGHT mm [INCH]	CRIMP HEIGHT REFERENCE SETTING
2.00mm2	1.73+/-0.05 [.068+/- .002]	7.8
1.25mm2	1.55+/-0.05 [.061+/- .002]	9.5
0.75mm2	1.42+/-0.05 [.056+/- .002]	11.0
0.50mm2	1.37+/-0.05 [.054+/- .002]	11.5

WIRE SIZE	CRIMP HEIGHT mm [INCH]	CRIMP HEIGHT REFERENCE SETTING
1.00mm2	1.49+/-0.05 [.059+/- .002]	10.2

- 1. RECOMMENDED SPARE PARTS
- 2. REFER TO SUPPLIED INSTRUCTION SHEET FOR CLEANING, LUBRICATION AND STORAGE OF APPLICATOR.
- 3. APPLY PART NUMBER 1-23419-5 LOCTITE TO THREADS OF ITEM 180. APPLY PART NUMBER 2-23419-6 LOCTITE TO THREADS OF ITEM 242.
- 4. CRIMP HEIGHT REFERENCE SETTING WAS THE SETTING USED WHEN THE APPLICATOR WAS QUALIFIED AT THE FACTORY. ADJUSTMENT MAY BE NECESSARY WHEN RUNNING APPLICATOR IN THE FIELD.
- 5. UNLESS SPECIFIED OTHERWISE TORQUE VALUES SHALL BE USED PER DOCUMENT, 101-35000.
- 6. THIS CRIMP PARAMETER IS PROVIDED TO MEET A CUSTOM AND UNIQUE CUSTOMER REQUIREMENT. IT HAS BEEN EVALUATED AND IS CONDITIONALLY SPECIFIED BY TE CONNECTIVITY. THIS CUSTOMIZED CRIMP PARAMETER IS NOT LISTED AS AN APPROVED APPLICATION WITHIN A TE CONNECTIVITY APPLICATION SPECIFICATION; HOWEVER, IT HAS BEEN VALIDATED ACCORDING TO **TE CONNECTIVITY SPECIFICATIONS 109-18079(TEST GROUP 1) AND 114-18022. TE CONNECTIVITY EXPRESSLY DISCLAIMS ANY AND ALL WARRANTIES THAT THE PRODUCT WILL PERFORM SIMILARLY TO VALIDATED AND APPROVED APPLICATIONS, AS STATED WITHIN TE CONNECTIVITY APPLICATION SPECIFICATIONS, INCLUDING BUT NOT LIMITED TO IMPLIED WARRANTIES OF MERCHANTABILITY OR FITNESS FOR PARTICULAR PURPOSE.** AS SUCH, IT IS HIGHLY RECOMMENDED THAT THE CUSTOMER PERFORM FURTHER DETAILED EVALUATION TO ASSESS PRODUCT PERFORMANCE IN THE SPECIFIC APPLICATION.

***WARNING**
ON INSTALLATION, SET WIRE DISC TO CRIMP HEIGHT REFERENCE SETTING FOR LARGEST WIRE SIZE. CRIMP HEIGHT REFERENCE SETTINGS GREATER THAN THE VALUE SHOWN MAY CAUSE DAMAGE TO THE CRIMP TOOLING, REFER TO THE INSTRUCTION SHEET FOR PROPER SETUP AND ADJUSTMENTS.

ATLANTIC VERSION
Shown on sheets 1 of 4 & 2 of 4
(Pacific version shown on sheets 3 of 4 & 4 of 4)

LOC	DIST	REVISIONS					
		P	LTN	DESCRIPTION	DATE	OWN	APVD
A	66	B1		ECR-16-014016	03OCT2016	MR	JDG
		C		ECR-19-000067	03JAN2019	FL	CT

-	1	-	1	-	2119640-1	PUSH ROD, AIR FEED	250	
-	1	-	1	-	1803259-1	BUSHING, FLANGED	249	
-	1	-	1	-	2119641-1	FEED CAM, AIR FEED	248	
-	1	1	1	1	2119082-9	CAM, SNAIL, INSULATION ADJUSTMENT	244	
-	1	1	1	1	2079764-1	WASHER, WAVE SPRING, CREST-TO-CREST	243	
-	1	1	1	1	2119083-1	RETAINER, INSULATION DIAL	242	
-	-	1	-	1	2119580-1	MECHANICAL FEED ASSEMBLY	239	
-	1	-	1	-	2063440-1	AIR FEED MODULE	238	
-	1	1	1	1	1-18028-0	WASHER, FLAT, REG M8	192	
-	1	1	1	1	1-1976055-8	STANDOFF, HOLD-DOWN	180	
-	1	1	1	1	6-993111-6	PIN, SLOTTED SPRING 3.0 X 14.0	177	
-	1	1	1	1	8-22280-7	SPRING, COMPRESSION	176	
-	1	1	1	1	1752353-2	GUIDE PIN,HOLDDOWN	175	
-	1	1	1	1	1901680-2	GUIDE PIN,HOLDDOWN	174	
-	2	-	2	-	21045-3	RING, RETAIN, EXTERN, 3/16 CRESCENT	172	
-	REF	REF	REF	REF	994970-2	COUNTER, MAGNETIC	164	
-	1	-	1	-	240638-1	SPRING, FEED FINGER	163	
-	1	-	1	-	3-23627-7	PIN, RETAIN, GRVD, 3/16 X .854	137	
-	1	1	1	1	455888-5	SPACER, CRIMPER	82	
-	1	1	1	1	2119791-5	DEPRESSOR, WIRE	73	
-	1	1	1	1	1803607-2	DOCUMENTATION PACKAGE	71	
-	2	2	2	2	2-18032-2	SCR, SET, FLT PNT, M3 X 10.0	70	
-	2	2	2	2	2119943-1	WASHER, SPACER	69	
-	1	1	1	1	2119740-1	TAG, IDENTIFICATION	67	
-	2	2	2	2	2168078-1	SCREW, DRIVE, RH, RoHS, 2 x .188	66	
-	1	1	1	1	1901681-5	HOLDDOWN, TERMINAL	65	
-	1	1	1	1	2168083-2	SCR, SKT HD CAP, RoHS, M4 X 8.0	60	
-	-	1	-	1	5-18022-5	SCR, HEX HD CAP, M4 X 6.0	59	
-	-	1	-	1	2063961-1	FEED FINGER	58	
-	4	4	4	4	2168400-4	SHCS, LOW HEAD, RoHS, M4 X 8	57	
-	2	2	2	2	1-2168083-0	SCR, SKT HD CAP, RoHS, M4 X 10	56	
-	2	2	2	2	5018030-1	NUT, HEX, REG, RoHS, M3	54	
-	2	2	2	2	986965-8	NUT, LOCK, HEX, TORQUE (M4)	53	
-	1	1	1	1	1-5018030-0	NUT, HEX, REG, RoHS, M3.5	52	
-	1	-	1	-	2119792-2	PAWL, EF, AIR	51	
-	1	2	1	2	18023-9	SCR, SKT HD CAP M4 X 6.0	49	
-	-	1	-	1	2119652-1	FEED CAM, PRE FEED	48	
-	-	1	-	1	2119653-1	FEED CAM, POST FEED	47	
-	1	1	1	1	2119655-5	APPLICATOR BASIC ASSEMBLY, EF	46	
-	1	1	1	1	1803517-1	RAM ASSEMBLY, EF ATLANTIC	44	
-	1	1	1	1	1803602-1	SCR, BHSC, RoHS (M8 X 25)	41	
-	8	8	8	8	1-18028-2	WASHER, FLAT, REG M4	33	
-	2	2	2	2	2168083-9	SCR, SKT HD CAP, RoHS, M4 X 20	31	
-	2	2	2	2	2168083-2	SCR, SKT HD CAP, RoHS, M4 X 8.0	29	
-	1	1	1	1	240639-1	STRIPPER (MACHINING)	27	
-	2	2	2	2	1-2168083-5	SCR, SKT HD CAP, RoHS, M4 X 30	25	
-	1	1	1	1	1752371-5	PLATE, STRIP GUIDE	24	
-	2	2	2	2	2-22281-3	SPRING, COMPRESSION	22	
-	1	1	1	1	1803292-4	DRAG	20	
-	2	2	2	2	1901259-6	GUIDE, LOWER STRIP	18	
-	4	4	4	4	1-2079383-1	SCR, BHSC, RoHS (M6 X 12)	17	
-	1	1	1	1	1752360-1	SPACER,HOLD-DOWN	13	
-	1	1	1	1	240644-1	PLATE, REAR SHEAR	11	
-	1	1	1	1	690482-4	PLATE, FRONT SHEAR	9	
-	1	2	2	1	1	1803001-7	ANVIL, COMBINATION, END FEED	8
-	1	1	1	1	1	1-690474-7	BLADE, SLUG	7
-	1	1	1	1	1	2-240641-9	SPACER	5
-	1	1	1	1	1	238011-4	BLOCK, CRIMPER SPACER	4
-	1	2	2	1	1	2-1633961-7	CRIMPER, INSULATION F PREMIUM	3
-	1	1	1	1	1	455888-6	SPACER, CRIMPER	2
-	1	2	2	1	1	456408-2	CRIMPER, WIRE PREMIUM	1
-	77	72	71	2	-1	PART NO	DESCRIPTION	ITEM NO

DIMENSIONS:		TOLERANCES UNLESS OTHERWISE SPECIFIED:		DRAWN: Y. YIN 23FEB2012		CHK: G. BAILEY 23FEB2012		APVD: S. XI 23FEB2012		NAME: Ocean End Feed Applicator	
mm		0 PLC ±		PRODUCT SPEC		APPLICATION SPEC		SIZE: A1		CAGE CODE: 00779	
MATERIAL:		FINISH:		WEIGHT:		SCALE: 1:1		SHEET: 1 of 4		REV: C	

LOC	DIST	REV	DATE	BY	APPV
A	66				
REVISIONS			DESCRIPTION	DATE	BY
-			SEE SHEET 1	-	-

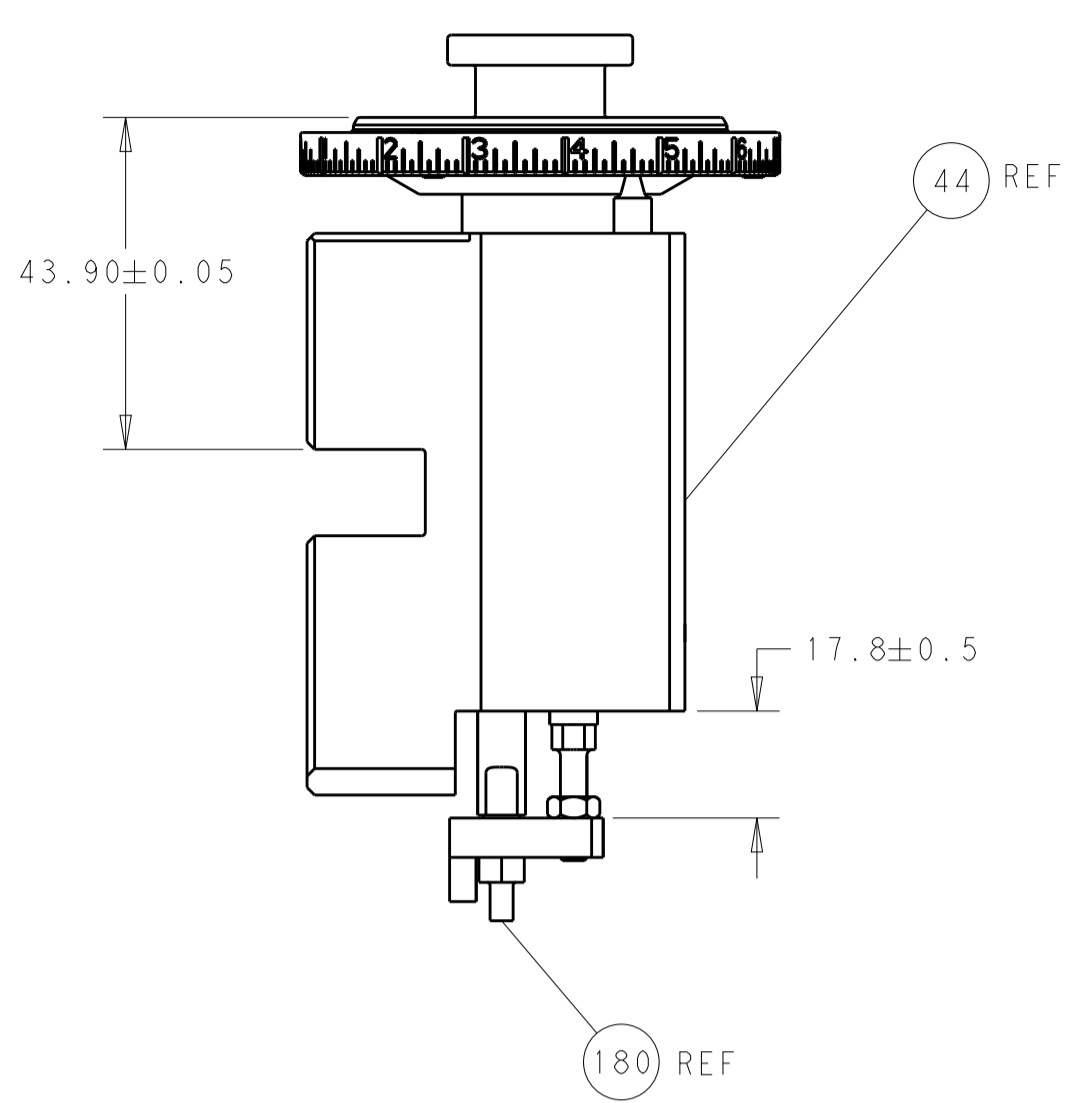

RAM AND HOLDDOWN SET-UP

FEED TYPE
MECHANICAL

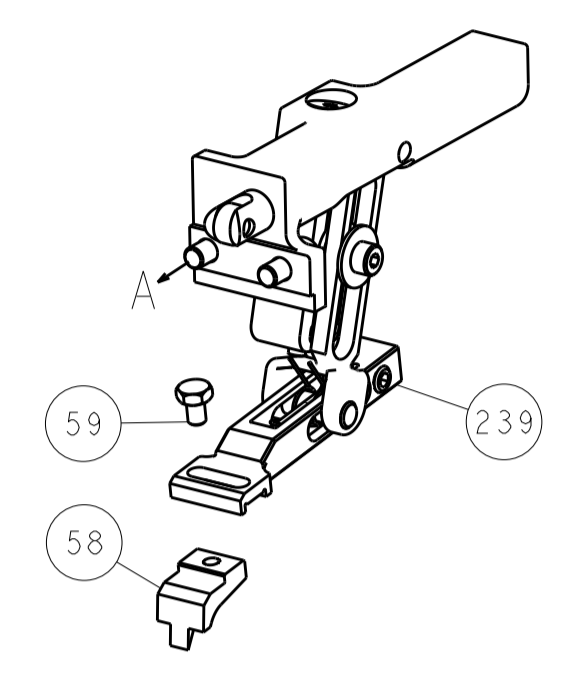

PNEUMATIC

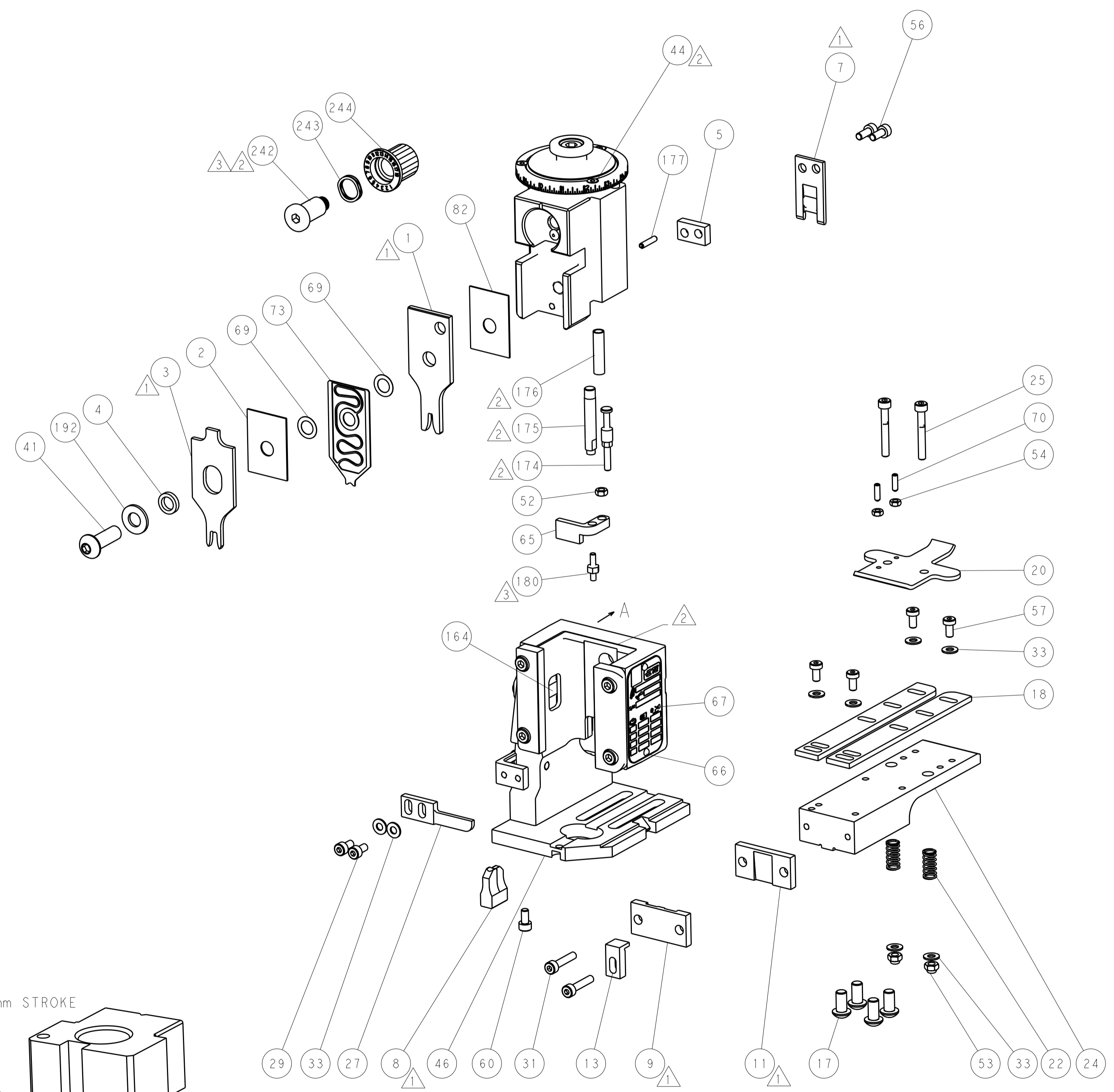
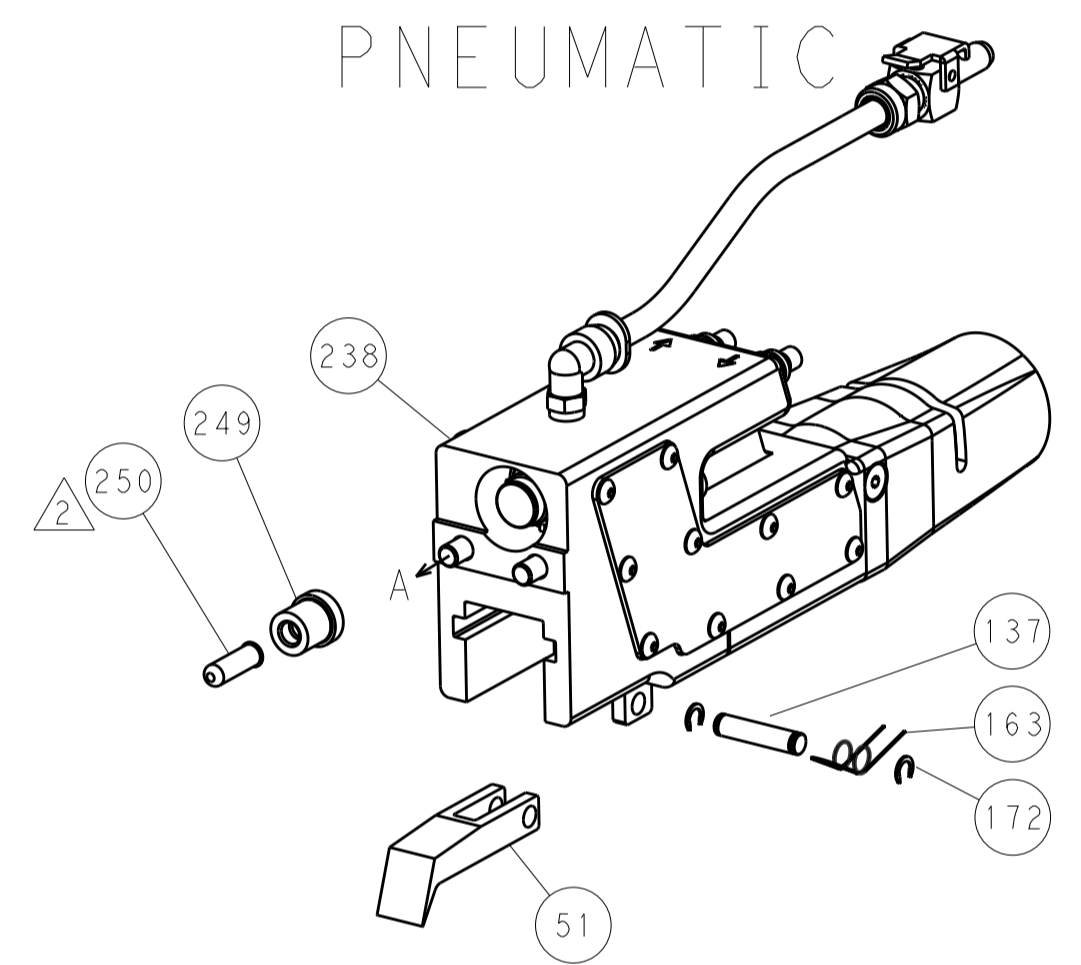

CAM POSITIONS

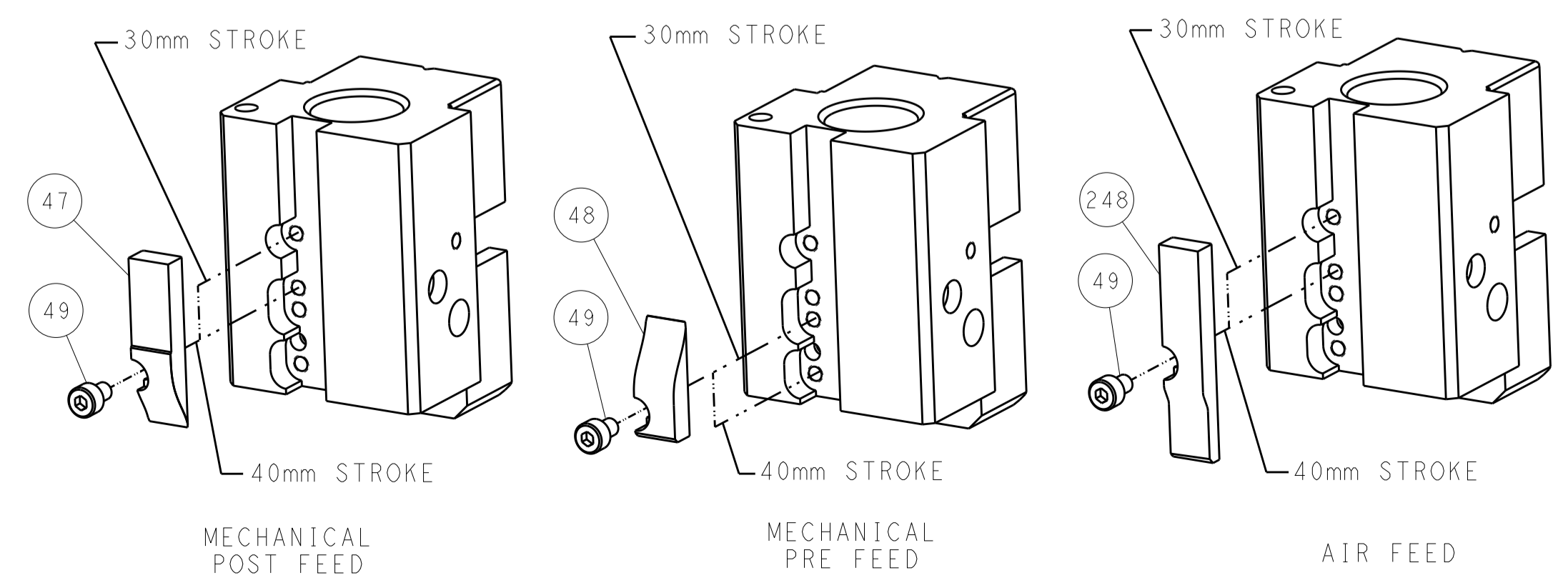

ATLANTIC VERSION
 Shown on sheets 1 of 4 & 2 of 4
 (Pacific version shown on sheets 3 of 4 & 4 of 4)

DIMENSIONS:		TOLERANCES UNLESS OTHERWISE SPECIFIED:		DWG: Y. YIN 23FEB2012		TE Connectivity	
mm		0 PLC ±		CHK: G. BAILEY 23FEB2012		Harrisburg, PA 17105-3608	
Ø		1 PLC ±		APVD: S. XI 23FEB2012		NAME: Ocean End Feed Applicator	
H		2 PLC ±		PRODUCT SPEC		SIZE: CAGE CODE DRAWING NO	
L		3 PLC ±		APPLICATION SPEC		RESTRICTED TO	
R		4 PLC ±		WEIGHT		A1 00779 ©=2150088	
S		5 PLC ±		MATERIAL		Customer Accessible Production Drawing	
T		6 PLC ±		FINISH		SCALE: 1:1 SHEET 2 OF 4 REV C	
U		7 PLC ±				SHEETS 3 & 4 ARE NOT REQUIRED FOR ATLANTIC VERSION	

PART NUMBER	REVISION	DESCRIPTION	FEED TYPE
2-2150088-1	C	FINE CRIMP HEIGHT ADJUST	MECHANICAL
2-2150088-2	C	FINE CRIMP HEIGHT ADJUST	PNEUMATIC
7-2150088-7	A	CRIMP TOOLING KIT	-

PACIFIC VERSION TERMINATOR
INTERFACE ADAPTER

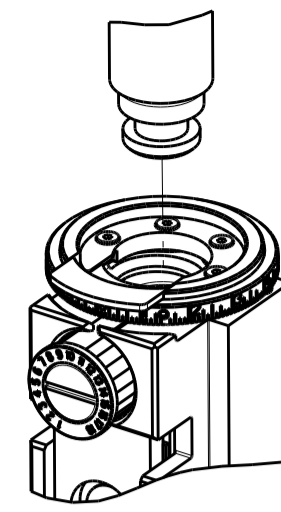

APPLICATOR DATA		
CRIMP	SIZE	TYPE
WIRE	2.79 mm (.110)	F
INSUL	4.57 mm (.180)	F
APPLICATOR INSTRUCTIONS 408-35043		

TERMINAL DATA: TE TERMINAL TE CRIMP SPECIFICATION			
TERMINAL NAME: SHUR PLUG RECEPTACLE			
WIRE STRIP LENGTH	INSULATION DIAMETER RANGE		
5.00-6.00 mm (.197-.236 IN)	Ø2.54-3.68 mm (.100-.145 IN)		
TERMINAL APPLICATION SPECIFICATION	114-5208	-	-
TERMINALS APPLIED			
TE TERMINAL	TE TERMINAL	TE TERMINAL	TE TERMINAL
170003-4	170003-6	1-170003-5	9-170003-5
170003-5	1-170003-4	2-170003-5	

TERMINAL DATA: TE TERMINAL TE CRIMP SPECIFICATION			
TERMINAL NAME: SHUR PLUG RECEPTACLE			
WIRE STRIP LENGTH	INSULATION DIAMETER RANGE		
5.00-6.00 mm (.197-.236 IN)	Ø2.54-3.68 mm (.100-.145 IN)		
TERMINAL APPLICATION SPECIFICATION		-	-
TERMINALS APPLIED			
TE TERMINAL	TE TERMINAL	TE TERMINAL	TE TERMINAL
170003-4			

WIRE SIZE	CRIMP HEIGHT mm [INCH]	CRIMP HEIGHT REFERENCE SETTING
2.00mm2	1.73+/-0.05 [.068+/- .002]	7.8
1.25mm2	1.55+/-0.05 [.061+/- .002]	9.5
0.75mm2	1.42+/-0.05 [.056+/- .002]	11.0
0.50mm2	1.37+/-0.05 [.054+/- .002]	11.5

WIRE SIZE	CRIMP HEIGHT mm [INCH]	CRIMP HEIGHT REFERENCE SETTING
1.00mm2	1.49+/-0.05 [.059+/- .002]	10.2

- 1 RECOMMENDED SPARE PARTS
- 2 REFER TO SUPPLIED INSTRUCTION SHEET FOR CLEANING, LUBRICATION AND STORAGE OF APPLICATOR.
- 3 APPLY PART NUMBER 1-23419-5 LOCTITE TO THREADS OF ITEM 180. APPLY PART NUMBER 2-23419-6 LOCTITE TO THREADS OF ITEM 242.
- 4 CRIMP HEIGHT REFERENCE SETTING WAS THE SETTING USED WHEN THE APPLICATOR WAS QUALIFIED AT THE FACTORY. ADJUSTMENT MAY BE NECESSARY WHEN RUNNING APPLICATOR IN THE FIELD.
- 5. UNLESS SPECIFIED OTHERWISE TORQUE VALUES SHALL BE USED PER DOCUMENT, 101-35000.
- 6 THIS CRIMP PARAMETER IS PROVIDED TO MEET A CUSTOM AND UNIQUE CUSTOMER REQUIREMENT. IT HAS BEEN EVALUATED AND IS CONDITIONALLY SPECIFIED BY TE CONNECTIVITY. THIS CUSTOMIZED CRIMP PARAMETER IS NOT LISTED AS AN APPROVED APPLICATION WITHIN A TE CONNECTIVITY APPLICATION SPECIFICATION; HOWEVER, IT HAS BEEN VALIDATED ACCORDING TO **TE CONNECTIVITY SPECIFICATIONS 109-18079 (TEST GROUP 1) AND 114-18022. TE CONNECTIVITY EXPRESSLY DISCLAIMS ANY AND ALL WARRANTIES THAT THE PRODUCT WILL PERFORM SIMILARLY TO VALIDATED AND APPROVED APPLICATIONS, AS STATED WITHIN TE CONNECTIVITY APPLICATION SPECIFICATIONS, INCLUDING BUT NOT LIMITED TO IMPLIED WARRANTIES OF MERCHANTABILITY OR FITNESS FOR PARTICULAR PURPOSE.** AS SUCH, IT IS HIGHLY RECOMMENDED THAT THE CUSTOMER PERFORM FURTHER DETAILED EVALUATION TO ASSESS PRODUCT PERFORMANCE IN THE SPECIFIC APPLICATION.

***WARNING**
ON INSTALLATION, SET WIRE DISC TO CRIMP HEIGHT REFERENCE SETTING FOR LARGEST WIRE SIZE. CRIMP HEIGHT REFERENCE SETTINGS GREATER THAN THE VALUE SHOWN MAY CAUSE DAMAGE TO THE CRIMP TOOLING, REFER TO THE INSTRUCTION SHEET FOR PROPER SETUP AND ADJUSTMENTS.

PACIFIC VERSION
Shown on sheets 3 of 4 & 4 of 4
(Atlantic version shown on sheets 1 of 4 & 2 of 4)

LOC	DIST	REVISIONS				
		P	LTN	DATE	OWN	APVD
A	66	-	SEE SHEET 1	-	-	-

-	1	1	2119640-1	PUSH ROD, AIR FEED	250
-	1	1	1803259-1	BUSHING, FLANGED	249
-	1	1	2119082-9	CAM, SNAIL, INSULATION ADJUSTMENT	244
-	1	1	2079764-1	WASHER, WAVE SPRING, CREST-TO-CREST	243
3	-	1	2119083-1	RETAINER, INSULATION DIAL	242
-	-	1	2119580-1	MECHANICAL FEED ASSEMBLY	239
-	1	-	2063440-1	AIR FEED MODULE	238
-	1	1	1-18028-0	WASHER, FLAT, REG M8	192
-	4	4	2079383-9	SCR, BHSC, RoHS (M6 X 20)	186
3	-	1	1-1976055-8	STANDOFF, HOLD-DOWN	180
-	1	1	6-993111-6	PIN, SLOTTED SPRING 3.0 X 14.0	177
-	1	1	8-22280-7	SPRING, COMPRESSION	176
-	1	1	1752353-2	GUIDE PIN, HOLDDOWN	175
-	1	1	1901680-2	GUIDE PIN, HOLDDOWN	174
-	2	2	21045-3	RING, RETAIN, EXTERN, 3/16 CRESCENT	172
-	REF	REF	994970-2	COUNTER, MAGNETIC	164
-	1	1	240638-1	SPRING, FEED FINGER	163
-	1	-	2119641-2	FEED CAM, AIR FEED	152
-	1	1	2168083-8	SCR, SKT HD CAP, RoHS, M4 X 16	144
-	-	1	2119653-2	FEED CAM, POST FEED	142
-	1	1	2119655-6	APPLICATOR BASIC ASSEMBLY, EF	141
-	1	1	1803518-1	RAM ASSEMBLY, EF PACIFIC	140
-	1	1	3-23627-7	PIN, RETAIN, GRVD, 3/16 X .854	137
-	1	1	455888-5	SPACER, CRIMPER	82
-	1	1	2119791-5	DEPRESSOR, WIRE	73
-	1	1	1803607-2	DOCUMENTATION PACKAGE	71
-	2	2	2-18032-2	SCR, SET, FLT PNT, M3 X 10.0	70
-	2	2	2119943-1	WASHER, SPACER	69
-	1	1	2119740-1	TAG, IDENTIFICATION	67
-	2	2	2168078-1	SCREW, DRIVE, RH, RoHS, 2 x .188	66
-	1	1	1901681-5	HOLDDOWN, TERMINAL	65
-	1	1	5-18022-5	SCR, HEX HD CAP, M4 X 6.0	59
-	-	1	2063961-1	FEED FINGER	58
-	4	4	2168400-4	SHCS, LOW HEAD, RoHS, M4 X 8	57
-	2	2	1-2168083-0	SCR, SKT HD CAP, RoHS, M4 X 10	56
-	2	2	5018030-1	NUT, HEX, REG, RoHS, M3	54
-	2	2	986965-8	NUT, LOCK, HEX, TORQUE (M4)	53
-	1	1	1-5018030-0	NUT, HEX, REG, RoHS, M3.5	52
-	1	-	2119792-2	PAWL, EF, AIR	51
-	1	2	18023-9	SCR, SKT HD CAP M4 X 6.0	49
-	-	1	2119652-1	FEED CAM, PRE FEED	48
-	1	1	1803602-1	SCR, BHSC, RoHS (M8 X 25)	41
-	8	8	1-18028-2	WASHER, FLAT, REG M4	33
-	2	2	2168083-9	SCR, SKT HD CAP, RoHS, M4 X 20	31
-	2	2	2168083-2	SCR, SKT HD CAP, RoHS, M4 X 8.0	29
-	1	1	240639-1	STRIPPER (MACHINING)	27
-	2	2	1-2168083-5	SCR, SKT HD CAP, RoHS, M4 X 30	25
-	1	1	1752371-5	PLATE, STRIP GUIDE	24
-	2	2	2-22281-3	SPRING, COMPRESSION	22
-	1	1	1803292-4	DRAG	20
-	2	2	1901259-6	GUIDE, LOWER STRIP	18
-	1	1	1752360-1	SPACER, HOLD-DOWN	13
1	-	1	240644-1	PLATE, REAR SHEAR	11
1	-	1	690482-4	PLATE, FRONT SHEAR	9
1	1	1	1803001-7	ANVIL, COMBINATION, END FEED	8
1	-	1	1-690474-7	BLADE, SLUG	7
1	-	1	2-240641-9	SPACER	5
-	1	1	238011-4	BLOCK, CRIMPER SPACER	4
1	1	1	2-1633961-7	CRIMPER, INSULATION F PREMIUM	3
-	1	1	455888-6	SPACER, CRIMPER	2
1	1	1	456408-2	CRIMPER, WIRE PREMIUM	1
-	77-22-21		PART NO	DESCRIPTION	ITEM NO

DIMENSIONS:		TOLERANCES UNLESS OTHERWISE SPECIFIED:		DWN		23FEB2012		TE Connectivity	
mm		0 PLC ±		Y. YIN		23FEB2012		Harrisburg, PA 17105-3608	
Ø		1 PLC ±		CHK		G. BAILEY		NAME	
H		2 PLC ±		S. XI		23FEB2012		Ocean End Feed	
L		3 PLC ±		APVD				Applicator	
R		4 PLC ±		S. XI				SIZE	
ANGLES		FINISH		WEIGHT		A1		CAGE CODE	
								DRAWING NO	
								00779	
								©=2150088	
								RESTRICTED TO	
								Customer Accessible Production Drawing	
								SCALE	
								1:1	
								SHEET	
								3 OF 4	
								REV	
								C	

LOC	DIST	REV	DATE	BY	APPV
A	66				
REVISIONS			DESCRIPTION	DATE	BY
-			SEE SHEET 1	-	-

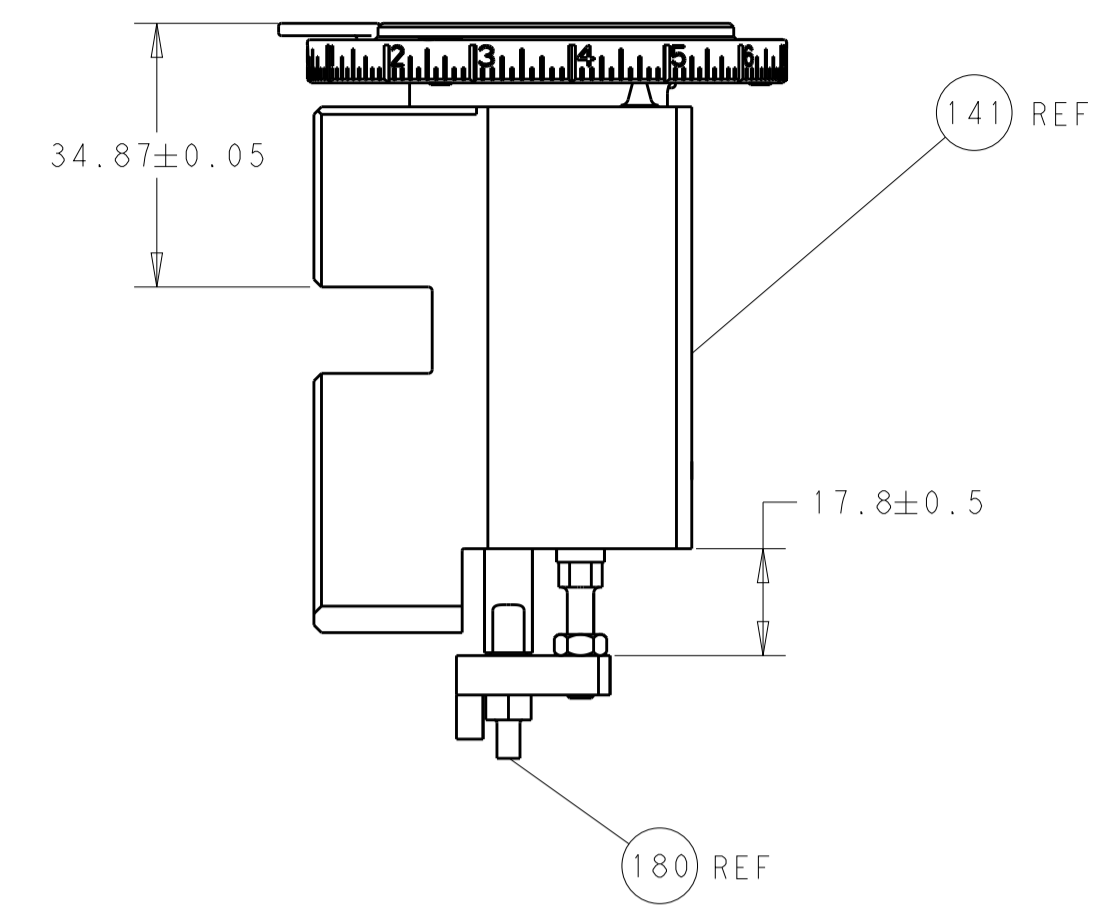

RAM AND HOLDDOWN SET-UP

FEED TYPE
MECHANICAL

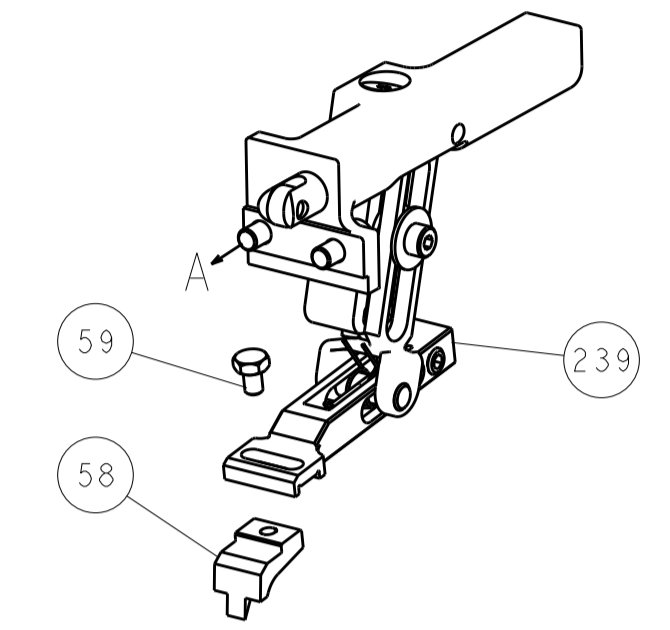

PNEUMATIC

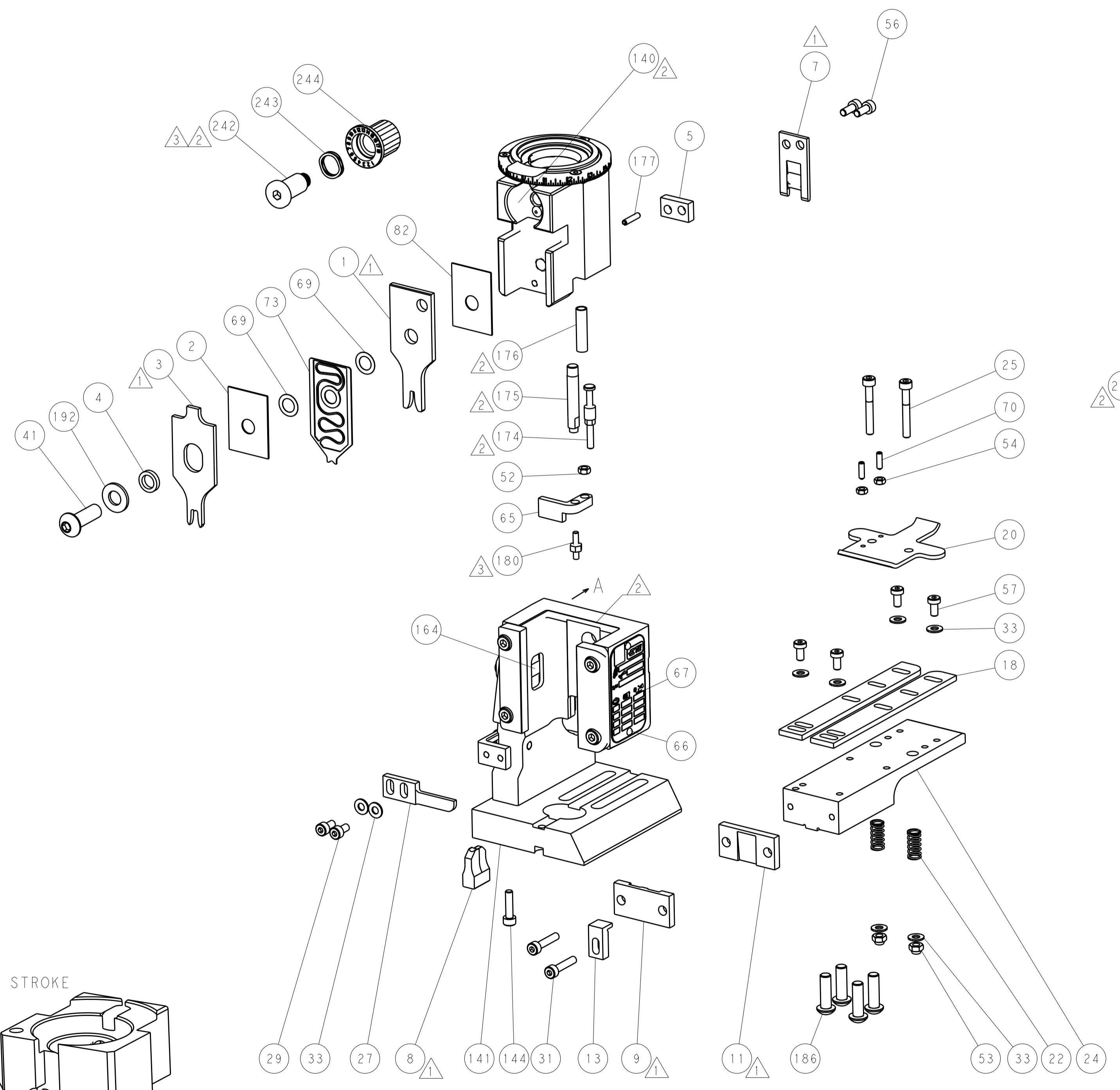
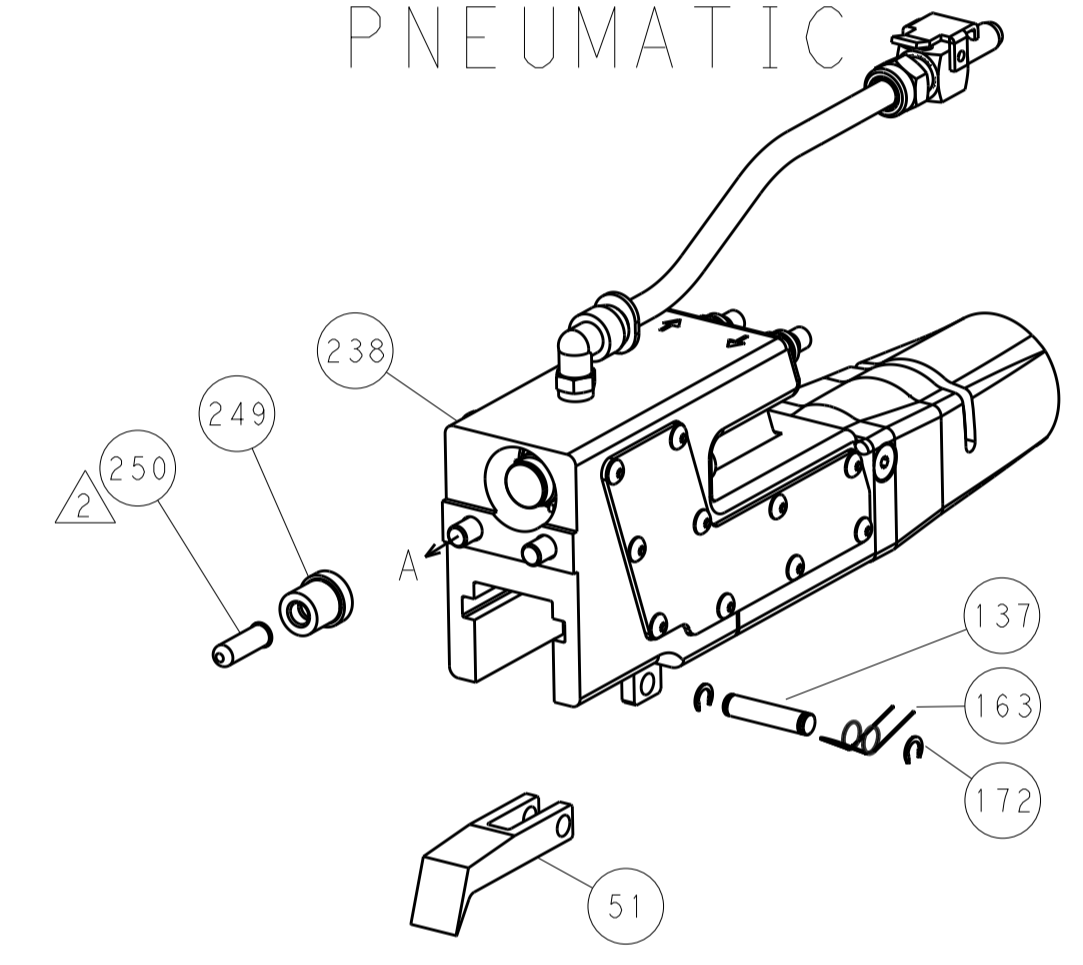

CAM POSITIONS

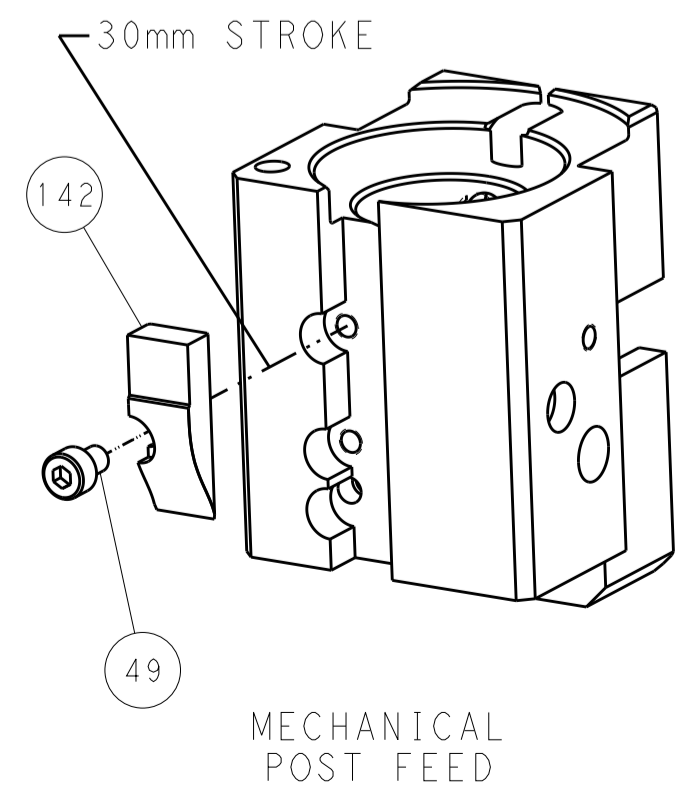

MECHANICAL POST FEED

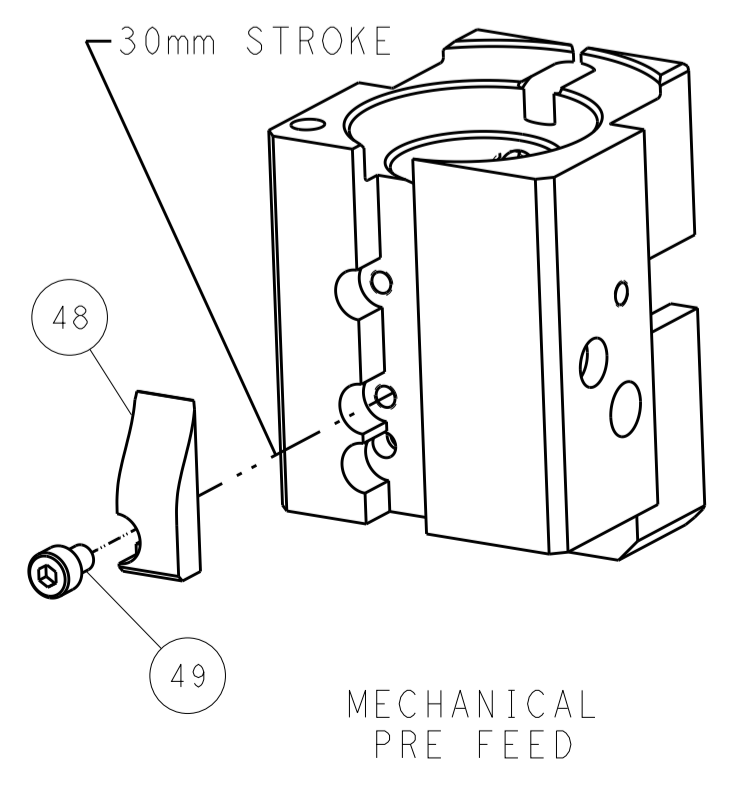

MECHANICAL PRE FEED

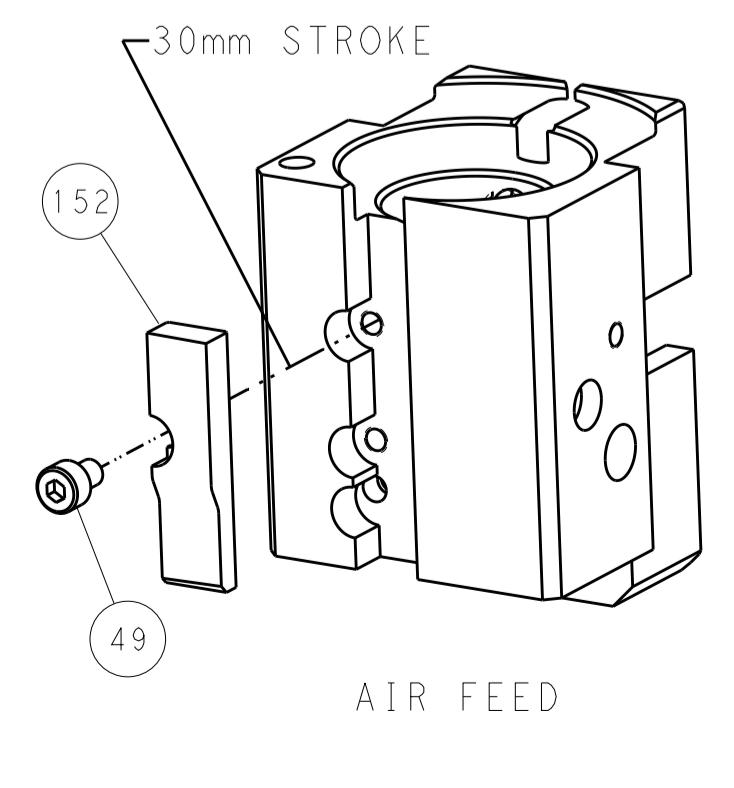

AIR FEED

PACIFIC VERSION
 Shown on sheets 3 of 4 & 4 of 4
 (Atlantic version shown on sheets 1 of 4 & 2 of 4)

DIMENSIONS:		TOLERANCES UNLESS OTHERWISE SPECIFIED:		DWG: Y. YIN 23FEB2012		CHK: G. BAILEY 23FEB2012		NAME: STE TE Connectivity Harrisburg, PA 17105-3608	
mm	0 PLC ±	1 PLC ±	2 PLC ±	3 PLC ±	4 PLC ±	APVD: S. XI 23FEB2012	PRODUCT SPEC	SIZE: A1	CAGE CODE: 00779
	ANGLES ±	FINISH ±	WEIGHT		Customer Accessible Production Drawing		SCALE: 1:1	SHEET: 4	OF: 4
MATERIAL		FINISH		RESTRICTED TO		REV: C		DRAWING NO: C-2150088	