



MAX11503 Evaluation Kit

Evaluates: MAX11503

General Description

The MAX11503 evaluation kit (EV kit) is a fully assembled and tested surface-mount printed-circuit board (PCB). The MAX11503 EV kit evaluates the MAX11503 IC, a video amplifier with Y/C summer and chroma mute. The MAX11503 operates at 3V (typ) and drives two terminated 75Ω loads at an overall gain of +6dB.

Features

- ◆ 2.7V to 5.25V Operating Range
- ◆ DC- or AC-Coupled Input
- ◆ DC- or AC-Coupled Output
- ◆ Surface-Mount Construction
- ◆ Fully Assembled and Tested

Component List

DESIGNATION	QTY	DESCRIPTION
C1	1	10μF ±20%, 6.3V X7R ceramic capacitor (0805) Murata GRM21BR70J106K TDK C2012X7R0J106K or equivalent
C2, C3, C4	3	0.1μF ±10%, 16V X7R ceramic capacitors (0603) Murata GRM188R71C104K TDK C1608X7R1C104KT or equivalent
C5, C6	0	Not installed, aluminum electrolytic capacitors (6.3mm x 6mm)
C_IN, OUT, Y_IN	3	75Ω BNC PCB-mount jack connectors
JU1, JU2	2	3-pin headers
JU3, JU4	2	2-pin headers
R1, R2, R3	3	75Ω ±1% resistors (0603)
R5, R6	2	0Ω resistors (0603)
U1	1	Video filter amplifier (8-pin μMAX®) Maxim MAX11503EUA+
—	4	Shunts
—	1	PCB: MAX11503 Evaluation Kit+

μMAX is a registered trademark of Maxim Integrated Products, Inc.

Ordering Information

PART	TYPE
MAX11503EVKIT+	EV Kit

+Denotes lead-free and RoHS-compliant.

Component Suppliers

SUPPLIER	PHONE	WEBSITE
Murata Mfg. Co., Ltd.	770-436-1300	www.murata.com
TDK Corp.	847-803-6100	www.component.tdk.com

Note: Indicate that you are using the MAX11503 when contacting these component suppliers.



MAX11503 Evaluation Kit

Quick Start

Recommended Equipment

Before beginning, the following equipment is needed:

- 3V DC power supply
- Video signal generator (e.g., Tektronix TG2000 or similar)
- Video measurement equipment (e.g., Tektronix VM700A or similar)

Procedure

The MAX11503 EV kit is a fully assembled and tested surface-mount PCB. Follow the steps below to verify board operation. **Caution: Do not turn on the power supply until all connections are completed.**

- 1) Verify that a shunt is installed across pins 1-2 of jumper JU1 (power-up).
- 2) Verify that a shunt is installed across pins 2-3 of jumper JU2 (summer is enabled).
- 3) Connect the output of the video signal generator to the Y_IN (luma) and C_IN (chroma) BNC connectors on the EV kit.
- 4) Connect the composite CVBS video output signal from the OUT BNC connector on the EV kit to the input of the video measurement equipment.
- 5) Connect a 3V supply to the VCC pad. Connect the supply ground to the GND pad.
- 6) Set the video signal generator for the desired video input signals. This signal must contain sync information (i.e., composite or Y).
- 7) Turn on the power supply and enable the video signal generator.
- 8) Analyze the output signal with the VM700A video measurement equipment.

Detailed Description

The MAX11503 EV kit evaluates the MAX11503 3V operation video amplifier with Y/C summer and a chroma mute that can drive two terminated 75 Ω video loads. The MAX11503 EV kit accepts AC-coupled Y (luma) and C (chroma) input signals summing them into a composite CVBS output signal with gain of +6dB.

Jumper Selection

The EV kit incorporates jumper JU1 to control the $\overline{\text{PSAVE}}$ pin. The $\overline{\text{PSAVE}}$ pin puts the device into a low-power mode. See Table 1 for jumper JU1 settings.

Table 1. Jumper JU1 Settings

SHUNT POSITION	$\overline{\text{PSAVE}}$ PIN	MAX11503 OUTPUT
1-2*	Connected to VCC	Enabled
2-3	Connected to GND	Disabled

*Default position.

The EV kit incorporates jumper JU2 to control the CMUTE pin. The CMUTE pin provides options to enable or disable the chroma input signal from the summer. See Table 2 for jumper JU2 settings.

Table 2. Jumper JU2 Settings

SHUNT POSITION	CMUTE PIN	MAX11503 OUTPUT
1-2	Connected to VCC	Y (luma) signal
2-3*	Connected to GND	Composite CVBS signal

*Default position.

Input Signals

The MAX11503 accepts either DC- or AC-coupled luma input signals that are selected with jumpers JU3 and JU4, as shown in Table 3. The MAX11503 is configured for AC-coupled inputs by default. When using DC-coupled inputs, make sure that the luma input signal has a sync tip near ground.

Table 3. Jumper JU3, JU4 Settings

SHUNT POSITION	MAX11503 INPUT
Installed	DC-coupled
Not installed*	AC-coupled

*Default position.

Output Signal

The MAX11503 EV kit can provide a sag-corrected DC- or AC-coupled composite CVBS or Y (luma) signal. The default output signal is set as DC-coupled composite CVBS. To change the output signal to sag-corrected AC-coupled, remove the R5 and R6 0 Ω resistors and install a 68 μF and a 22 μF aluminum electrolytic capacitor on the C5 and C6 pads, respectively.

MAX11503 Evaluation Kit

Evaluates: MAX11503

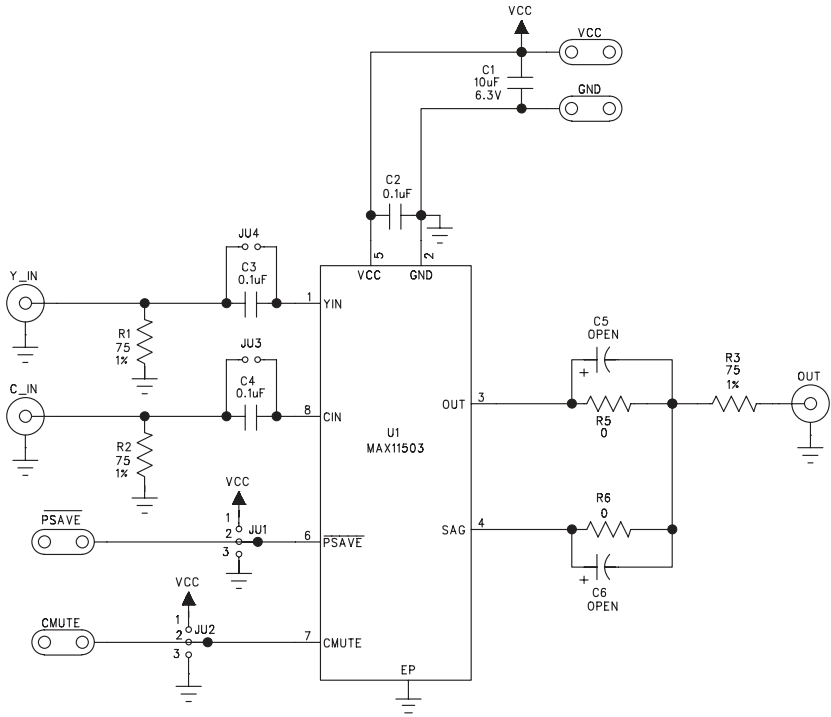

Figure 1. MAX11503 EV Kit Schematic

MAX11503 Evaluation Kit

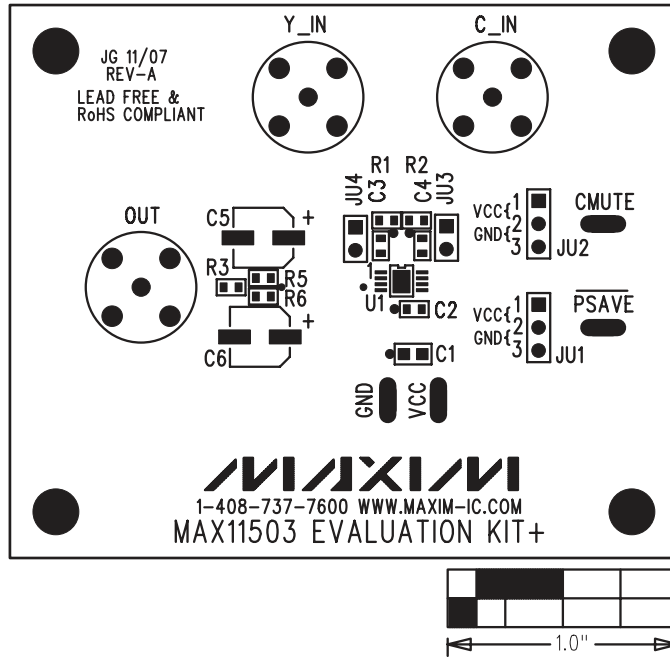

Figure 2. MAX11503 EV Kit Component Placement Guide—Top Silkscreen

MAX11503 Evaluation Kit

Evaluates: MAX11503

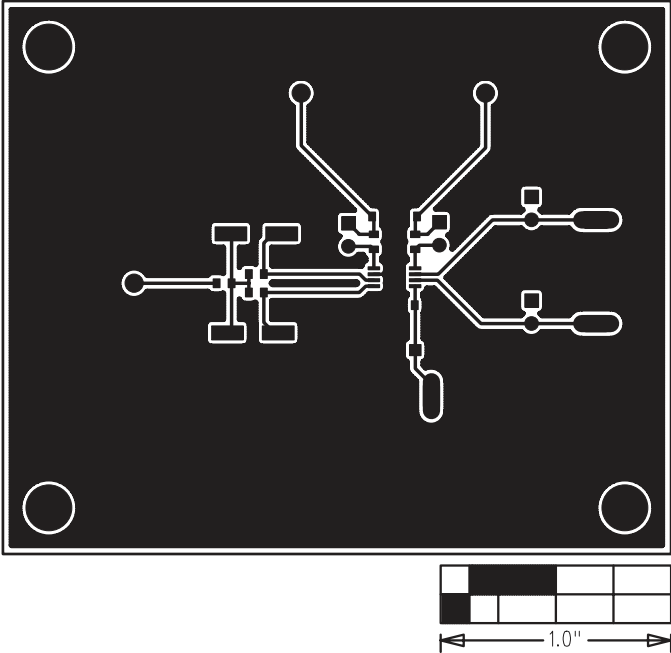

Figure 3. MAX11503 EV Kit PCB Layout—Component Side

MAX11503 Evaluation Kit

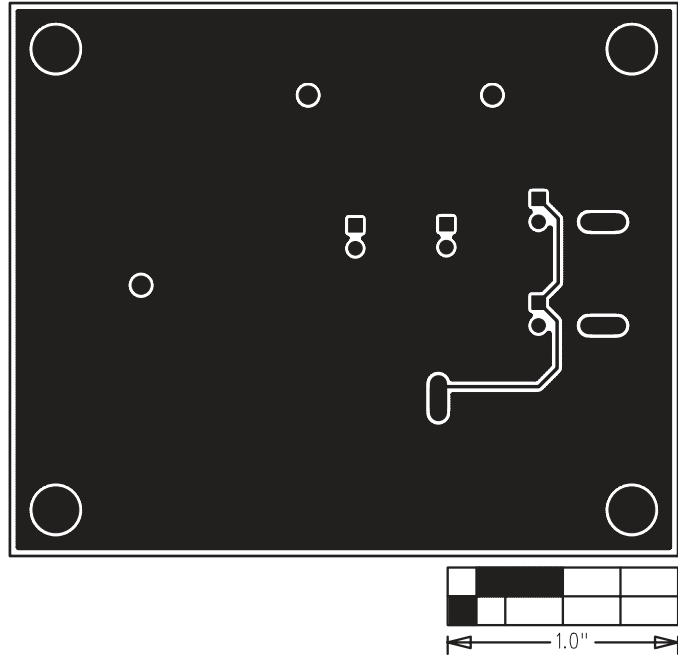

Figure 4. MAX11503 EV Kit PCB Layout—Solder Side

Maxim cannot assume responsibility for use of any circuitry other than circuitry entirely embodied in a Maxim product. No circuit patent licenses are implied. Maxim reserves the right to change the circuitry and specifications without notice at any time.

6 **Maxim Integrated Products, 120 San Gabriel Drive, Sunnyvale, CA 94086 408-737-7600**