

1.2 A current limited high-side power switch with thermal shutdown

Datasheet - production data

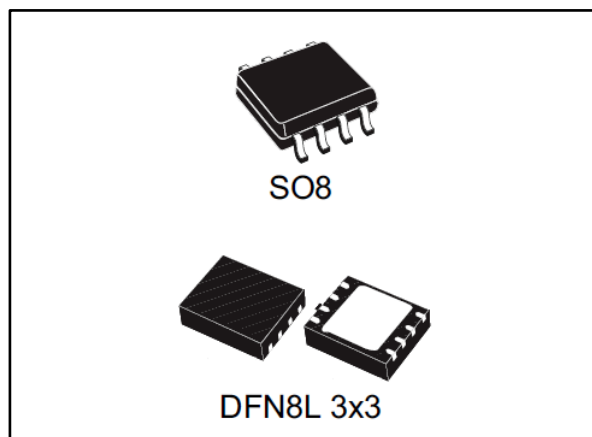

Features

- 2.7 to 5.5 V input range
- Programmable current limit up to 1.2 A
- Low quiescent current
- Thermal shutdown
- Active-low $\overline{\text{FAULT}}$ indicator output
- 90 m Ω (typ.) ON resistance
- SO8 and DFN8L 3x3 packages

Applications

- PCMCIA slots
- Access bus slots
- Portable equipment

Description

The ST890 device is a low voltage, P-channel MOSFET power switch intended for high-side load switching applications.

The switch operates with inputs from 2.7 V to 5.5 V, making it ideal for both 3 V and 5 V systems.

The internal current limiting circuitry protects the input supply against overload. The thermal overload protection limits power dissipation and junction temperatures.

The maximum current limit is 1.2 A. The current limit through the switch is programmed with a resistor from SET to ground. The devices are available in SO8 and DFN8L 3x3 packages.

Contents

1 Device summary 3

2 Pinout information..... 4

3 Absolute maximum ratings and operating conditions 5

4 Electrical information 6

 4.1 Characteristics and timings 6

 4.2 Application circuit 7

 4.3 Functional description 7

 4.3.1 Output current limit 7

 4.3.2 Output short-circuit protection 7

 4.3.3 Programming I_{LIM} 8

 4.3.4 **FAULT** pin..... 8

 4.3.5 Thermal protection..... 8

 4.4 Typical performance characteristics 9

5 Package information 10

 5.1 SO8 package information..... 11

 5.2 SO8 tape and reel information 12

 5.3 DFN8L 3x3 package information..... 13

 5.4 DFN8L 3x3 tape and reel information 15

6 Ordering information..... 17

7 Revision history 18

1 Device summary

Figure 1: Schematic diagram

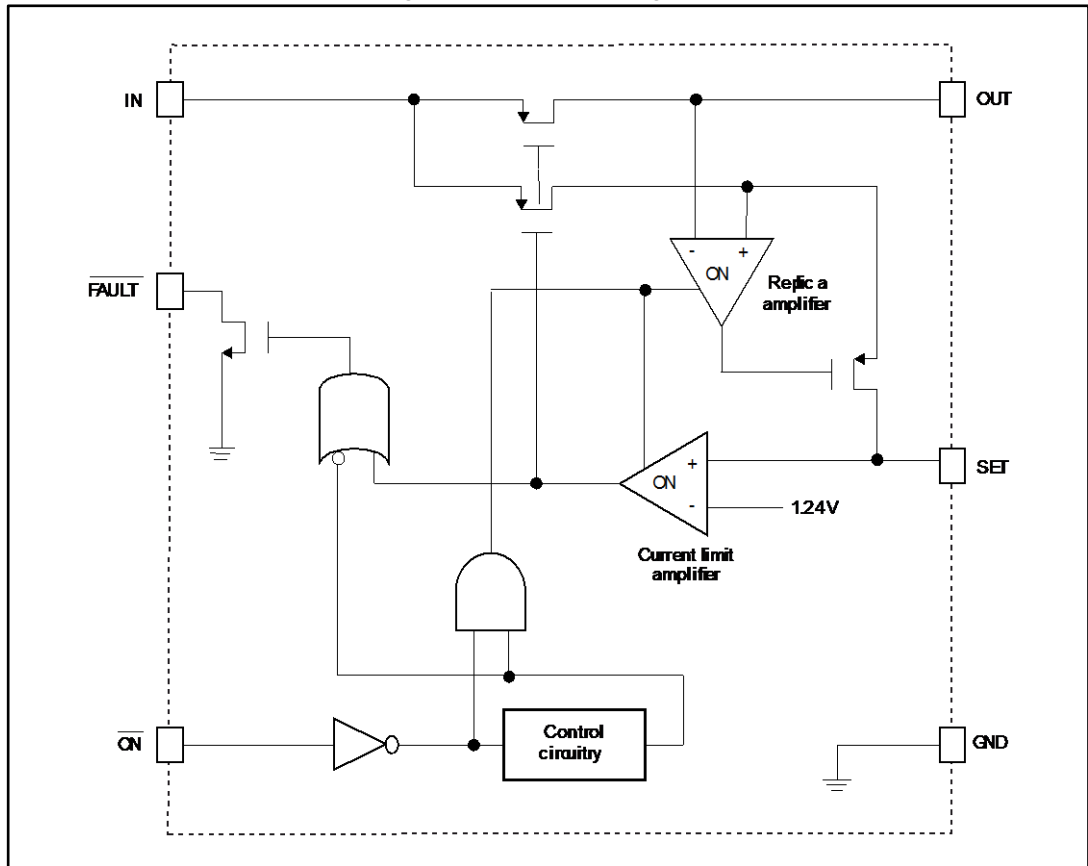

Table 1: Truth table for $\overline{\text{ON}}$ /OFF switch

$\overline{\text{ON}}$ /OFF	OUT
L	ON
H	OFF

Table 2: Truth table for $\overline{\text{FAULT}}$

$\overline{\text{FAULT}}$	FLAG
H	Normal operation
L	Fault condition

2 Pinout information

Figure 2: SO8 and DFN8L 3x3 pin connections (top view)

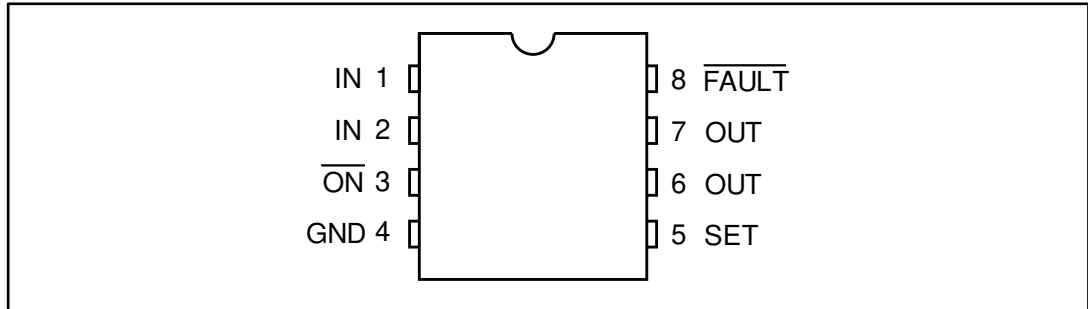

1. The exposed pad of the DFN8L 3x3 is not internally connected. It can be connected to the PCB groundplane for best thermal performance.

Table 3: SO8 and DFN8L 3x3 pin description

Pin no.	Symbol	Name and function
1, 2	IN	Input P-channel MOSFET source. Bypass IN with a 1 μF capacitor to ground.
3	$\overline{\text{ON}}$	Active-low switch ON input. A logic low turns the switch ON.
4	GND	Ground
5	SET	Set current limit input. A resistor from SET to GND sets the current limit for the switch.
6, 7	OUT	Switch output. P-channel MOSFET drain. Bypass OUT with a 0.1 μF capacitor to ground.
8	$\overline{\text{FAULT}}$	Fault indicator output. This open drain output goes low when in current limit or when the die temperature exceeds 135 $^{\circ}\text{C}$.

3 Absolute maximum ratings and operating conditions

Stressing the device above the ratings listed in [Table 4: "Absolute maximum ratings"](#) may cause permanent damage to the device. These are stress ratings only and operation of the device at these or any other conditions above those indicated in of this specification is not implied. Exposure to absolute maximum rating conditions for extended periods may affect device reliability.

Table 4: Absolute maximum ratings

Symbol	Parameter	Value	Unit
V _I	Voltage at IN pin	-0.5 to 6	V
V _{ON}	Input voltage at ON pin	-0.5 to 6	
V _{FAULT_N}	Input voltage at FAULT_N pin	-0.5 to 6	
V _{SET}	Voltage at SET pin	-0.5 to (V _{IN} + 0.5)	
I _{DS}	Maximum continuous switching current	1.5	A
T _{stg}	Storage temperature	-65 to 150	°C

Table 5: Thermal data

Symbol	Parameter	SO8	DFN8L	Unit
R _{thj-amb}	Thermal resistance junction-ambient	160 ⁽¹⁾	37.6 ⁽²⁾	°C/W

Notes:

⁽¹⁾This value depends on the thermal design of the PCB on which the device is mounted.

⁽²⁾This value depends on the four-layer PCB, JEDEC standard test board. For best thermal performance, the exposed pad PCB area should be connected by a via to the PCB groundplane.

Table 6: Operating conditions

Symbol	Parameter	ST890CDR	ST890BDR	ST890DTR	Unit
V _I	Voltage at IN pin	2.7 to 5.5			V
T _{oper}	Operating free-air temperature range	0 to 70	-40 to 85		°C

4 Electrical information

4.1 Characteristics and timings

Table 7: Electrical characteristics

Symbol	Parameter	Test condition ⁽¹⁾	T _A = 25 °C			Unit
			Min.	Typ.	Max.	
V _I	Operating voltage	I _D = 1 mA	2.7		5.5	V
I _{CC}	ON quiescent supply current	V _I = 5 V, $\overline{\text{ON}}$ = GND, I _O = 0		13	25	μA
I _{CCOFF}	OFF quiescent supply current	$\overline{\text{ON}}$ = IN, V _I = V _{OUT} = 5.5 V			1	
		$\overline{\text{ON}}$ = IN, V _I = 5.5 V, V _O = 0			5	
V _{ULO}	Undervoltage lockout	Rising edge	2	2.4	2.6	V
V _{HYST}	Undervoltage lockout hysteresis			100		mV
R _{ON}	ON resistance	V _I = 4.5 V		75	120	mΩ
		V _I = 3 V		90	130	
V _{SET}	Reference voltage to turn the switch OFF	I _O = 100 mA, V _{SET} rise until V _I - V _O > 0.8 V	1.178	1.24	1.302	V
I _{MAX}	Maximum programmable output over current limit			1.2		A
I _{SC}	Short-circuit current limit	V _I = 5 V, OUT connected to GND, device enabled into short-circuit		1.2 I _{LIM}	1.5 I _{LIM}	
I _{LIM} /I _{SET}	I _{LIM} to I _{SET} current ratio	I _O = 500 mA, V _O > 1.6 V	970	1110	1300	
V _{IL}	ON input low level voltage	V _I = 2.7 to 5.5 V			0.8	V
V _{IH}	ON input high level voltage	V _I = 2.7 to 3.6 V	2			
		V _I = 2.7 to 5.5 V	2.4			
I _I	ON input leakage current	V _I = 5.5 V			1	μA
I _{SET bias}	I _{SET} bias current	V _{SET} = 1.24 V, I _O = 0, V _I = V _O		0.5	3	
V _{OL}	$\overline{\text{FAULT}}$ output low voltage	I _{SINK} = 1 mA, V _{SET} = 1.4 V		0.15		V
I _{OH}	$\overline{\text{FAULT}}$ output leakage current	V _{FAULT} = 5.5 V, V _{SET} = 1 V			1	μA
T _{PROT}	Thermal protection			130		°C
T _{HYST}	Thermal hysteresis			15		

Notes:

⁽¹⁾V_{IN} = 3 V, T_A = T_{MIN} to T_{MAX}, unless otherwise specified. Typical values are at T_A = 25 °C

Table 8: Timing characteristics

Symbol	Parameter	Test condition ⁽¹⁾	T _A = 25 °C			Unit
			Min.	Typ.	Max.	
t _{RESP}	Slow current loop response time	20 % current overdrive, V _{CC} = 5 V		5		μs
	Fast current loop response time			2		
t _{ON}	Turn ON time	V _I = 5 V, I _O = 500 mA		25	50	
		V _I = 3 V, I _O = 500 mA		50		
t _{OFF}	Turn OFF time	V _I = 5 V	1	2	10	

Notes:

⁽¹⁾V_{IN} = 3 V, T_A = T_{MIN} to T_{MAX}, unless otherwise specified. Typical values are at T_A = 25 °C

4.2 Application circuit

Figure 3: Typical application circuit

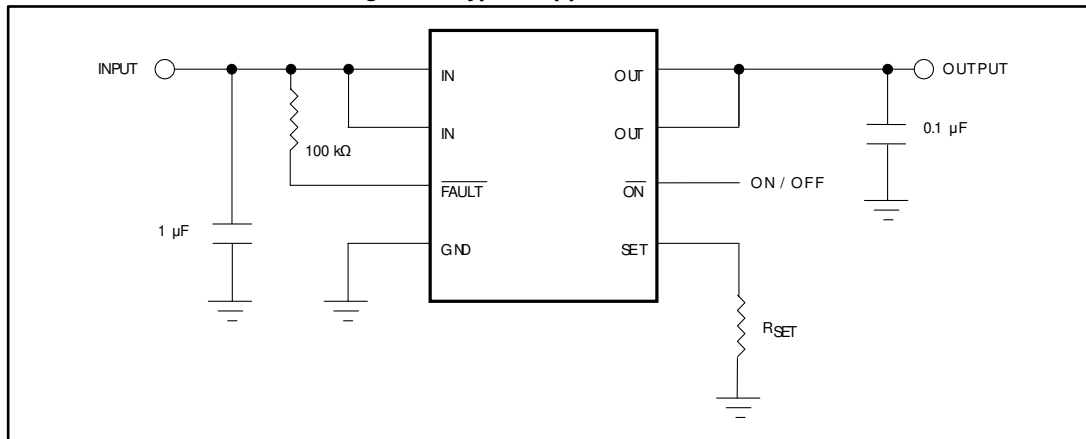

4.3 Functional description

4.3.1 Output current limit

I_{LIM} is the output current that the ST890 device limits under the condition V_O (output voltage) > 1.6 V.

When I_{LIM} is reached, the $\overline{\text{FAULT}}$ pin is asserted.

4.3.2 Output short-circuit protection

The ST890 device provides short-circuit protection by limiting the output current during a short circuit event.

I_{sc} is the output short-circuit current limit level (typ. 1.2 x I_{LIM}). When a short circuit event occurs on the output, such as V_O < 1.6 V, the ST890 device limits the output current to no more than the I_{sc} level.

When a short circuit event occurs on the output, the $\overline{\text{FAULT}}$ pin is asserted.

4.3.3 Programming I_{LIM}

The ST890's I_{LIM} can be programmed through the external resistor, R_{SET} , connected at the SET pin (pin 5).

I_{LIM} is determined by the equations below.

Equation 1

$$I_{SET} = \frac{V_{SET}}{R_{SET}}$$

Equation 2

$$\frac{I_{LIM}}{I_{SET}} = 1110$$

Therefore:

Equation 3

$$R_{SET} = 1.24 \times \frac{1110}{I_{LIM}}$$

4.3.4 $\overline{\text{FAULT}}$ pin

The $\overline{\text{FAULT}}$ pin (pin 8) is an open drain active-low output. This pin should be connected to an external pull-up resistor.

The $\overline{\text{FAULT}}$ pin is asserted low when:

- I_{OUT} reaches the programmed I_{LIM} value
- A short-circuit event occurs
- The device goes into thermal protection

4.3.5 Thermal protection

The thermal protection of the ST890 is triggered to turn off the switch when the junction temperature exceeds 130 °C (typ.).

4.4 Typical performance characteristics

Unless otherwise specified $T_j = 25\text{ }^\circ\text{C}$.

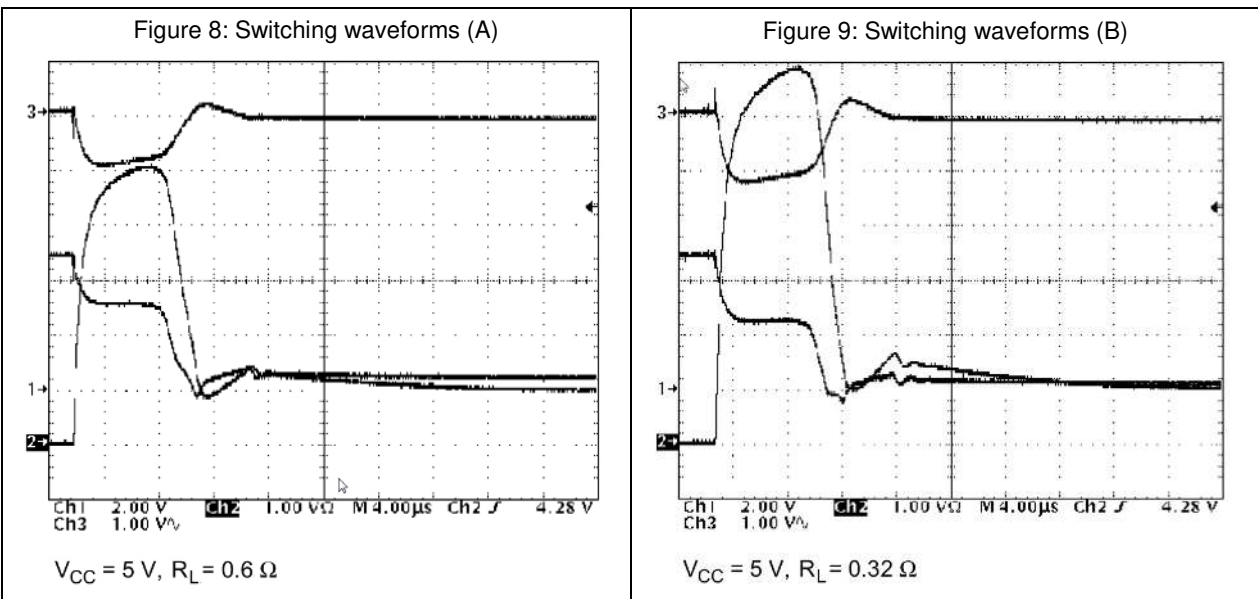
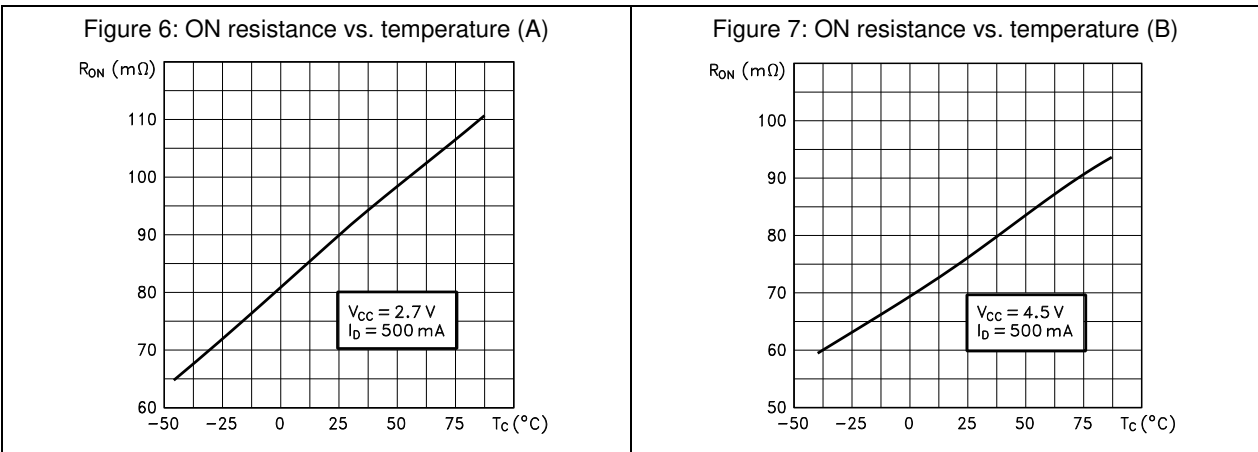
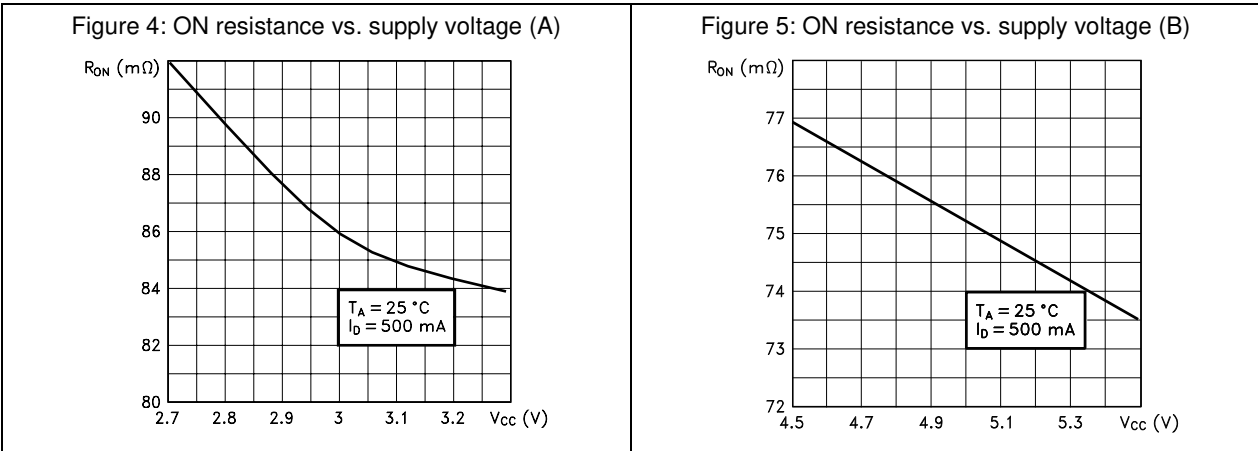

5 Package information

In order to meet environmental requirements, ST offers these devices in different grades of ECOPACK® packages, depending on their level of environmental compliance. ECOPACK® specifications, grade definitions and product status are available at: www.st.com. ECOPACK® is an ST trademark.

5.1 SO8 package information

Figure 10: SO8 package outline

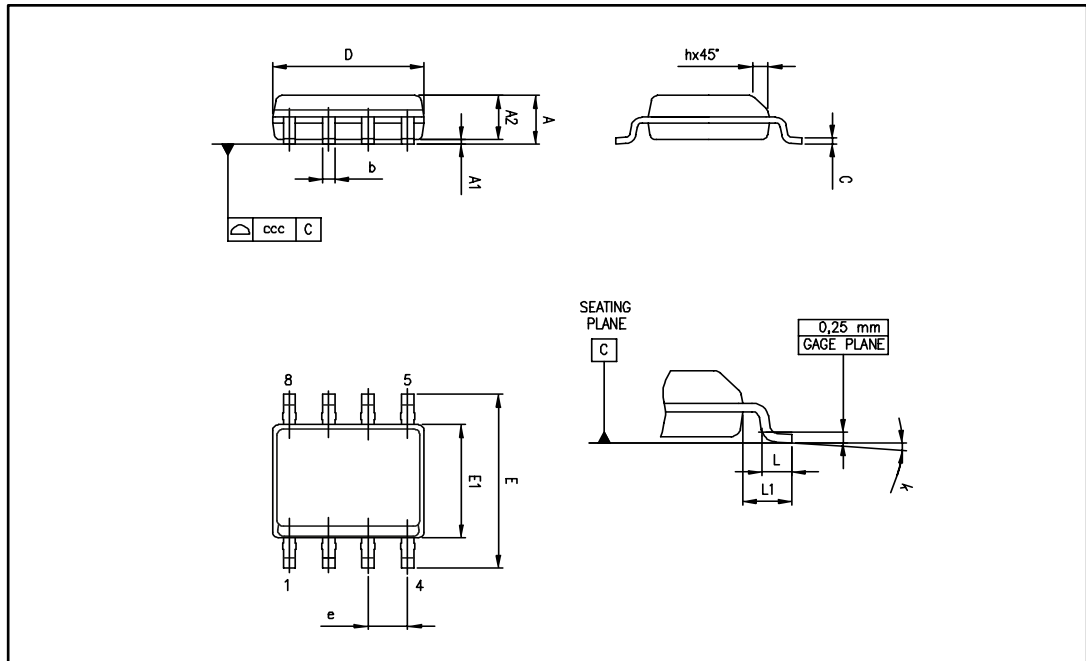
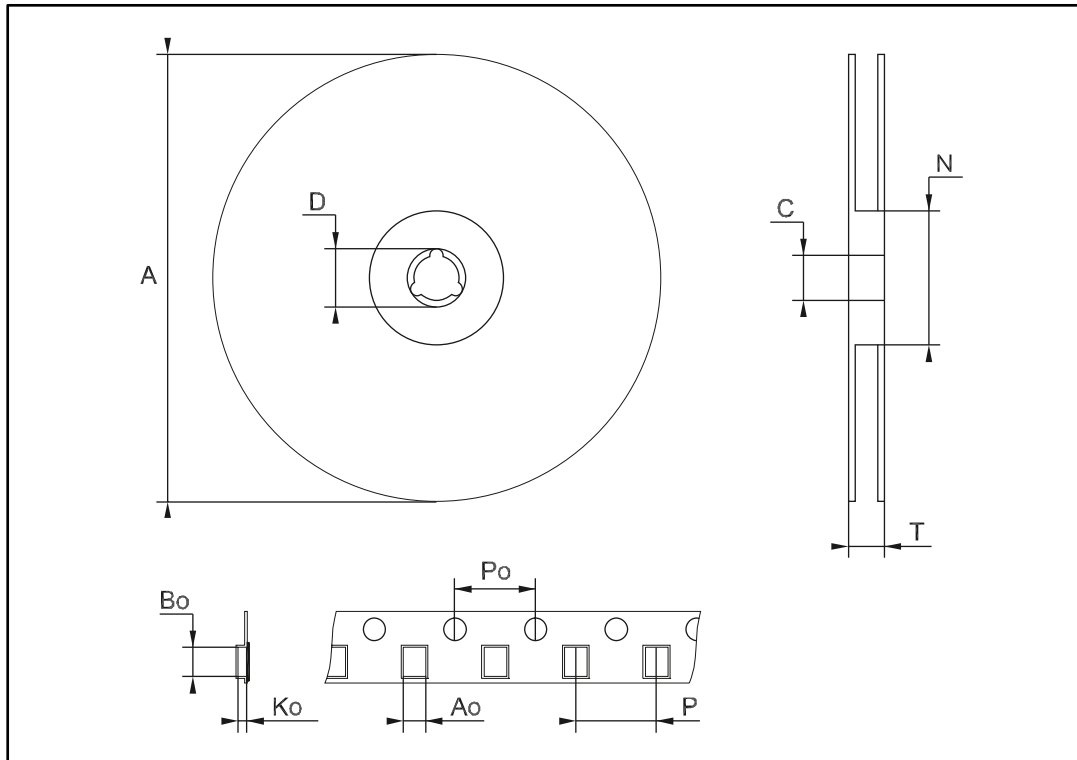

Table 9: SO8 mechanical data

Ref.	Dimensions					
	Millimeters			Inches		
	Min.	Typ.	Max.	Min.	Typ.	Max
A			1.75			0.069
A1	0.10		0.25	0.004		0.010
A2	1.25			0.049		
b	0.28		0.48	0.011		0.019
c	0.17		0.23	0.007		0.010
D	4.80	4.90	5.00	0.189	0.193	0.197
E	5.80	6.00	6.20	0.228	0.236	0.244
E1	3.80	3.90	4.00	0.150	0.154	0.157
e		1.27			0.050	
h	0.25		0.50	0.010		0.020
L	0.40		1.27	0.016		0.050
L1		1.04			0.040	
k	0°		8°	0°		8°
ccc			0.10			0.004

5.2 SO8 tape and reel information

Figure 11: SO8 tape and reel outline



1. Drawing not to scale

Table 10: SO8 tape and reel mechanical data

Symbol	Dimensions					
	mm			Inches		
	Min.	Typ.	Max.	Min.	Typ.	Max.
A			330			12.992
C	12.8		13.2	0.504		0.519
D	20.2			0.795		
N	60			2.362		
T			22.4			0.882
Ao	8.1	—	8.5	0.319	—	0.335
Bo	5.5		5.9	0.216		0.232
Ko	2.1		2.3	0.082		0.090
Po	3.9		4.1	0.153		0.161
P	7.9		8.1	0.311		0.319

5.3 DFN8L 3x3 package information

Figure 12: DFN8L 3x3 package outline

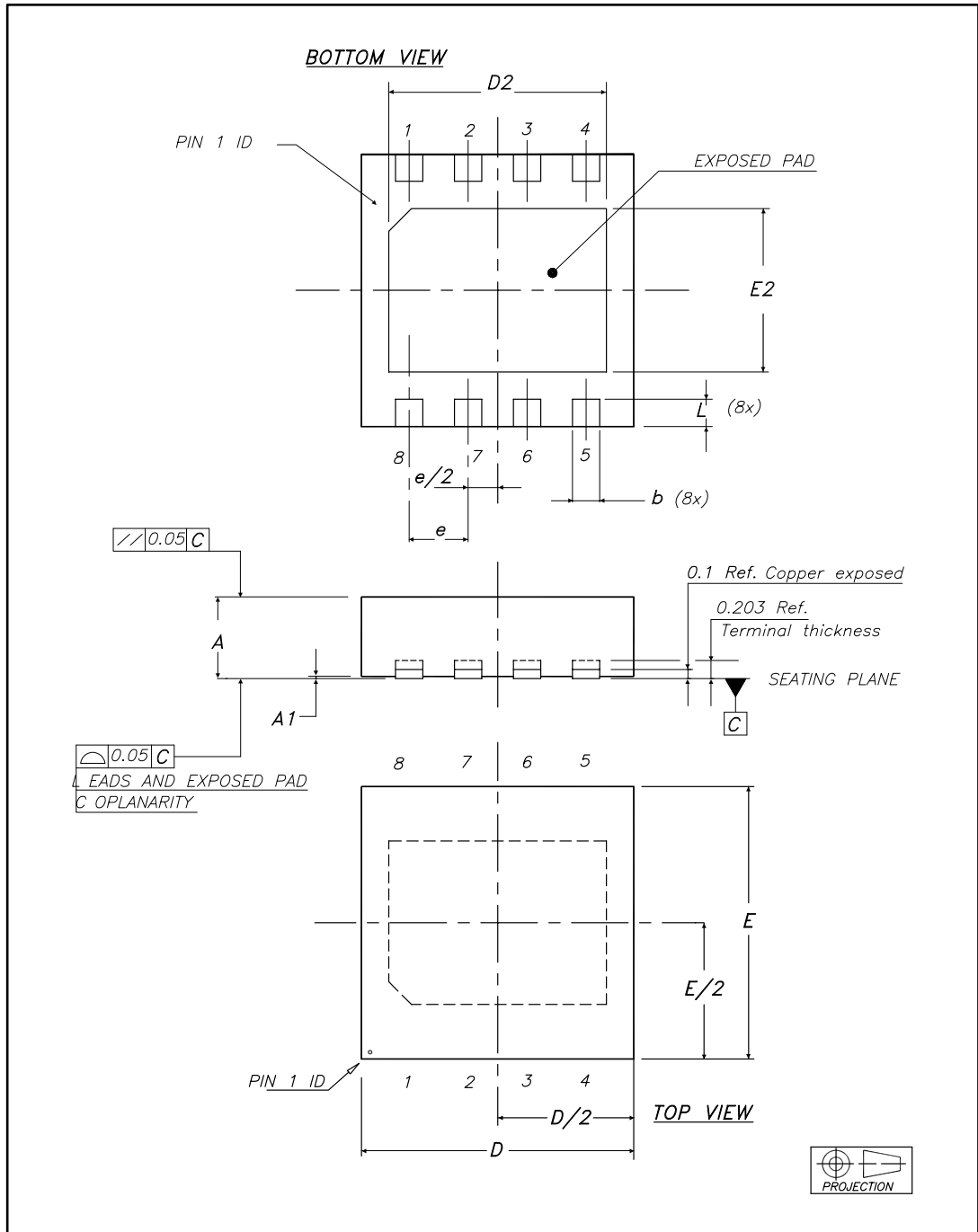

1. Drawing is not to scale
2. Dimensions in millimeters

Table 11: DFN8L 3x3 mechanical data

Ref.	Dimensions					
	Millimeters			Inches		
	Min.	Typ.	Max.	Min.	Typ.	Max
A	0.80	0.85	0.90	0.031	0.033	0.035
A1	0	0.02	0.05	0	0.001	0.002
b	0.25	0.030	0.35	0.010	0.001	0.014
D	2.95	3	3.05	0.116	0.118	0.120
D2	2.30	2.40	2.50	0.091	0.094	0.098
E	2.95	3	3.05	0.116	0.118	0.120
E2	1.70	1.80	1.90	0.067	0.071	0.075
e		0.65			0.026	
L	0.25	0.30	0.35	0.010	0.012	0.014

Figure 13: DFN8L 3x3 recommended footprint

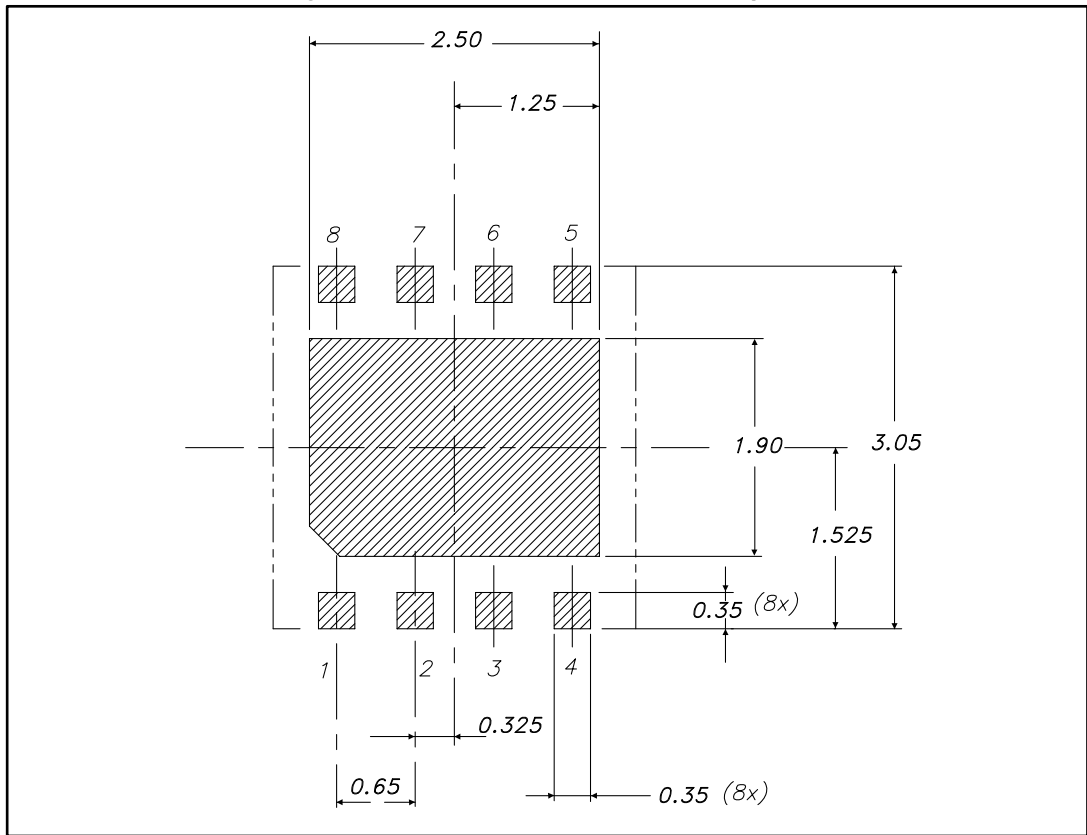

1. Drawing not to scale
2. Dimensions in millimeters

5.4 DFN8L 3x3 tape and reel information

Figure 14: DFN8L 3x3 tape and reel outline

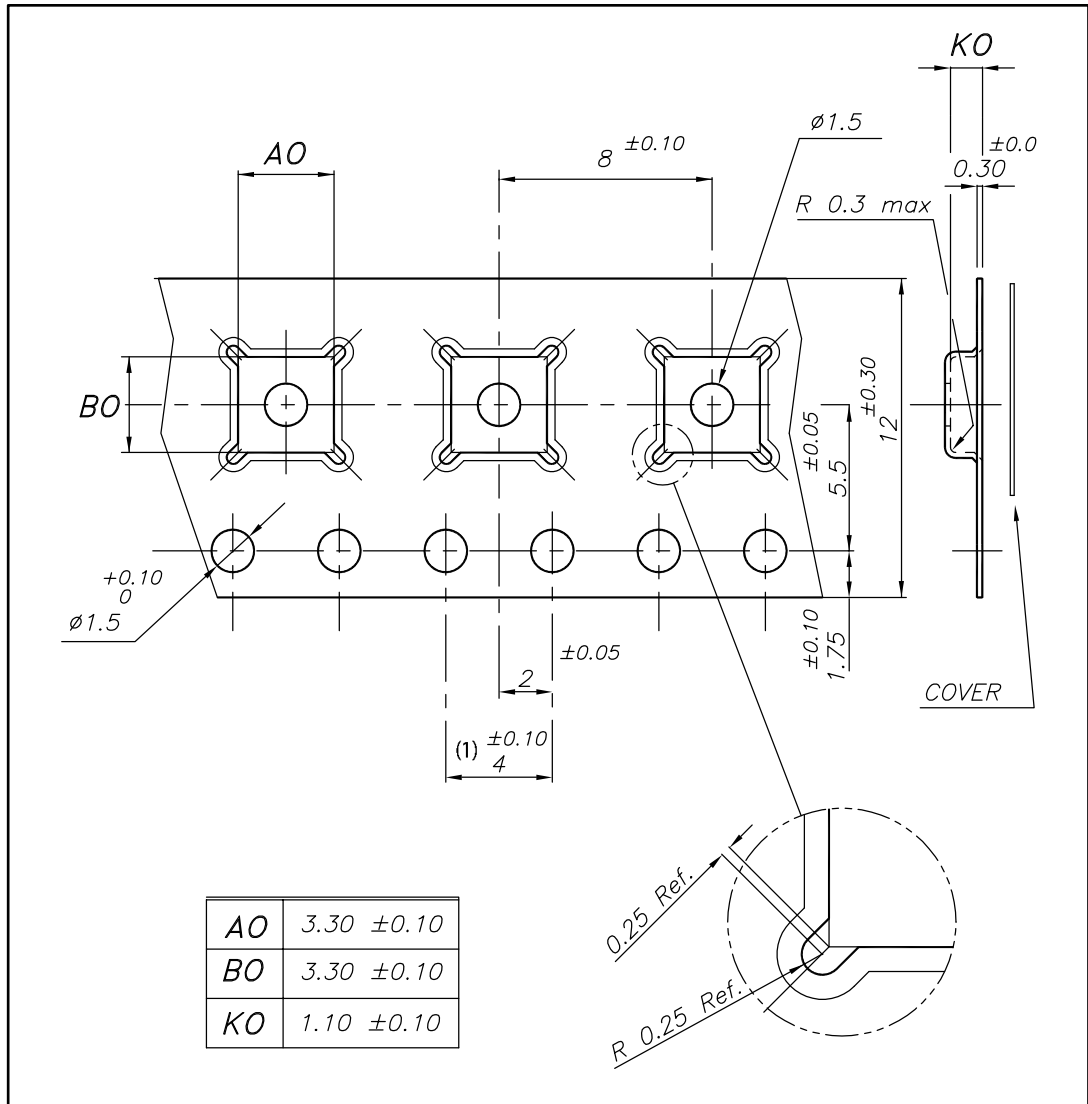

1. 10 sprocket hole pitch cumulative tolerance ±0.20

Figure 15: DFN8L 3x3 reel outline

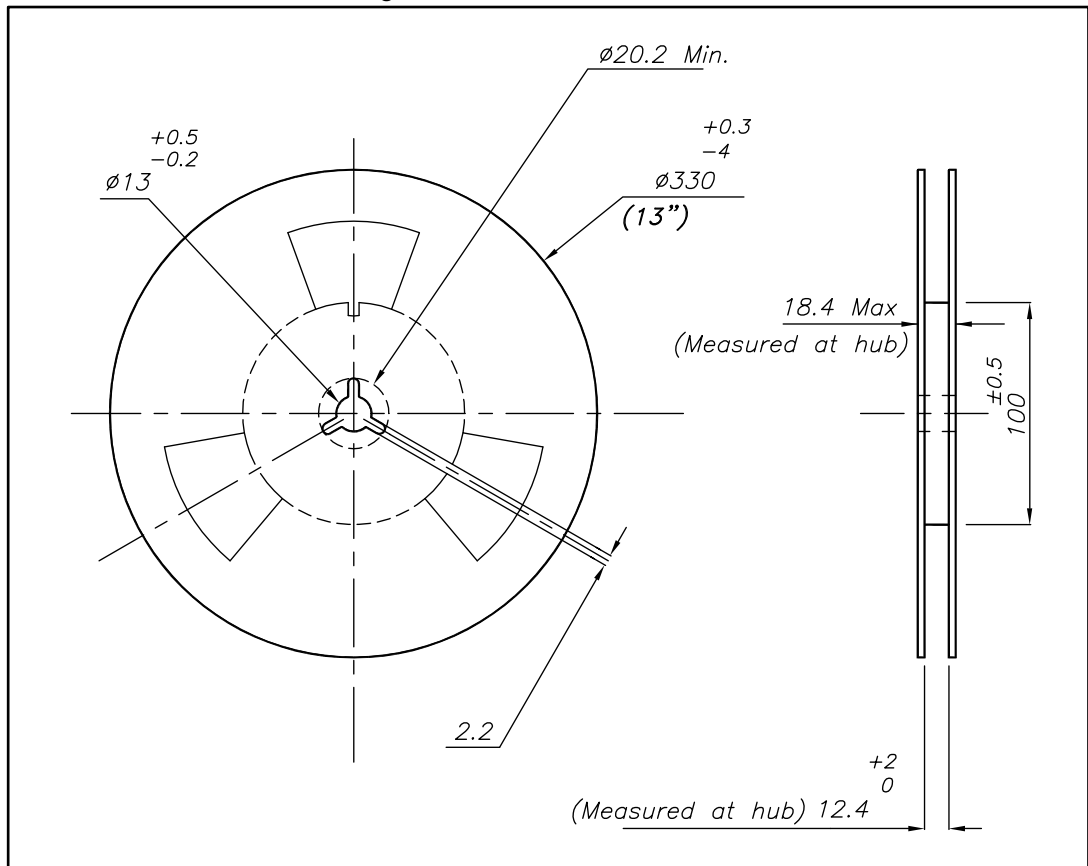

6 Ordering information

Table 12: Order codes

Order code	Temperature range	Package	Packaging	Marking
ST890CDR	0 to 70 °C	SO8	Tape and reel	ST890C
ST890BDR	-40 to 85 °C			DFN8L 3x3
ST890DTR				UD91

7 Revision history

Table 13: Document revision history

Date	Revision	Changes
22-Jul-2005	4	Added 3 rows on Table 2 on page 3
10-Aug-2007	5	Removed ST890CD and ST890BD from Table 1 on page 1 Updated short circuit current limit value in Table 8 on page 7
1-Dec-2007	6	Added Section : Contents. Added ST890D and related DFN8L package information. Added Figure 2: DFN8L (3 x 3 mm) pin connection (top view) on page 4. Figure 3: Schematic diagram on page 5: redrawn, no content change. Modified title in Table 5: Truth table for FAULT on page 5. Updated Table 8: Electrical characteristics on page 7. Figure 4: Typical application circuit on page 8: redrawn, no content change.
13-Oct-2008	7	Updated: Table 2 on page 3, Table 3 on page 4. Added: Section 2.1: Functional description on page 9 and Figure 12 on page 18.
04-Mar-2009	8	Replaced ST890B, ST890C and ST890D with ST890. Modified: Table 6: Absolute maximum ratings
25-Jan-2013	9	Updated Figure 1, Figure 3, Table 5, Section 2.1 (overlined " $\overline{\text{FAULT}}$ " and " $\overline{\text{ON}}$ " pin, minor corrections). Updated Table 3 (added "Exposed pad"). Added cross-references to Section 2. Updated note 2. below Table 7. Updated Table 8 (parameter of I_{OH} symbol corrected to " $\overline{\text{FAULT}}$ output leakage current"). Updated ECOPACK in Section 3. Minor corrections throughout document.
12-Dec-2016	10	Updated datasheet layout <i>Table 4: "Absolute maximum ratings"</i> : removed reference to the "SURE" program, updated name of parameter V_I , and removed parameter T_{op} . Added <i>Table 6: "Operating conditions"</i> Updated SO8 package information <i>Table 11: "DFN8L 3x3 mechanical data"</i> : added inches dimensions Added <i>Table 12: "Order codes"</i>

IMPORTANT NOTICE – PLEASE READ CAREFULLY

STMicroelectronics NV and its subsidiaries ("ST") reserve the right to make changes, corrections, enhancements, modifications, and improvements to ST products and/or to this document at any time without notice. Purchasers should obtain the latest relevant information on ST products before placing orders. ST products are sold pursuant to ST's terms and conditions of sale in place at the time of order acknowledgement.

Purchasers are solely responsible for the choice, selection, and use of ST products and ST assumes no liability for application assistance or the design of Purchasers' products.

No license, express or implied, to any intellectual property right is granted by ST herein.

Resale of ST products with provisions different from the information set forth herein shall void any warranty granted by ST for such product.

ST and the ST logo are trademarks of ST. All other product or service names are the property of their respective owners.

Information in this document supersedes and replaces information previously supplied in any prior versions of this document.

© 2016 STMicroelectronics – All rights reserved