



# Atmel LED Drivers

## MSL2041/MSL2042

Low-cost, Simple 4-string LED Drivers with External Current Sink MOSFETs, 5000:1 Dimming Range and Per String PWM Input

Datasheet Brief



# Atmel LED Drivers-MSL2041/MSL2042

Low-cost, Simple 4-string LED Drivers with External Current Sink MOSFETs, 5000:1 Dimming Range and Per String PWM Input

## General Description

The Atmel® LED Drivers-MSL2041 and MSL2042 compact, high-power LED string controllers use external current control MOSFETs to sink up to 1A per string, with string current matching of  $\pm 0.5\%$ . The MSL2041/2 drive four parallel strings of LEDs and offer fault detection and management of open circuit and short circuit LEDs. The MSL2041 features four PWM inputs that allow independent frequency, dimming and phasing of each string, while the MSL2042 offers one PWM input for frequency and dimming control of all four strings, and automatically phase shifts the string drive signals. Peak string currents are set using current sense (FET source) resistors and adjustable with an internal 8-bit DAC.

The MSL2041/2 adaptively control up to two DC-DC converters that power the LED strings, using Atmel's Adaptive SourcePower™ technology. These Efficiency Optimizers minimize power use while maintaining LED current accuracy. Multiple MSL2041/2s cascade to automatically negotiate the optimum power supply voltage when driving more than four strings from a single power supply.

The MSL2041/2 features fault control for open-circuit strings, LED short-circuits and device over-temperature conditions. When a string open-circuit or LED short-circuit condition is detected, the MSL2041/2 turn off the faulty string and pull the open-drain fault output low.

The MSL2041/2 feature stand-alone operation, and the basic circuit requires just one to four external PWM dimming inputs. An I<sup>2</sup>C serial interface is provided to allow optional control and monitoring of the various fault detection and Adaptive SourcePower parameters, but is not required for operation.

The MSL2041/2 are offered in the 32-pin, 300mil SOP package, and operate over the -40°C to +85°C temperature range.

## Applications

- LCD-TVs
- PC Monitors
- Industrial Displays
- General Illumination
- Street-lighting
- Post-regulated or Offline Powered LED Strings

## Ordering Information

PART NO.	PWM INPUTS	AUTO-PHASE DELAY	PACKAGE
MSL2041GU	4	NO	32 pin, 300mil SOP
MSL2042GU	1	YES	32 pin, 300mil SOP

# Atmel LED Drivers-MSL2041/MSL2042

Low-cost, Simple 4-string LED Drivers with External Current Sink MOSFETs, 5000:1 Dimming Range and Per String PWM Input

## Key Features

- Drives Four Parallel High Power LED Strings
- Up to 1A LED String Current with External N-channel MOSFETs
- Operates Stand-alone, Basic Circuit Needs Only PWM Input(s)
- Four PWM Inputs Allow Individual Frequency, Brightness and Phase Control of each LED String (MSL2041)
- One PWM Input Controls the Frequency and Brightness of the Automatically Phase Shifted Strings (MSL2042)
- 8-bit Adaptive SourcePower™ Correction Optimizes String Power Supply for Maximum Efficiency
- Multiple MSL2041/2s Share a String Supply and Automatically Negotiate the Optimum Supply Voltage
- $\pm 0.5\%$  Current Matching Between Strings
- String Open-circuit and LED Short-circuit Fault Detection and Protection
- External MOSFETs Offer Flexibility of LEDs Used in Each String
- I<sup>2</sup>C Serial Interface Allows Optional Control of Device Functions and Faults
- 32-pin 300mil SOP Package
- -40°C To +85°C Operating Temperature Range
- Lead-Free, Halogen-free, RoHS Compliant Package

## Application Circuit

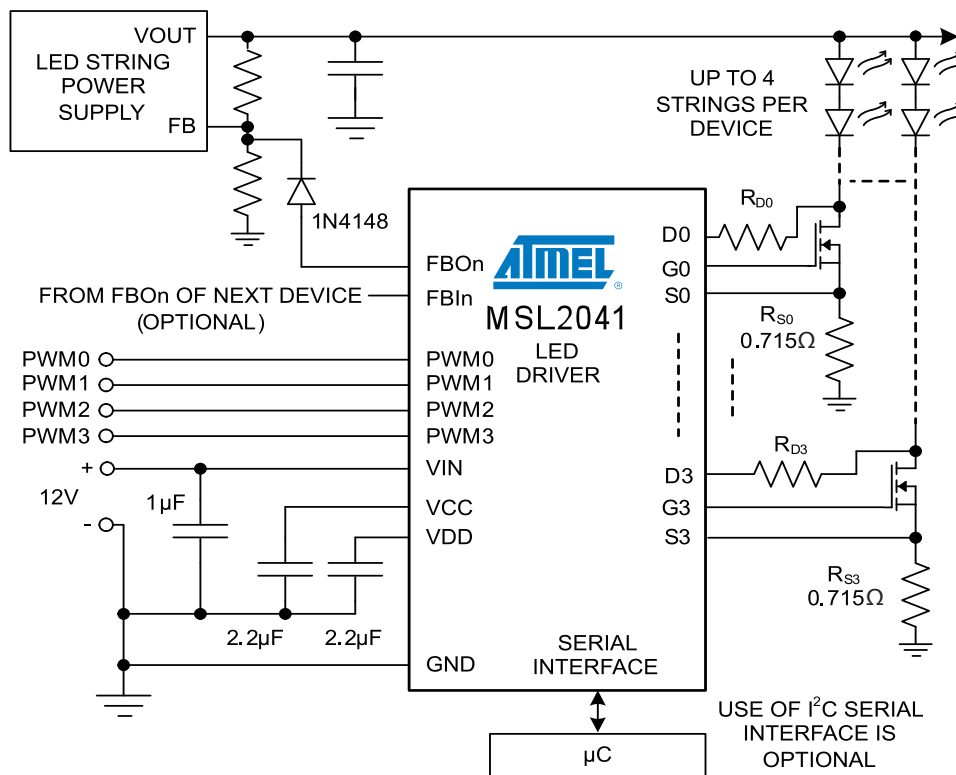



## Package and Pinout – SOP

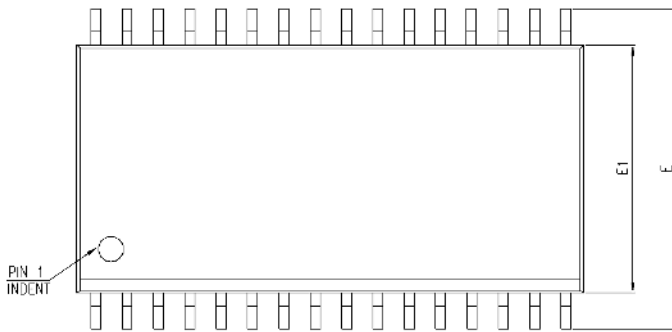
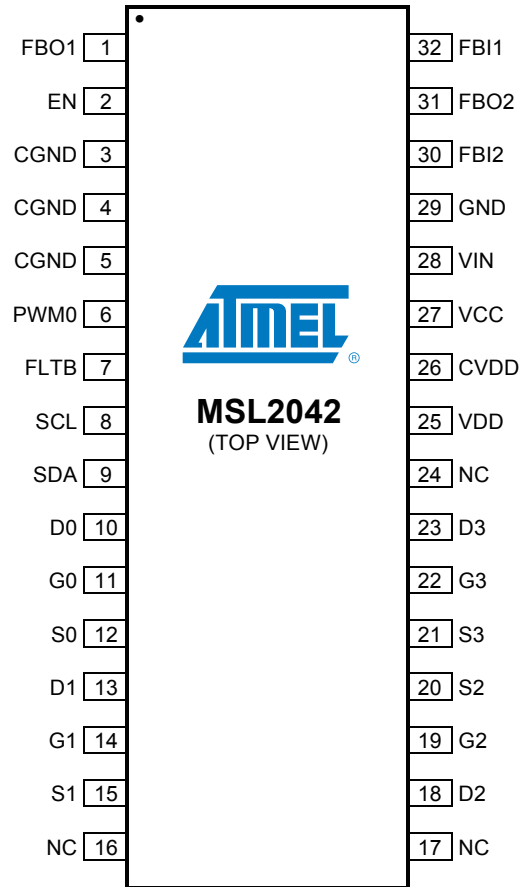
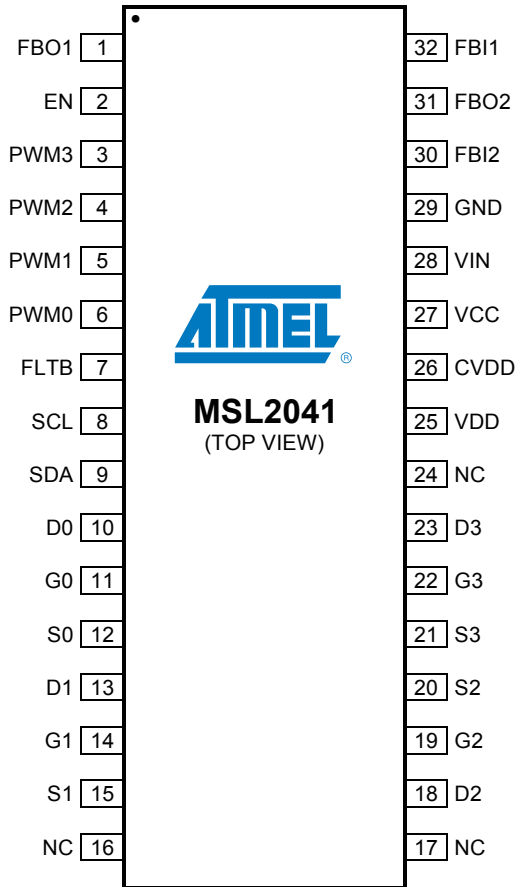

SYMBOLS	DIMENSIONS IN MILLIMETERS			DIMENSIONS IN INCHES		
	MIN	NOM	MAX	MIN	NOM	MAX
A	2.36	2.49	2.64	0.093	0.098	0.104
A1	0.10	—	0.30	0.004	—	0.012
A2	—	2.34	—	—	0.092	—
b	0.33	0.41	0.51	0.013	0.016	0.020
c	0.23	0.25	0.30	0.009	0.010	0.012
D	20.32	20.52	20.73	0.800	0.808	0.816
E1	7.39	7.49	7.59	0.291	0.295	0.299
E	10.01	10.31	10.64	0.394	0.406	0.419
e	—	1.27	—	—	0.050	—
L	0.38	0.81	1.27	0.015	0.032	0.050
y	—	—	0.076	—	—	0.003
φ	0"	—	8"	0"	—	8"

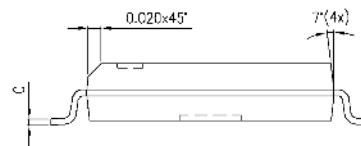
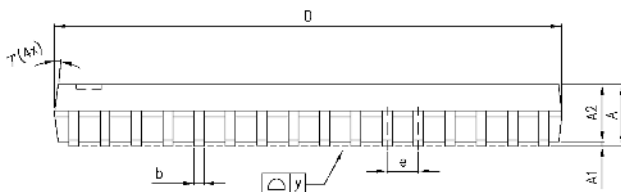

Package Dimensions: 32 Pin 20.52mm x 7.49mm x 2.49mm SOP (1.27mm pin pitch)

# Atmel LED Drivers-MSL2041/MSL2042

Low-cost, Simple 4-string LED Drivers with External Current Sink MOSFETs, 5000:1 Dimming Range and Per String PWM Input

## Pin Descriptions

PIN		NAME	DESCRIPTION
MSL2041	MSL2042		
1	1	FBO1	<b>Efficiency optimizer feedback output 1</b> Connect FBO1 to the feedback node of the first external string power supply through a diode, or to FBO1 of the next device when operating the devices in a chain configuration. If unused, leave FBO1 unconnected.
2	2	EN	<b>Enable input (Active high)</b> Drive EN high to turn on the MSL2041/2, drive it low to turn off the MSL2041/2. For automatic startup connect EN to VIN through a 100kΩ resistor. Toggle EN low to release FLTB and to return any and all registers to their power-up default values.
3	-	PWM3	<b>PWM dimming input 3</b> Drive PWM3 with a pulse-width modulated signal to control the brightness of string three. If unused, connect PWM3 to ground.
4	-	PWM2	<b>PWM dimming input 2</b> Drive PWM2 with a pulse-width modulated signal to control the brightness of string two. If unused, connect PWM2 to ground.
5	-	PWM1	<b>PWM dimming input 1</b> Drive PWM1 with a pulse-width modulated signal to control the brightness of string one. If unused, connect PWM1 to ground.
6	6	PWM0	<b>Pwm dimming input 0</b> Drive PWM0 with a pulse-width modulated signal to control the brightness of string zero (MSL2041) or all strings (MSL2042).
7	7	FLTB	<b>Fault indication output (Open drain, active low)</b> FLTB sinks current to GND whenever the MSL2041/2 detects and verifies a fault condition. Toggle EN low (or read the fault registers) to clear FLTB.
8	8	SCL	<b>I<sup>2</sup>C serial clock input</b> SCL is the I <sup>2</sup> C serial interface clock input.
9	9	SDA	<b>I<sup>2</sup>C serial data I/O</b> SDA is the I <sup>2</sup> C serial interface bi-directional data line.
10	10	D0	<b>Drain sense input 0</b> Drain Sense Input for External MOSFET 0. Connect D0 through a resistor to the drain of the external MOSFET driving LED string 0. If unused, connect D0 to ground.
11	11	G0	<b>Gate output 0</b> Gate drive output for external MOSFET 0. Connect G0 to the gate of the external MOSFET driving LED string 0. If unused, connect G0 to ground.
12	12	S0	<b>Source sense input for string 0</b> Connect S0 to the source of the external MOSFET, and to the current sense resistor for LED string 0. The full scale LED current is reached when 500mV is across the current sense resistor. If unused, connect S0 to VDD.
13	13	D1	<b>Drain sense input 1</b> Drain Sense Input for External MOSFET 1. Connect D1 through a resistor to the drain of the external MOSFET driving LED string 1. If unused, connect D1 to ground.
14	14	G1	<b>Gate output 1</b> Gate drive output for external MOSFET 1. Connect G1 to the gate of the external MOSFET driving LED string 1. If unused, connect G1 to ground.
15	15	S1	<b>Source sense input for string 1</b> Connect S1 to the source of the external MOSFET, and to the current sense resistor for LED string 1. The full scale LED current is reached when 500mV is across the current sense resistor. If unused, connect S1 to VDD.
16, 17, 24	16, 17, 24	NC	<b>No internal connection</b> NC is not internally connected .
18	18	D2	<b>Drain sense input 2</b> Drain Sense Input for External MOSFET 2. Connect D2 through a resistor to the drain of the external MOSFET driving LED string 2. If unused, connect D2 to ground.



PIN		NAME	DESCRIPTION
MSL2041	MSL2042		
19	19	G2	<b>Gate output 2</b> Gate drive output for external MOSFET 2. Connect G2 to the gate of the external MOSFET driving LED string 2. If unused, connect G2 to ground.
20	20	S2	<b>Source sense input for string 2</b> Connect S2 to the source of the external MOSFET, and to the current sense resistor for LED string 2. The full scale LED current is reached when 500mV is across the current sense resistor. If unused, connect S2 to VDD.
21	21	S3	<b>Source sense input for string 3</b> Connect S3 to the source of the external MOSFET, and to the current sense resistor for LED string 3. The full scale LED current is reached when 500mV is across the current sense resistor. If unused, connect S3 to VDD.
22	22	G3	<b>Gate output 3</b> Gate drive output for external MOSFET 3. Connect G3 to the gate of the external MOSFET driving LED string 3. If unused, connect G3 to ground.
23	23	D3	<b>Drain sense input 3</b> Drain Sense Input for External MOSFET 3. Connect D3 through a resistor to the drain of the external MOSFET driving LED string 3. If unused, connect D3 to ground.
25	25	VDD	<b>2.5V internal LDO regulator output</b> VDD powers internal logic. Bypass VDD to GND with a 2.2µF ceramic capacitor placed close to VDD.
26	26	CVDD	<b>Connect to VDD</b> Connect CVDD to VDD.
27	27	VCC	<b>5V internal LDO regulator output</b> VCC powers internal logic. Bypass VCC to GND with a 2.2µF ceramic capacitor placed close to VCC.
28	28	VIN	<b>Supply voltage input</b> Connect a 12V ±10% supply to VIN. Bypass VIN to GND with a 1.0µF ceramic capacitor.
29	29	GND	<b>Power ground</b> Connect GND to system ground.
30	30	FBI2	<b>Efficiency Optimizer feedback input 2</b> Connect FBI2 to FBO2 of the previous device when using the devices in a chain configuration. If unused, connect FBI2 to ground.
31	31	FBO2	<b>Efficiency Optimizer feedback output 2</b> Connect FBO2 to the feedback node of the second external string power supply through a diode, or to FBI2 of the next device when operating the devices in a chain configuration. If unused, leave FBO2 unconnected.
32	32	FBI1	<b>Efficiency Optimizer feedback input 1</b> Connect FBI1 to FBO1 of the previous device when using the devices in a chain configuration. If unused, connect FBI1 to ground.
-	3, 4, 5	CGND	<b>Connect to ground</b> Connect all CGND pins to GND as close to the MSL2042 as possible.

# Atmel LED Drivers-MSL2041/MSL2042

Low-cost, Simple 4-string LED Drivers with External Current Sink MOSFETs, 5000:1 Dimming Range and Per String PWM Input

## Absolute Maximum Ratings

### Voltage – With Respect to GND (SOP), EP/GND (TQFN)

VIN, EN, G0 - G3.....	-0.3V to +16V
D0 - D3.....	-0.3V to +24V
VDD, CVDD.....	-0.3V to +2.75V
VCC.....	-0.3V to +5.5V
SDA, SCL, PWM0 - PWM3.....	-0.3V to +5.5V
FBI1, FBI2, FBO1, FBO2, FLTB.....	-0.3V to (VCC + 0.3V)

### Current – (Into Pin)

VIN.....	50mA
GND.....	500mA
D0 - D3.....	1mA
All other pins.....	20mA

### Continuous Power Dissipation at 70°C

32-Pin SOP (derate 28.7mW/°C above $T_A = +70^\circ\text{C}$ ).....	1576mW
---	--------

**Ambient Operating Temperature Range  $T_A = T_{MIN}$  to  $T_{MAX}$** ..... -40°C to +85°C

**Junction Temperature** ..... +125°C

**Storage Temperature Range**..... -65°C to +125°C

**Lead Soldering Temperature, 10s**.....+300°C



## Electrical Characteristics

V<sub>IN</sub> = 12V, T<sub>A</sub> = T<sub>MIN</sub> to T<sub>MAX</sub>, unless otherwise noted. Typical values are at V<sub>IN</sub> = 12V, T<sub>A</sub> = +25°C.

PARAMETER	SYMBOL	CONDITIONS	MIN	TYP	MAX	UNIT
<b>DC ELECTRICAL CHARACTERISTICS</b>						
VIN Operating Supply Voltage			10.8	12.0	13.2	V
VIN Operating Supply Current		All drivers driven, I <sup>2</sup> C serial interface idle		19.2	31.5	mA
VIN Sleep Supply Current		I <sup>2</sup> C serial interface idle, SLEEP = 1		2.9	4.2	mA
VIN Shutdown Supply Current		EN = 0, all digital inputs = VDD or GND		0.1	2	μA
VDD Regulation Voltage			2.25	2.5	2.75	V
Input High Voltage PWM0 - PWM3, SCL, SDA			0.7 x VDD			V
Input Low Voltage PWM0 - PWM3, SCL, SDA					0.3 x VDD	V
EN Input High Voltage			1.9			
EN Input Low Voltage					1.0	V
EN Input Hysteresis				150		mV
SDA, FLTB Output Low Voltage		Sinking 3mA			0.5	V
Open Circuit String Fault Detect Voltage	OC <sub>REF</sub>			6		V
Short Circuit String Fault Detect Voltage	SC <sub>REF</sub>			6		V
D0 - D3 Leakage Current		Voltage under 9V		0.1		μA
		Voltage between 9V to 16V			5	μA
G0 - G3 Maximum Gate Drive Voltage			9.0	9.6	10.2	V
G0 - G3 Gate Drive Current		PWMn = VDD; Sn = GND; Gn = GND		109		mA
G0 - G3 Gate Sink Current		PWMn = GND; Gn = 9.6V		-18		mA
Current Sense Regulation Voltage		ISTR0 = 0xFF; T <sub>A</sub> = 25°C	465	490	498.75	mV
		ISTR0 = 0xFF; T <sub>A</sub> = 85°C	455.7		524.3	mV
		ISTR0 = 0x7F; T <sub>A</sub> = 25°C	242.5	250	257.5	mV
		ISTR0 = 0x7F; T <sub>A</sub> = 85°C	235		265	mV
String-to-String Current Matching		ISTR0 = 0x7F; T <sub>A</sub> = 25°C		0.50	±2.2	%
		ISTR0 = 0x7F; T <sub>A</sub> = -40°C to +85°C		0.75	±3.2	%
Thermal Cut-Off temperature				135		°C
FBI <sub>n</sub> to FBO <sub>n</sub> Current Transfer Error		FBI <sub>n</sub> = 100uA		±2		%
FBO <sub>n</sub> Current Step-Size				1.1		μA
FBO <sub>n</sub> Feedback Output Current Maximum		Compliance voltage 3.5V minimum	210			μA

PARAMETER	SYMBOL	CONDITIONS	MIN	TYP	MAX	UNIT
<b>AC ELECTRICAL CHARACTERISTICS</b>						
PWM Frequency	f <sub>PWM</sub>	(Note 7)	0		50,000	Hz
PWM Duty Cycle		(Note 7)	0		100	%



# Atmel LED Drivers-MSL2041/MSL2042

Low-cost, Simple 4-string LED Drivers with External Current Sink MOSFETs, 5000:1 Dimming Range and Per String PWM Input

PARAMETER	SYMBOL	CONDITIONS	MIN	TYP	MAX	UNIT
<b>I<sup>2</sup>C SWITCHING CHARACTERISTICS</b>						
SCL Clock Frequency	$1/t_{SCL}$	Bus timeout disabled (Note 1)	0		1,000	kHz
STOP to START Condition Bus Free Time	$t_{BUF}$		0.5			$\mu$ s
Repeated START Condition Hold Time	$t_{HD:STA}$		0.26			$\mu$ s
Repeated START Condition Setup Time	$t_{SU:STA}$		0.26			$\mu$ s
STOP Condition Setup Time	$t_{SU:STOP}$		0.26			$\mu$ s
SDA Data Hold Time	$t_{HD:DAT}$		5			ns
SDA Data Valid Acknowledge Time	$t_{VD:ACK}$	(Note 2)	0.05		0.55	$\mu$ s
SDA Data Valid Time	$t_{VD:DAT}$	(Note 3)	0.05		0.55	$\mu$ s
SDA Data Set-Up Time	$t_{SU:DAT}$		100			ns
SCL Clock Low Period	$t_{LOW}$		0.5			$\mu$ s
SCL Clock High Period	$t_{HIGH}$		0.26			$\mu$ s
SDA, SCL Fall Time	$t_F$	(Note 4, Note 5)			120	ns
SDA, SCL Rise Time	$t_R$				120	ns
SDA, SCL Input Suppression Filter Period	$t_{SP}$	(Note 6)		50		ns

Note 1. Minimum SCL clock frequency is limited by the bus timeout feature, which resets the serial bus interface if either SDA or SCL is held low for

$t_{TIMEOUT}$   
Note 2.  $t_{VD:ACK}$  = SCL LOW to SDA (out) LOW acknowledge time.

Note 3.  $t_{VD:DAT}$  = minimum SDA output data-valid time following SCL LOW transition.

Note 4. A master device must internally provide an SDA hold time of at least 300ns to ensure an SCL low state.

Note 5. The maximum SDA and SCL rise times is 300ns. The maximum SDA fall time is 250ns. This allows series protection resistors to be connected between SDA and SCL inputs and the SDA/SCL bus lines without exceeding the maximum allowable rise time.

Note 6. MSL2041/2 includes input filters on SDA and SCL that suppress noise less than 50ns.

Note 7. Parameter is guaranteed by design and not production tested.



## Block Diagram

Figure 1. Atmel LED Drivers-MSL2041/2 Block Diagram

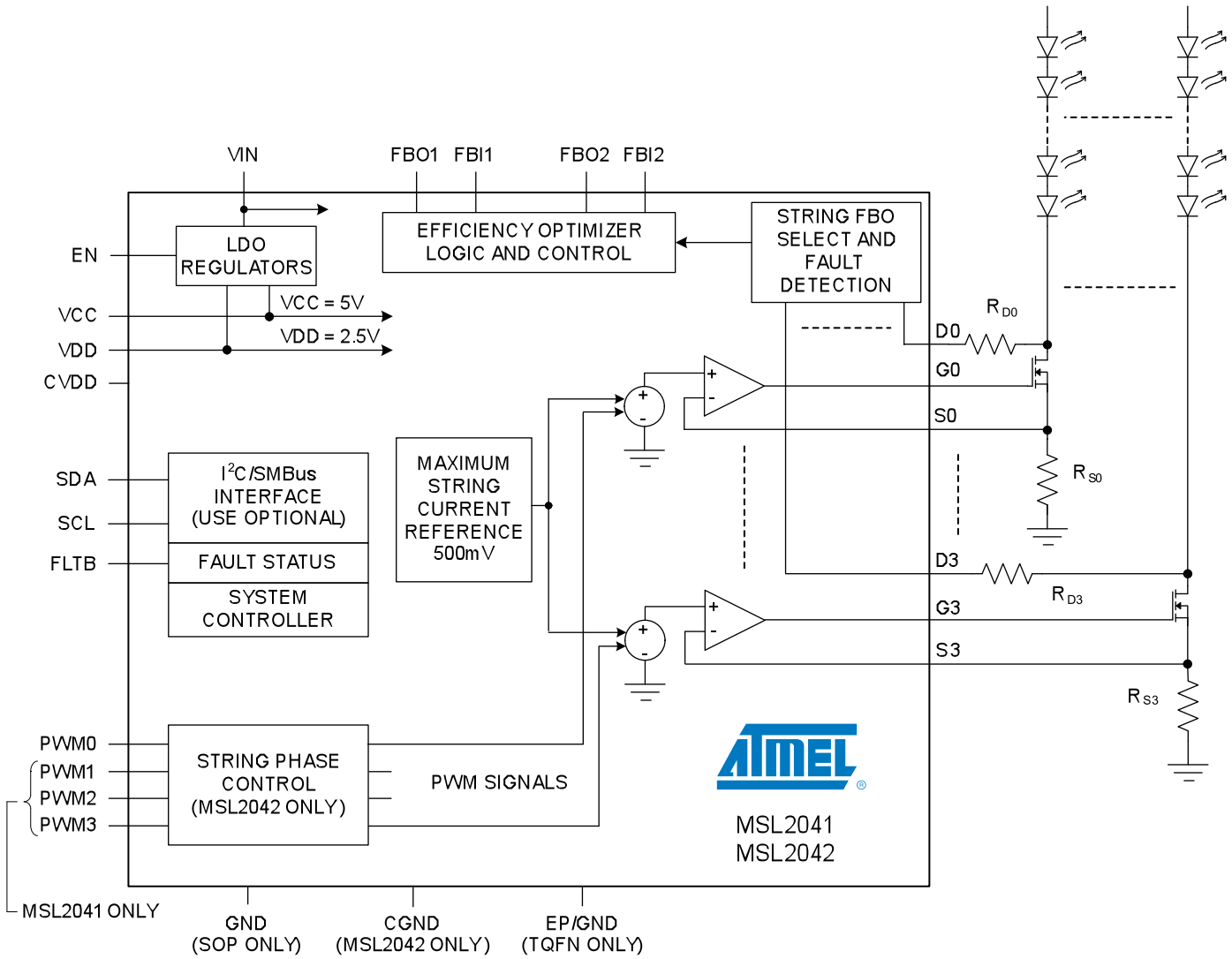

# Atmel LED Drivers-MSL2041/MSL2042

Low-cost, Simple 4-string LED Drivers with External Current Sink MOSFETs, 5000:1 Dimming Range and Per String PWM Input

## Typical Application Circuit

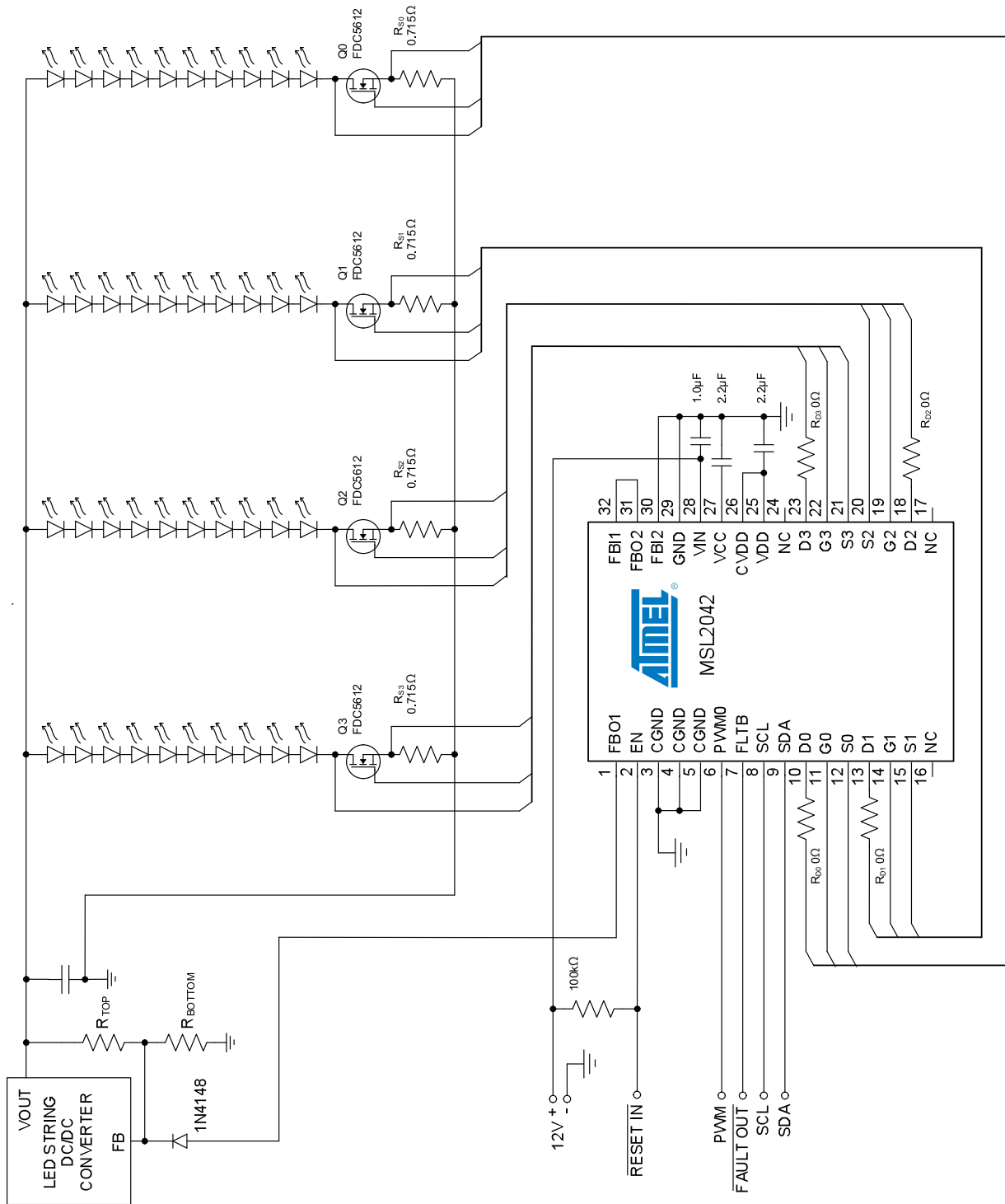

Figure 2. Atmel LED Drivers-MSL2042 driving four LED strings at 350mA peak current per string, controlling a single power supply



## Detailed Description

The MSL2041 and MSL2042 are highly integrated, flexible, four-string LED drivers that use external MOSFETs to allow high string currents, and include power supply control to maximize efficiency of up to two external string power supplies. Optimized for stand-alone operation they require only external PWM signal(s), a few external components (including the string drive N-Channel MOSFETs) and an external string power supply. The MSL2041/2s four MOSFET gate drive outputs, G0 - G3, are optimized to drive FETs with a maximum gate voltage threshold of 3V.

The MSL2041/2 LED drivers provide simple control of LED brightness through both peak current and external PWM drive controls. Peak current control, set by external FET source resistors, offers excellent color consistency, while pulse width control allows simple brightness management. Multiple devices easily connect together to drive more than four LED strings while maintaining optimum system efficiency. An active low fault output activates when either a string open circuit or an LED short circuit condition is detected and verified. The MSL2041/2 are intended for stand-alone operation but offer additional string control and monitoring through a 1MHz I<sup>2</sup>C/SMBus compatible serial interface. Use of the serial interface is not required for operation.

The MSL2041 offers four PWM inputs that directly control the four string drive outputs, while the MSL2042 requires only a single PWM input signal and features automatic, progressive phase spreading of the four string drive signals. With phase spreading a ¼ PWM frame time delay is calculated and applied progressively to the string drive signals. Phase spreading helps reduce both the transient load on the LED power supply, and the power supply output capacitor size requirement.

The Adaptive SourcePower Efficiency Optimizer (EO) outputs control a wide range of different architectures of external DC/DC and AC/DC converters. Multiple drivers in a system communicate with each other in real time to select an optimized operating voltage for the LEDs. The EO allows design of the power supply for the worst case Forward Voltage ( $V_f$ ) of the LEDs without worrying about excessive power dissipation issues, while ensuring that the LED drive system is operating at optimum

efficiency. During start-up the EO automatically reduces the string power supply voltage to the minimum value required to keep the LEDs in current regulation. The EO periodically performs re-optimization to compensate for changes of the LED's forward voltage, and to assure continued optimum power savings. Additionally, all string drivers are continually monitored for proper operation, and if any of the LED strings become starved for current the Efficiency Optimizer automatically increases the string power supply voltage to bring the string back in to current regulation.

### Setting the Maximum LED String Current with the FET Source Resistor $R_s$

The maximum string current,  $I_{LED}$ , for each string is set by a shunt resistor,  $R_s$ , connected to ground from the source terminal of the string drive MOSFET (Figure 1, page 6). Determine the resistor value using

$$R_s = \left( \frac{127}{255} \right) * \left( \frac{0.50196}{I_{LED}} \right) \Omega$$

(where 127 is the default value of ISTR, String Current Control register 0x0E). For example, a full-scale LED current of 350mA returns  $R_s = 0.715\Omega$  (to the nearest 1% resistor value).

### LED String Fault Response

The MSL2041/2 monitor the LED strings to detect LED short-circuit and string open-circuit faults (Figure 3). When verified, all string faults force the open drain fault output FLTBLow.

After power-up, when shorted LEDs are verified in a string the string is disabled and no longer monitored by the Efficiency Optimizer. The short circuit threshold is 6V (typical) and the additive voltage drop lost from the shorted LEDs, plus the headroom required for the external FET, must be equal to or greater than the 6V threshold to generate a fault. Typically, two LEDs in a string must be shorted to cause a short circuit fault,

# Atmel LED Drivers-MSL2041/MSL2042

Low-cost, Simple 4-string LED Drivers with External Current Sink MOSFETs, 5000:1 Dimming Range and Per String PWM Input

but because LEDs differ, the number of shorted LEDs required to generate a fault varies. The current fold-back option, available through the serial interface, slightly changes the fault response when an LED short circuit event is suspected.

A string with an open circuit LED is off by default, and when this situation is verified the faulty string is disabled and no longer monitored by the Efficiency Optimizer.

Toggle EN low and then high clears all faults and the MSL2041/2 begin to control and monitor all strings as if experiencing an initial power-up. Fault conditions that persist re-establish fault responses.

Faulty strings are flagged in the fault registers. When using the serial interface, fault conditions are typically read in response to FLTB pulling low.

## Over Temperature Shutdown

The MSL2041/2 includes an automatic over-temperature shutdown. If the die temperature exceeds 135°C, the device turns off, just as if the enable input EN is forced low. When the die temperature drops below 120°C the device wakes up again and turns on as if experiencing an initial power-up.

## Connecting the Efficiency Optimizer to an LED String Power Supply and Selecting Resistors

The MSL2041/2 are designed to control LED string power supplies that use a voltage divider ( $R_{TOP}$  and  $R_{BOTTOM}$  in Figure 4) to set output voltage, and whose regulation feedback voltage is not more than  $3.5V - V_F$ . The Efficiency Optimizer improves power efficiency by injecting a current of between 0µA and 280.5µA into the voltage divider of the external power supply, dynamically adjusting the power supply's output to the minimum voltage required by the LED strings.

Each of the two EOs monitors two LED strings. Strings zero and one are assigned to FBO1, and strings two and three are assigned to FBO2 (Table 1). When a single supply is used for all four strings connect FBO2 to FBI1 (Figure 4), as explained in the next section "Using Multiple EOs/Devices to Control a Common Power Supply". The MSL2041/2 then automatically maximizes efficiency for all strings. When two supplies are used, connect FBO1 to the supply powering strings zero and one, and connect FBO2 to the supply powering strings two and three (Figure 5). For clarity, Figure 4 and Figure 5 do not show the Source and Drain connections between the devices and the MOSFETs.

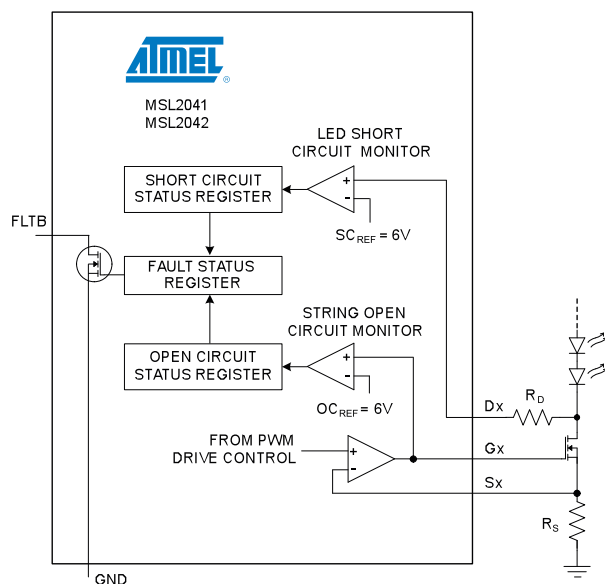
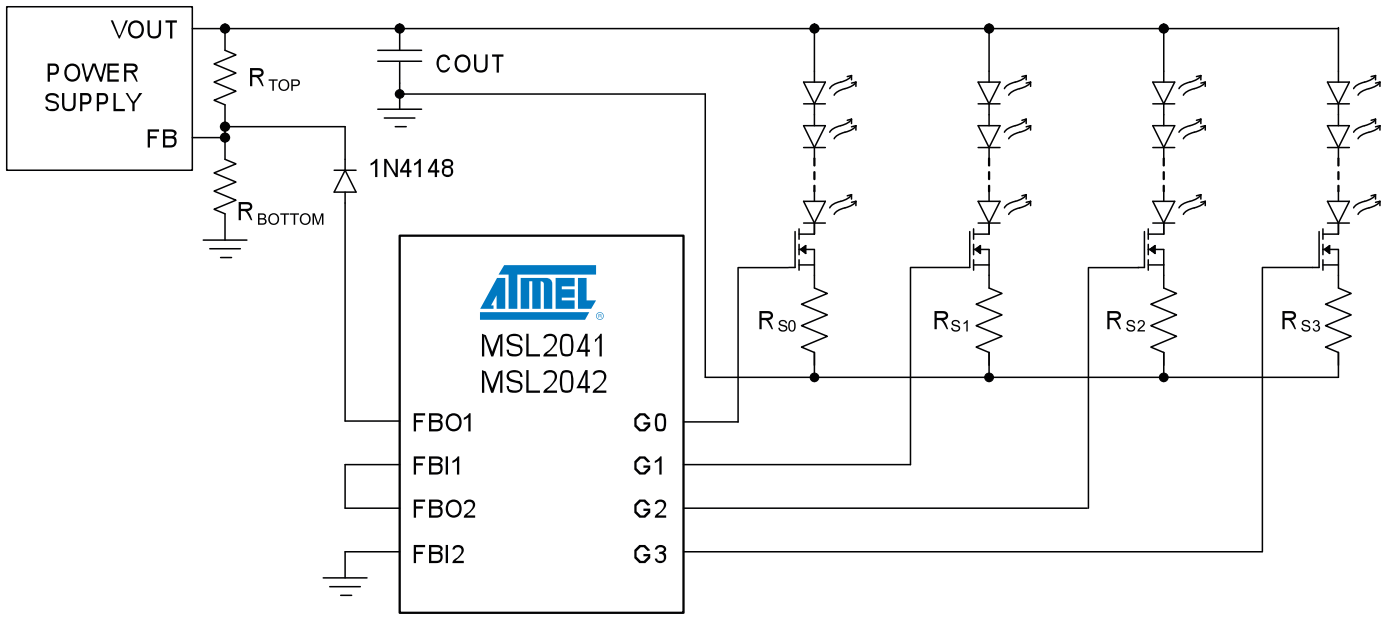

Figure 3. Open-circuit and Short-circuit Detection Block Diagram



**Table 1. String EO Assignments**



**Figure 4. EO Configuration When Using a Single String Power Supply**

# Atmel LED Drivers-MSL2041/MSL2042

Low-cost, Simple 4-string LED Drivers with External Current Sink MOSFETs, 5000:1 Dimming Range and Per String PWM Input

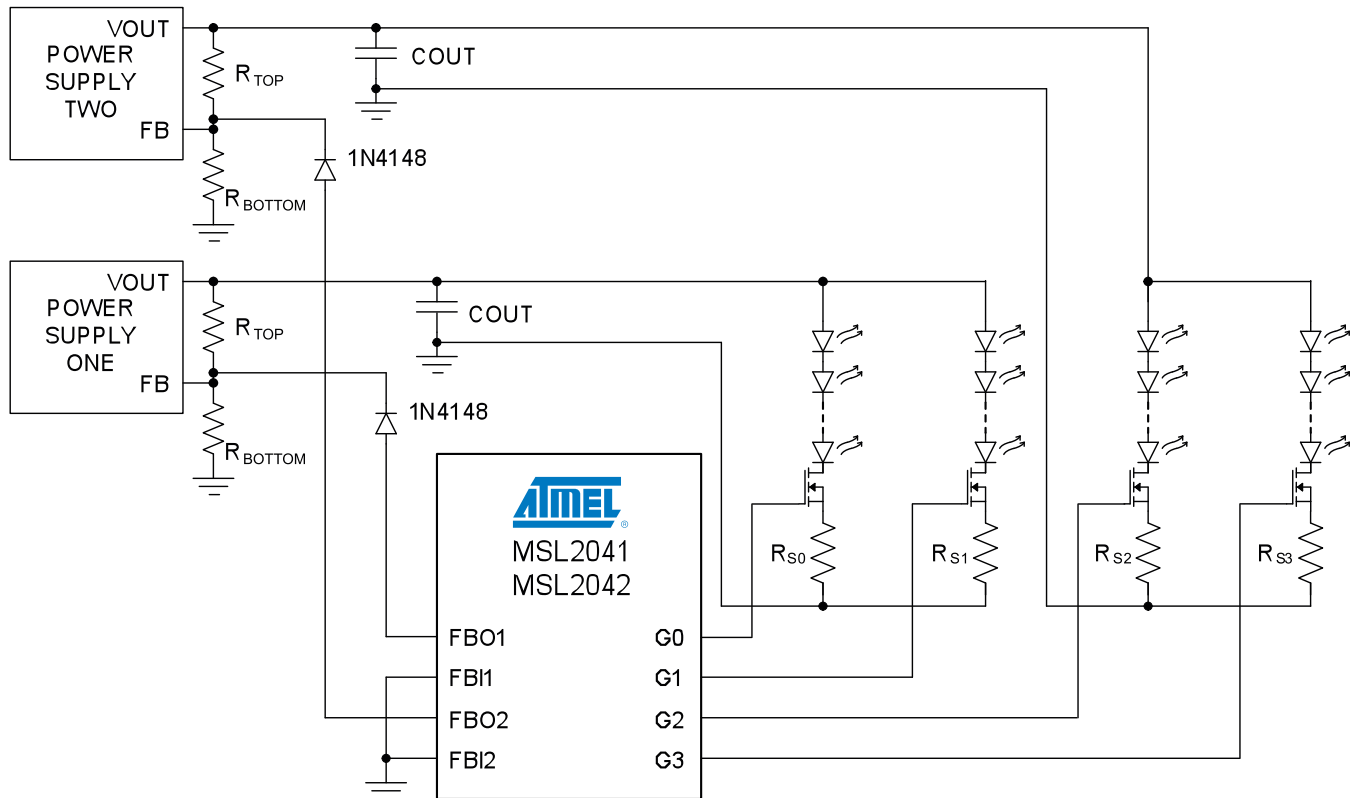

Figure 5. EO Configuration When Using Two String Power Supplies



To select  $R_{TOP}$  and  $R_{BOTTOM}$  first determine  $V_{OUT(MIN)}$  and  $V_{OUT(MAX)}$ , the minimum and maximum string supply voltage limits, using:

$$V_{OUT(MIN)} = (V_{f(MIN)} * [\#ofLEDs]) + 0.5 ,$$

and

$$V_{OUT(MAX)} = (V_{f(MAX)} * [\#ofLEDs]) + 0.5 ,$$

where  $V_{f(MIN)}$  and  $V_{f(MAX)}$  are the LED's minimum and maximum forward voltage drops at the peak current set by  $R_S$ . For example, if the LED data are  $V_{f(MIN)} = 3.5V$  and  $V_{f(MAX)} = 3.8V$ , and ten LEDs are used in a string, then the total minimum and maximum voltage drop across a string is 35V and 38V. Adding an allowance of 0.5V for the string drive MOSFET headroom brings  $V_{OUT(MIN)}$  to 35.5V and  $V_{OUT(MAX)}$  to 38.5V. Then determine  $R_{TOP}$  using:

$$R_{TOP} = \frac{V_{OUT(MAX)} - V_{OUT(MIN)}}{I_{FBO n(MAX)}} ,$$

where  $I_{FBO n(MAX)}$  is the 280.5µA maximum output current of the Efficiency Optimizer outputs FBO<sub>n</sub> (280.5µA = 1.1µA \* 255, the current per LSB of the FBO DAC times the maximum DAC count). Finally, determine  $R_{BOTTOM}$  using:

$$R_{BOTTOM} = R_{TOP} * \frac{V_{FB}}{V_{OUT(MAX)} - V_{FB}} ,$$

where  $V_{FB}$  is the regulation feedback voltage of the power supply. Place a diode ( 1N4148 or similar) between FBO<sub>n</sub> and the supply's feedback node to protect the MSL2041/2 against current flow into FBO<sub>n</sub>.

Once configured, determine the change in power supply output voltage in response to a change in FBO<sub>n</sub> output current using:

$$\Delta V_{OUT} = \Delta I_{FBO n} * R_{TOP} .$$

Assure that the power supply settling time for a voltage step size of  $1.1\mu A * R_{TOP}$  is less than the 4ms EO Step-hold duration time.

## Using Multiple EOs/Devices to Control a Common Power Supply

Cascade multiple Efficiency Optimizers (EOs), either within the same device or across multiple devices, into a chain configuration (Figure 6), with the FBIn of one EO connected to the FBO<sub>n</sub> of the next. Connect the first FBO<sub>n</sub> to the power supply feedback resistor node through a diode ( 1N4148 or similar) placed close to the power supply feedback node, and unused FBIn inputs to ground as close to the MSL2041/2 as possible. The chained EOs work together to ensure that the system operates at optimum efficiency. Note that the accuracy of the feedback chain may degrade through each link of the FBIn/FBO<sub>n</sub> chain by 2% (typical). Derate the maximum FBO<sub>n</sub> current using:

$$I_{FBO n(MAX / MIN)} = 280.5\mu A * (0.98)^{N-1} ,$$

where N is the number of EOs connected in series. Use  $I_{FBO n(MAX/MIN)}$  in the above  $R_{TOP}$  resistor equation for the term  $I_{FBO n(MAX)}$  instead of using 280.5µA.

Take care in laying out the traces for the Efficiency Optimizer connections. Minimize the FBIn/FBO<sub>n</sub> trace lengths as much as possible. Do not route the signals close to traces with large variations in voltage or current, because noise may couple into FBIn. If these traces must be routed near noisy signals, shield them from noise by using ground planes or guard traces. For clarity, Figure 6 shows Source and Drain connections only for unused outputs 2 and 3 of device two. Note that because of the interplay between EOs and the automatic fault response behavior, when both strings monitored by a single EO fault and turn off, that the string supply is forced to its maximum value and all remaining active strings typically detect short circuit faults and also turn off.



# Atmel LED Drivers-MSL2041/MSL2042

Low-cost, Simple 4-string LED Drivers with External Current Sink MOSFETs, 5000:1 Dimming Range and Per String PWM Input

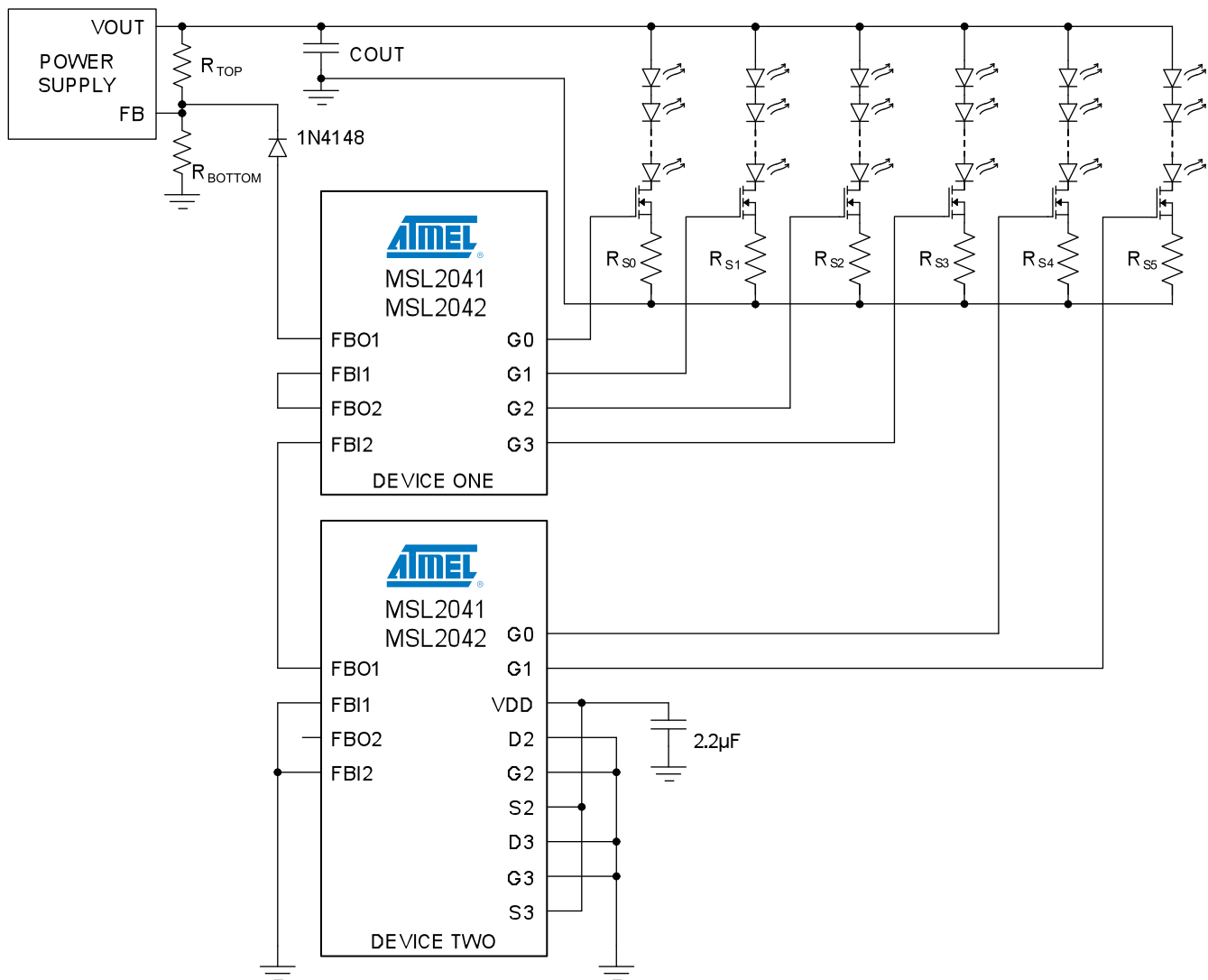

Figure 6. EO Chain Configuration of Two Devices, Six Strings and a Single String Power Supply



## Choosing the Drain Resistor $R_D$

The drain resistor  $R_D$  connects the MSL2041/2 to the Drain of the external MOSFET. Choose  $R_D$  using:

$$R_D = \left( \frac{V_{OUT(MAX)} - N(V_{F(DARK)}) - 22.5}{I_{DARK}} \right) - 1 \times 10^5 \Omega,$$

where  $V_{OUT(MAX)}$  is the value calculated above in the section "Connecting the Efficiency Optimizer to an LED String Power Supply and Selecting Resistors" beginning on page 12.  $N$  is the number of LEDs in the string,  $I_{DARK}$  is the maximum allowable string off current and  $V_{F(DARK)}$  is the LED forward voltage drop at  $I_{DARK}$ . When the value calculated for  $R_D < 0$  use  $0\Omega$ .

LED manufacturers typically do not publish  $I_{DARK}$  and  $V_{F(DARK)}$  information. One way to determine these numbers is to use the following method.

Set up the test circuit of Figure 7. Adjust  $R_1$  until the current meter indicates  $I_{DARK}$  (choose  $I_{DARK} < 1\text{mA}$ ). Use a volt meter to measure the voltage at the anode of the LED (A), and then at the cathode of the LED (B). Subtract the voltage measured at B from that measured at A to determine  $V_{F(DARK)}$ . Some typical values determined using this method are listed in Table 2.

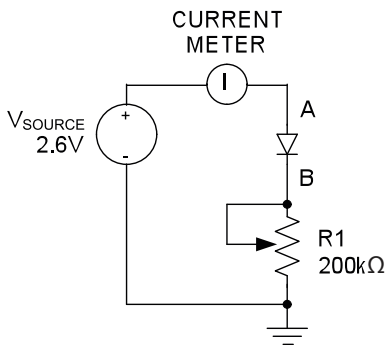

Figure 7. Test Circuit for Determining  $V_{F(DARK)}$

Table 2. Some Typical  $I_{DARK}$  and  $V_{F(DARK)}$  Values Determined Using Figure 7

LED TYPE	LED PART #	$I_{DARK}$ ( $\mu\text{A}$ )	$V_{F(DARK)}$ (V)
LOW POWER	LW Y1SG	1.72	2.285
MEDIUM POWER	LW G6SP	1.67	2.276
HIGH POWER	LXLW-PWC1	1.72	2.195

Large values of  $R_D$  may cause false LED short circuit faults. Discharge of the parasitic capacitance at the Dn node through a large  $R_D$  holds the node above the string fault threshold for longer than the LED short circuit verification time. The addition of a feed-forward capacitor,  $C_{FF}$  in Figure 8, mitigates this issue. The value for  $C_{FF}$  depends upon the amount of parasitic capacitance at the Dn node and the size of  $R_D$ , but  $C_{FF} = 15\text{pF}$  is an appropriate first approximation.

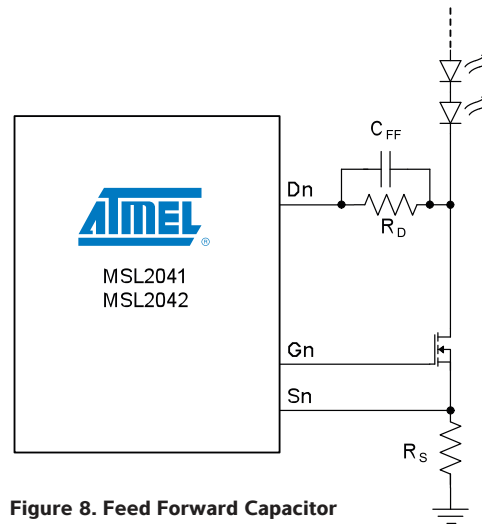

Figure 8. Feed Forward Capacitor

# Atmel LED Drivers-MSL2041/MSL2042

Low-cost, Simple 4-string LED Drivers with External Current Sink MOSFETs, 5000:1 Dimming Range and Per String PWM Input

## Direct PWM Control of the LED Strings

An external PWM signal applied to the inputs PWM0 - PWM3 (MSL2041) or PWM0 (MSL2042) allows direct control over the strings frequency and duty cycle. The PWM inputs recognize signals of DC to 50kHz, and 0% to 100% duty cycle. The MSL2042, which allows only a single PWM input, calculates and applies a progressive delay of 1/4<sup>th</sup> the PWM frame successively to strings one - three, while string zero follows the PWM input directly.

## Register Map Summary

Control the MSL2041/2 using the registers in the range 0x00 - 0x18. Register bit values always revert to their default values (Table 4) when EN is taken high. Do not write to registers not listed in Table 3.

**Table 3. Register Map**

ADDRESS AND REGISTER NAME		FUNCTION	REGISTER DATA							
			D7	D6	D5	D4	D3	D2	D1	D0
0x00	STRINGEN	LED String Enable	-	-	-	-	STR3EN	STR2EN	STR1EN	STR0EN
0x01		UNUSED								
0x02	CONFIG	Configuration	FLDBKEN	I <sup>2</sup> CTOEN	-	-	STRSCFEN	STROCFEN	FBOEN	SLEEP
0x03	FLTSTATUS*	Fault Status	-	-	-	-	STRSCDET	STROCDDET	-	FLTBDRV
0x04 - 0x07		UNUSED								
0x08	FLTMASK	String Fault Enable	-	-	-	-	FLTMASK3	FLTMASK2	FLTMASK1	FLTMASK0
0x09	SCSTAT*	LED Short Circuit Fault	-	-	-	-	SC3	SC2	SC1	SC0
0x0A	OCSTAT*	String Open Circuit Fault	-	-	-	-	OC3	OC2	OC1	OC0
0x0B - 0x0D		UNUSED								
0x0E	ISTR	8-Bit Global String Current	ISTR[7:0]							
0x0F		UNUSED								
0x10	RESERVED	Must Be 0x04	0	0	0	0	0	1	0	0
0x11	FBOCTRL	Efficiency Optimizer Control	FBOSTEP[1:0]		HDRMSTEP[1:0]		-	-	ACALEN	ICHKDIS
0x12 - 0x13		UNUSED								
0x14	FBODAC1*	Efficiency Optimizer DAC Readback	FBODAC1[7:0]							
0x15	FBODAC2*		FBODAC2[7:0]							
0x16 - 0x17		UNUSED								
0x18	FBOSTAT*	FBO Status	-	-	FBIGNDSTAT[1:0]		-	-	-	-

\* Read Only Registers



## Register Power-up Defaults

Register power-up default values are shown in Table 4.

**Table 4. Register Power-up Defaults**

REGISTER NAME AND ADDRESS		POWER-UP CONDITION REGISTERS INITIALIZED FROM E <sup>2</sup> PROM	REGISTER DATA								
			D7	D6	D5	D4	D3	D2	D1	D0	HEX
0x00	STRINGEN	All Four LED String Drive Outputs Enabled	0	0	0	0	1	1	1	1	0F
0x02	CONFIG	Device Awake Efficiency Optimizer Outputs Enabled String Open Circuit Detection Enabled LED Short Circuit Detection Enabled I <sup>2</sup> C Timeout Enabled String Current Fold-Back Disabled	0	1	0	0	1	1	1	0	4E
0x08	FLTMASK	All Four Strings Monitored for Faults	0	0	0	0	1	1	1	1	0F
0x0E	ISTR	Global String Peak Current is ½ its Programmable Value	0	1	1	1	1	1	1	1	7F
0x10	RESERVED	0x04	0	0	0	0	0	1	0	0	04
0x11	FBOCTRL	MOSFET Current Sink Error Detection Enabled Efficiency Optimizer Auto-Recalibration Enabled Efficiency Optimizer Initial Calibration Step Size = 1 LSBs Efficiency Optimizer Headroom Correction Step Size = 1 LSBs	0	0	0	1	0	0	1	0	1A

### Atmel Corporation

2325 Orchard Parkway  
San Jose, CA 95131  
USA

**Tel:** (+1)(408) 441-0311

**Fax:** (+1)(408) 487-2600

www.atmel.com

### Atmel Asia Limited

Unit 01-5 & 16, 19F  
BEA Tower, Millennium City 5  
418 Kwun Tong Road  
Kwun Tong, Kowloon  
HONG KONG

**Tel:** (+852) 2245-6100

**Fax:** (+852) 2722-1369

### Atmel Munich GmbH

Business Campus  
Parking 4  
D-85748 Garching b. Munich  
GERMANY

**Tel:** (+49) 89-31970-0

**Fax:** (+49) 89-3194621

### Atmel Japan

9F, Tonetsu Shinkawa Bldg.  
1-24-8 Shinkawa  
Chuo-ku, Tokyo 104-0033  
JAPAN

**Tel:** (+81)(3) 3523-3551

**Fax:** (+81)(3) 3523-7581

© 2011 Atmel Corporation. All rights reserved. / Rev.: MEM-MSL2041/42DB1-E-US\_06-11

Atmel®, logo and combinations thereof, and others are registered trademarks or trademarks of Atmel Corporation or its subsidiaries. Other terms and product names may be trademarks of others.

Disclaimer: The information in this document is provided in connection with Atmel products. No license, express or implied, by estoppel or otherwise, to any intellectual property right is granted by this document or in connection with the sale of Atmel products. EXCEPT AS SET FORTH IN THE ATMEL TERMS AND CONDITIONS OF SALES LOCATED ON THE ATMEL WEBSITE, ATMEL ASSUMES NO LIABILITY WHATSOEVER AND DISCLAIMS ANY EXPRESS, IMPLIED OR STATUTORY WARRANTY RELATING TO ITS PRODUCTS INCLUDING, BUT NOT LIMITED TO, THE IMPLIED WARRANTY OF MERCHANTABILITY, FITNESS FOR A PARTICULAR PURPOSE, OR NON-INFRINGEMENT. IN NO EVENT SHALL ATMEL BE LIABLE FOR ANY DIRECT, INDIRECT, CONSEQUENTIAL, PUNITIVE, SPECIAL OR INCIDENTAL DAMAGES (INCLUDING, WITHOUT LIMITATION, DAMAGES FOR LOSS AND PROFITS, BUSINESS INTERRUPTION, OR LOSS OF INFORMATION) ARISING OUT OF THE USE OR INABILITY TO USE THIS DOCUMENT, EVEN IF ATMEL HAS BEEN ADVISED OF THE POSSIBILITY OF SUCH DAMAGES. Atmel makes no representations or warranties with respect to the accuracy or completeness of the contents of this document and reserves the right to make changes to specifications and products descriptions at any time without notice. Atmel does not make any commitment to update the information contained herein. Unless specifically provided otherwise, Atmel products are not suitable for, and shall not be used in, automotive applications. Atmel products are not intended, authorized, or warranted for use as components in applications intended to support or sustain life.