

# IPS521/IPS521S

## FULLY PROTECTED HIGH SIDE POWER MOSFET SWITCH

### Features

- Over temperature protection (with auto-restart)
- Short-circuit protection (current limit)
- Active clamp
- E.S.D protection
- Status feedback
- Open load detection
- Logic ground isolated from power ground

### Product Summary

$R_{ds(on)}$	80m $\Omega$ (max)
$V_{clamp}$	50V
I Limit	10A
$V_{open\ load}$	3V

### Description

The IPS521/IPS521S are fully protected five terminal high side switches with built in short-circuit , over-temperature, ESD protection, inductive load capability and diagnostic feedback. The output current is controlled when it reaches  $I_{lim}$  value. The current limitation is activated until the thermal protection acts. The over-temperature protection turns off the high side switch if the junction temperature exceeds  $T_{shutdown}$ . It will automatically restart after the junction has cooled 7°C below  $T_{shutdown}$ . A diagnostic pin is provided for status feedback of short-circuit, over-temperature and open load detection. The double level shifter circuitry allows large offsets between the logic ground and the load ground.

### Truth Table

Op. Conditions	In	Out	Dg
Normal	H	H	H
Normal	L	L	L
Open load	H	H	H
Open load	L	H	H
Over current	H	L (limiting)	L
Over current	L	L	L
Over-temperature	H	L (cycling)	L
Over-temperature	L	L	L

### Typical Connection

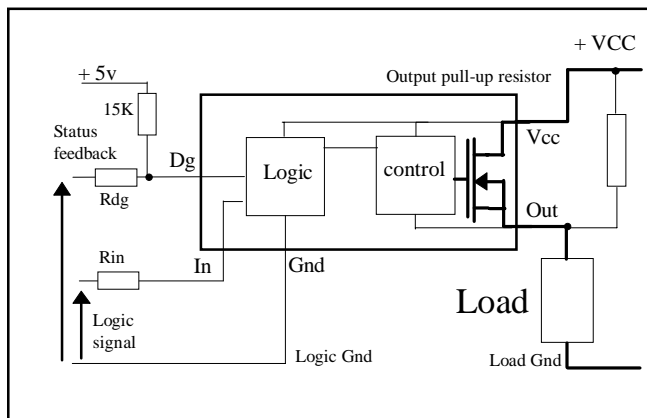

### Packages

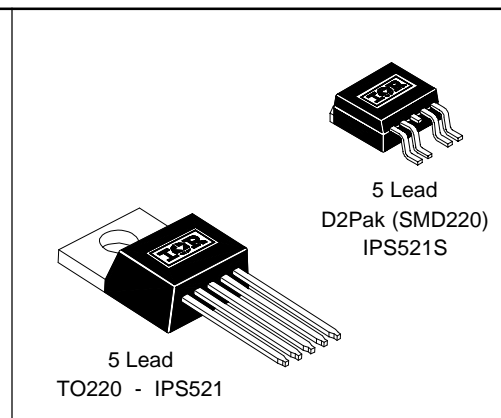

## Absolute Maximum Ratings

Absolute maximum ratings indicate sustained limits beyond which damage to the device may occur. All voltage parameters are referenced to GROUND lead. (T<sub>j</sub> = 25°C unless otherwise specified).

Symbol	Parameter	Min.	Max.	Units	Test Conditions
V <sub>out</sub>	Maximum output voltage	V <sub>CC</sub> -50	V <sub>CC</sub> +0.3		
V <sub>offset</sub>	Maximum logic ground to load ground offset	V <sub>CC</sub> -50	V <sub>CC</sub> +0.3		
V <sub>in</sub>	Maximum Input voltage	-0.3	7		
I <sub>in, max</sub>	Maximum positive IN current	-5	10	mA	
V <sub>dg</sub>	Maximum diagnostic output voltage	-0.3	7	V	
I <sub>dg, max</sub>	Maximum diagnostic output current	-1	10	mA	
I <sub>sd cont.</sub>	Diode max. permanent current <sup>(1)</sup> (r <sub>th</sub> =62°C/W)	—	2.2		
I <sub>sd pulsed</sub>	Diode max. pulsed current <sup>(1)</sup>	—	10		
ESD1	Electrostatic discharge voltage (Human Body)	—	4		C=100pF, R=1500Ω,
ESD2	Electrostatic discharge voltage (Machine Model)	—	0.5		C=200pF, R=0Ω, L=10μH
P <sub>d</sub>	Maximum power dissipation <sup>(1)</sup> (TC=25°C) IPS521	—	40		
	(TC=25°C) IPS521S	—	1.56		
T <sub>j max.</sub>	Max. storage & operating junction temp.	-40	+150	°C	
T <sub>lead</sub>	Lead temperature (soldering 10 seconds)	—	300		
V <sub>cc max.</sub>	Maximum V <sub>cc</sub> voltage	—	50	V	

## Thermal Characteristics

Symbol	Parameter	Min.	Typ.	Max.	Units	Test Conditions
R <sub>th 1</sub>	Thermal resistance junction to case	—	3			
R <sub>th 2</sub>	Thermal resistance junction ambient	—	60			
R <sub>th 1</sub>	Thermal resistance with standard footprint	—	60			
R <sub>th 2</sub>	Thermal resistance with 1" square footprint	—	35			D <sup>2</sup> PAK (SMD220)
R <sub>th 3</sub>	Thermal resistance junction to case	—	3			

(1) Limited by junction temperature (pulsed current limited also by internal wiring)

### Recommended Operating Conditions

These values are given for a quick design. For operation outside these conditions, please consult the application notes.

Symbol	Parameter	Min.	Max.	Units
V <sub>CC</sub>	Continuous V <sub>CC</sub> voltage	5.5	35	
V <sub>IH</sub>	High level input voltage	4	5.5	
V <sub>IL</sub>	Low level input voltage	-0.3	0.9	
I <sub>out</sub>	Continuous output current (T <sub>amb</sub> = 85°C, T <sub>j</sub> = 125°C, R <sub>th</sub> = 60°C/W, ) IPS521	—	2.2	
I <sub>out</sub>	Continuous output current (T <sub>amb</sub> = 85°C, T <sub>j</sub> = 125°C, R <sub>th</sub> = 80°C/W, ) IPS521S	—	1.9	
R <sub>in</sub>	Recommended resistor in series with IN pin	4	6	
R <sub>dg</sub>	Recommended resistor in series with DG pin	10	20	

### Static Electrical Characteristics

(T<sub>j</sub> = 25°C, V<sub>CC</sub> = 14V unless otherwise specified.)

Symbol	Parameter	Min.	Typ.	Max.	Units	Test Conditions
R <sub>ds(on)</sub> @T <sub>j</sub> =25°C	ON state resistance T <sub>j</sub> = 25°C	—	55	80		V <sub>in</sub> = 5V, I <sub>out</sub> = 5A
R <sub>ds(on)</sub> (V <sub>CC</sub> =6V)	ON state resistance @ V <sub>CC</sub> = 6V	—	55	80		V <sub>in</sub> = 5V, I <sub>out</sub> = 2.5A
R <sub>ds(on)</sub> @T <sub>j</sub> =150°C	ON state resistance T <sub>j</sub> = 150°C	—	110	140		V <sub>in</sub> = 5V, I <sub>out</sub> = 5A
V <sub>CC oper.</sub>	Operating voltage range	5.5	—	35		
V clamp 1	V <sub>CC</sub> to OUT clamp voltage 1	50	55	—		I <sub>d</sub> = 10mA (see Fig.1 & 2)
V clamp 2	V <sub>CC</sub> to OUT clamp voltage 2	—	56	65		I <sub>d</sub> = I <sub>sd</sub> (see Fig.1 & 2)
V <sub>f</sub>	Body diode forward voltage	—	0.9	1.2		I <sub>d</sub> = 2.5A, V <sub>in</sub> = 0V
I <sub>CC off</sub>	Supply current when OFF	—	16	50	μA	V <sub>in</sub> = 0V, V <sub>out</sub> = 0V
I <sub>CC on</sub>	Supply current when ON	—	0.6	2	mA	V <sub>in</sub> = 5V
I <sub>CC ac</sub>	Ripple current when ON (AC RMS)	—	20	—	μA	V <sub>in</sub> = 5V
V <sub>dg1</sub>	Low level diagnostic output voltage	—	0.15	0.4	V	I <sub>dg</sub> = 1.6 mA
I <sub>oh</sub>	Output leakage current	—	50	120		V <sub>out</sub> = 6V
I <sub>ol</sub>	Output leakage current	0	—	25		V <sub>out</sub> = 0V
I <sub>dg</sub> leakage	Diagnostic output leakage current	—	—	10		V <sub>dg</sub> = 5.5V
V <sub>ih</sub>	IN high threshold voltage	—	2.2	3		
V <sub>il</sub>	IN low threshold voltage	1	1.9	—		
I <sub>in, on</sub>	On state IN positive current	—	70	200	μA	V <sub>in</sub> = 5V
I <sub>n hyst</sub>	Input hysteresis	0.1	0.25	0.5	V	

## Switching Electrical Characteristics

$V_{CC} = 14V$ , Resistive Load =  $2.8\Omega$ ,  $T_j = 25^\circ C$ , (unless otherwise specified).

Symbol	Parameter	Min.	Typ.	Max.	Units	Test Conditions
$T_{don}$	Turn-on delay time	—	10	40		
$T_{r1}$	Rise time to $V_{out} = V_{CC} - 5V$	—	25	60		
$T_{r2}$	Rise time $V_{CC} - 5V$ to $V_{out} = 90\%$ of $V_{CC}$	—	130	200		
$dV/dt$ (on)	Turn ON $dV/dt$	—	0.7	2	V/ $\mu s$	
$E_{on}$	Turn ON energy	—	1500	—	$\mu J$	
$T_{doff}$	Turn-off delay time	—	35	70		
$T_f$	Fall time to $V_{out} = 10\%$ of $V_{CC}$	—	25	50		
$dV/dt$ (off)	Turn OFF $dV/dt$	—	0.9	3	V/ $\mu s$	
$E_{off}$	Turn OFF energy	—	250	—	$\mu J$	
$T_{diag}$	$V_{out}$ to $V_{diag}$ propagation delay	—	5	15	$\mu s$	See figure 6

## Protection Characteristics

Symbol	Parameter	Min.	Typ.	Max.	Units	Test Conditions
$I_{lim}$	Internal current limit	7	10	14	A	$V_{out} = 0V$
$T_{sd+}$	Over-temp. positive going threshold	—	165	—		See fig. 2
$T_{sd-}$	Over-temp. negative going threshold	—	158	—		See fig. 2
$V_{sc}$	Short-circuit detection voltage (3)	2	3	4		See fig. 2
$V_{open load}$	Open load detection threshold	2	3	4		

(3) Referenced to  $V_{CC}$

## Lead Assignments

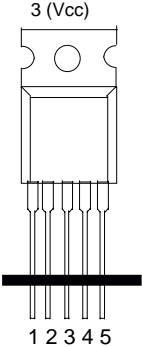
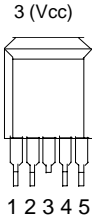
 <p>3 (Vcc)</p> <p>1 2 3 4 5</p>	<p>1 - Ground 2 - In 3 - Vcc 4 - DG 5 - Out</p>	 <p>3 (Vcc)</p> <p>1 2 3 4 5</p>
5 Lead - TO220		5 Lead - D <sup>2</sup> PAK (SMD220)
<b>IPS521</b>		<b>IPS521S</b>
<b>Part Number</b>		

**Functional Block Diagram**

All values are typical

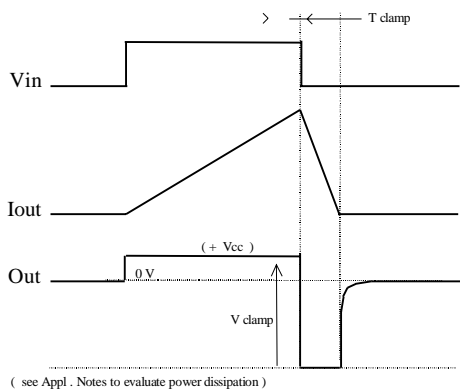
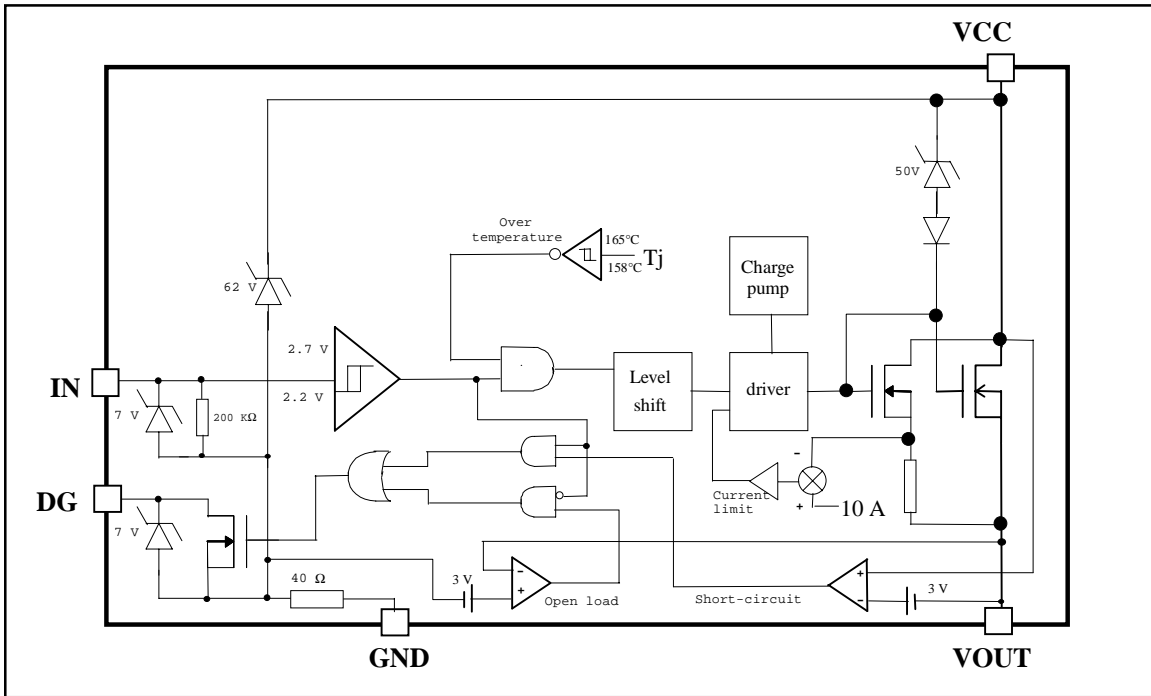

Figure 1 - Active clamp waveforms

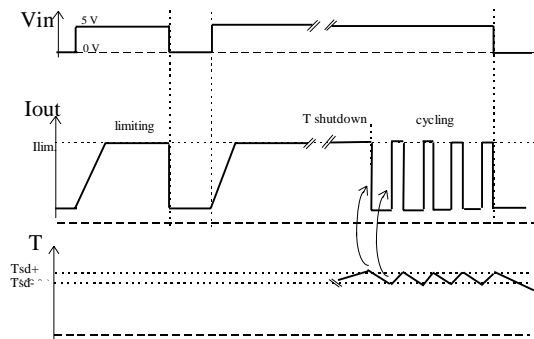

Figure 2 - Protection timing diagram

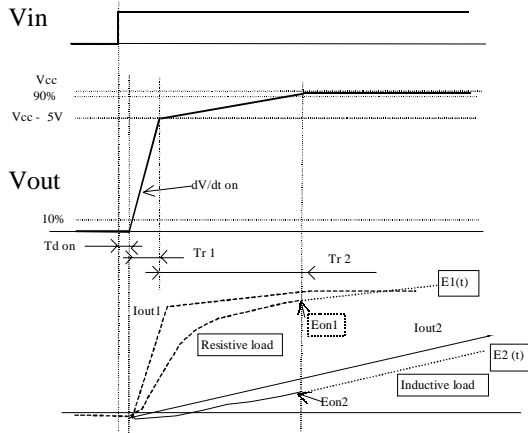

Figure 3 - Switching times definition (turn-on)  
Turn on energy with a resistive or an inductive load

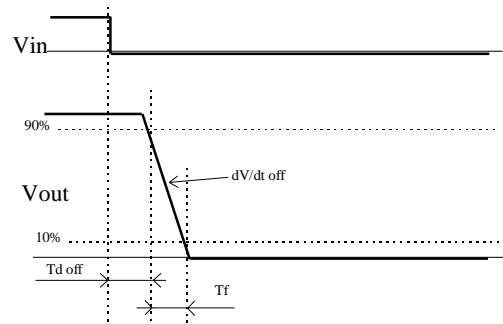

Figure 4 - Switching times definition (turn-off)

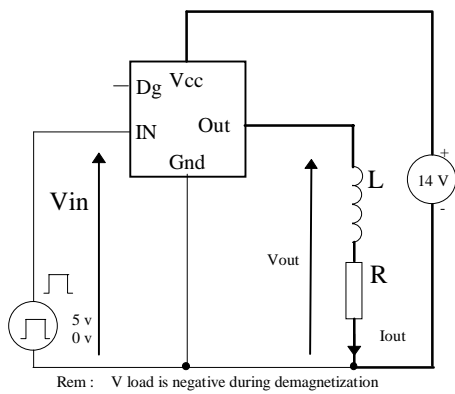

Figure 5 - Active clamp test circuit

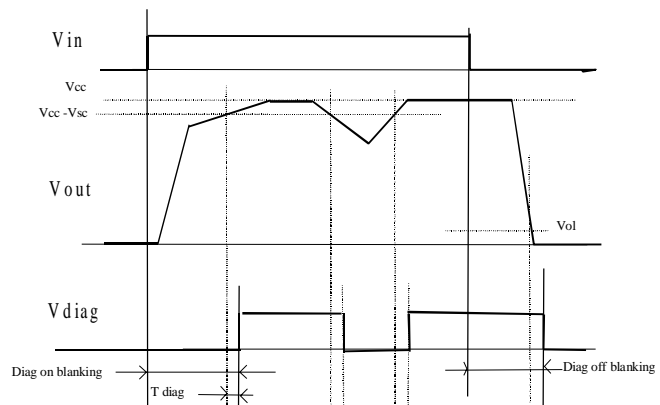

Figure 6 - Diagnostic delay definitions

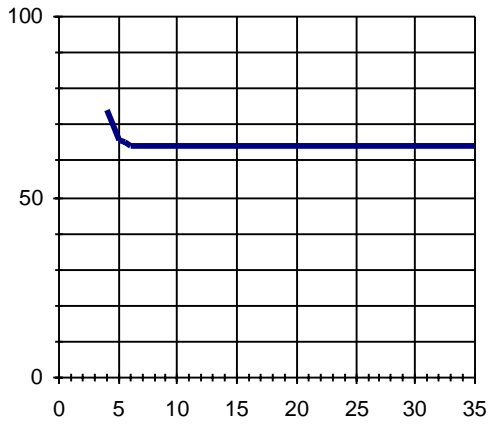

Figure 7 - R<sub>ds(on)</sub> (mΩ) Vs V<sub>CC</sub> (V)

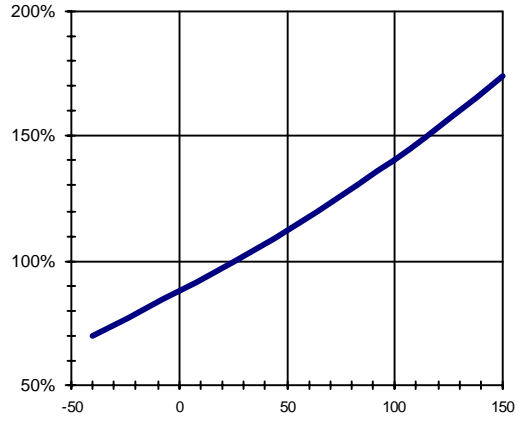

Figure 8 - Normalized R<sub>ds(on)</sub> (%) Vs T<sub>j</sub> (°C)

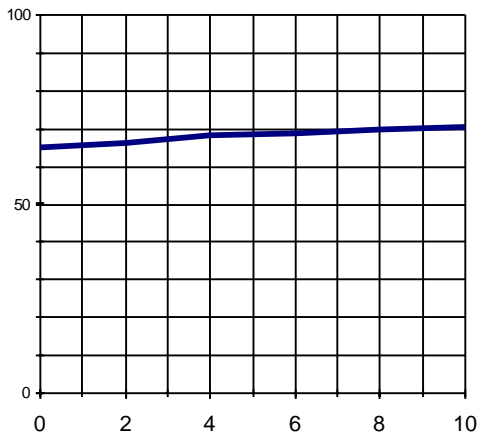

Figure 9 - R<sub>ds(on)</sub> (mΩ) Vs I<sub>out</sub> (A)

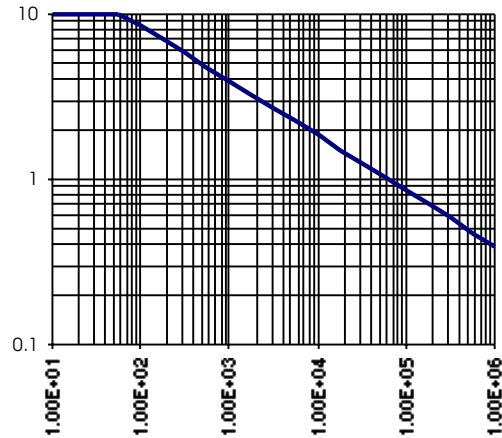

Figure 10 - Max. I<sub>out</sub> (A) Vs Load Inductance (uH)

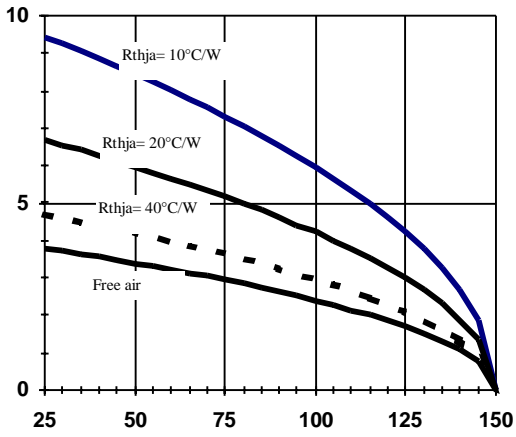

Figure 11a - Max load current (A) Vs Tamb (°C)  
IPS521

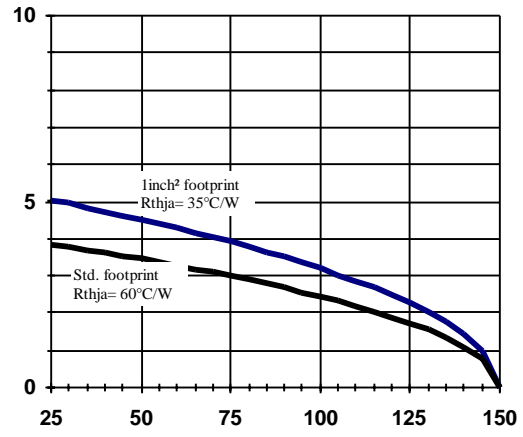

Figure 11b - Max load current (A) Vs Tamb (°C)  
IPS521S

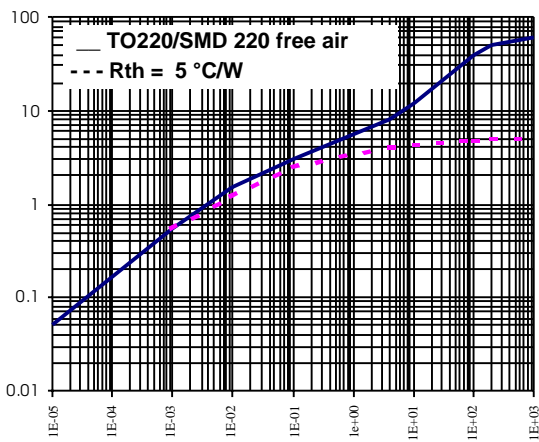

Figure 12 - Transient Thermal Impedance (°C/W)  
Vs Time (S)

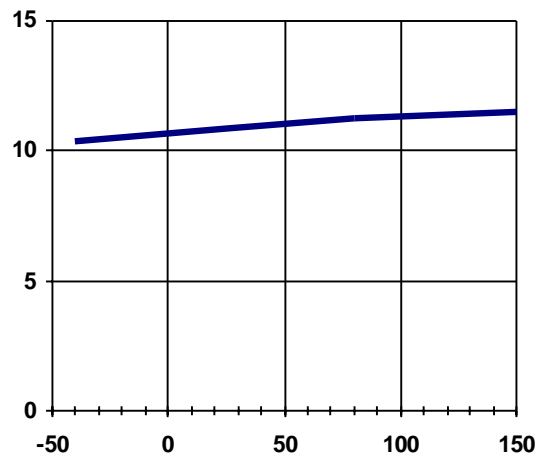

Figure 13 -  $I_{lim}$  (A) Vs  $T_j$  (°C)



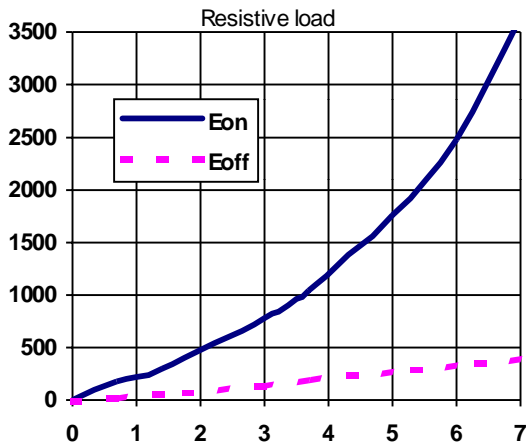

Figure 14 - E<sub>on</sub>, E<sub>off</sub> (μJ) Vs I<sub>out</sub> (A)

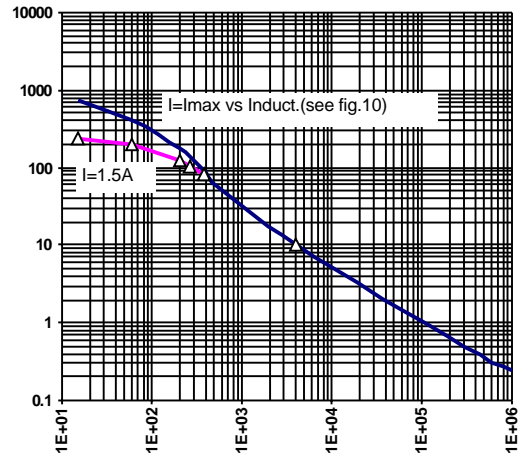

Figure 15 - E<sub>on</sub> (μJ) Vs Load Inductance (μH)  
(see Fig. 3)

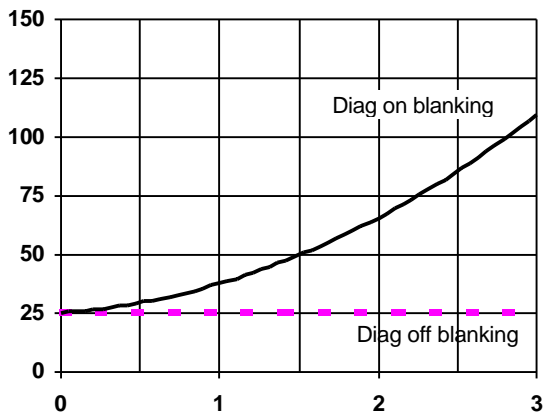

Figure 16 - Diag Blanking time (μs) Vs I<sub>out</sub> (A)  
(resistive load - see Fig. 6)

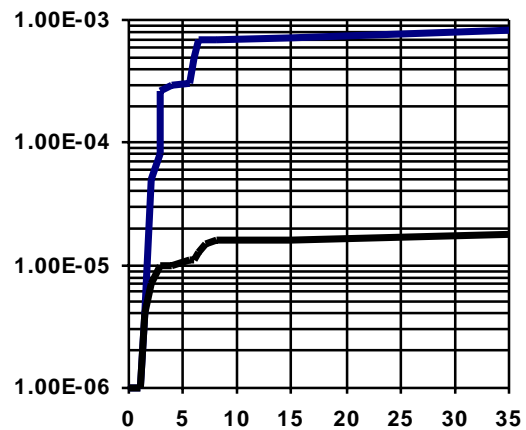
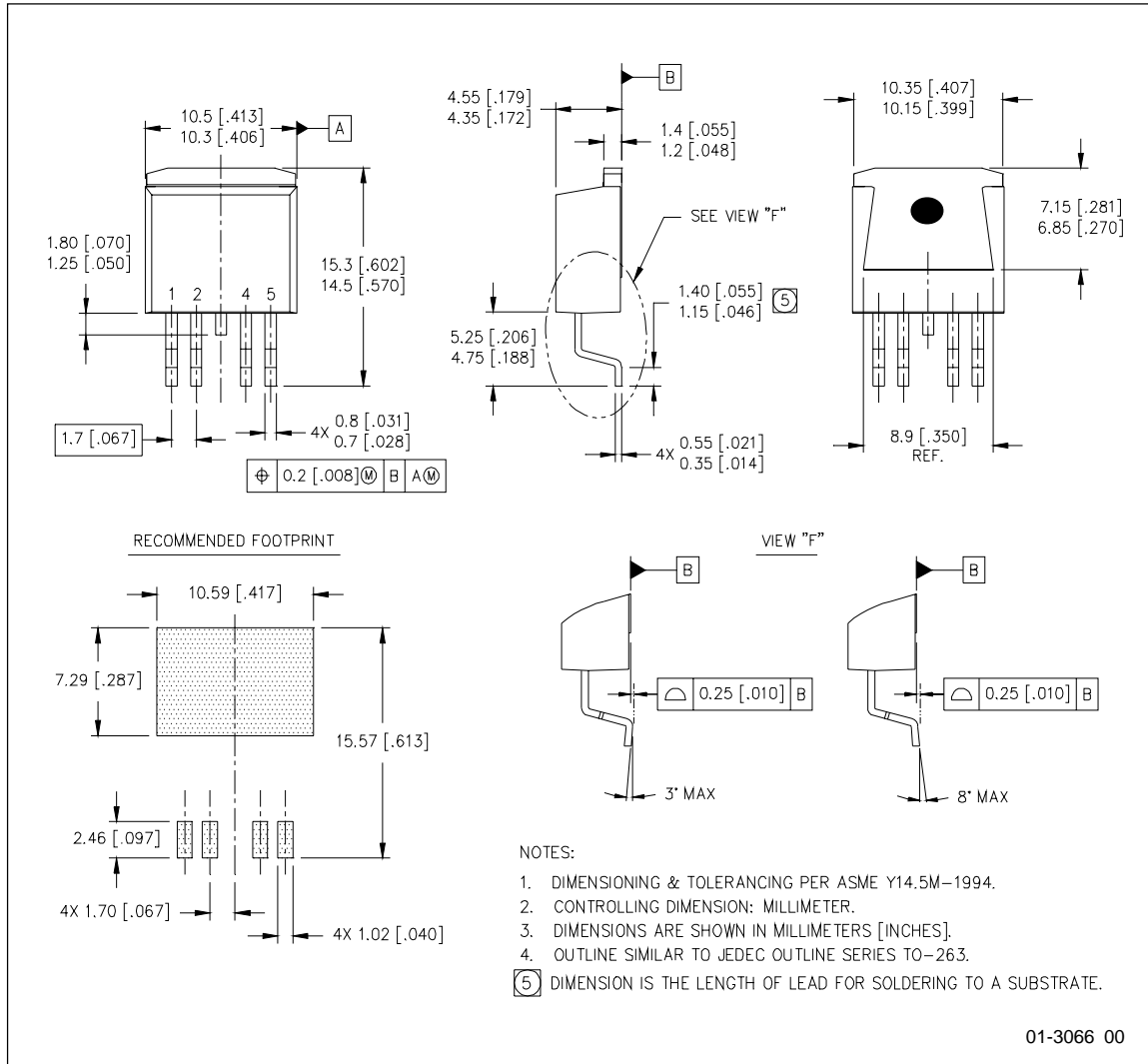

Figure 17 - I<sub>cc</sub> (mA) Vs V<sub>cc</sub> (V)



**Case Outline 5 Lead - D<sup>2</sup>PAK (SMD220)**



Note: For the most current drawings please refer to the IR website at:  
<http://www.irf.com/package/>