

RF Power Plate Capacitors with Contoured Rim, Class 1 Ceramic



FEATURES

- Small size
- High reliability
- Wide range of capacitance values

APPLICATIONS

- Induction and dielectric heating
- Antenna units
- Filter, bypass and coupling circuits

CAPACITANCE RANGE

5.6 pF to 2.0 nF

CAPACITANCE TOLERANCE

< 10 pF: ± 2 pF, ± 1 pF, ± 0.5 pF
 ≥ 10 pF: ± 20 %, ± 10 %, ± 5 %

CERAMIC DIELECTRIC

- R7 (TCC + 100 ppm/K)
- R16 (TCC + 100 ppm/K)
- R42 (TCC - 250 ppm/K)
- R85 (TCC - 750 ppm/K)
- N2200 (TCC - 2200 ppm/K)

RATED VOLTAGE

- 5.0 kV_p
- 7.5 kV_p

DIELECTRIC STRENGTH TEST

200 % of rated voltage, 50 Hz

DISSIPATION FACTOR

R7: max. 0.07 %

R16: max. 0.04 %

R42, R85: max. 0.05 %

N2200: max. 0.10 %

Measuring frequencies:

1 MHz (< 1 nF); 300 kHz or 100 kHz (≥ 1 nF)

INSULATION RESISTANCE

Min. 10 000 M Ω (at 25 °C)

OPERATING TEMPERATURE RANGE

-55 °C to +100 °C

QUICK REFERENCE DATA

DESCRIPTION	VALUE				
Ceramic Class	1				
Ceramic Dielectric	R7, R16, R42, R85, N2200				
Type	PS 20	PS 30	PS 40	PS 55	
Voltage (V _p)	5000	5000	7500	5000	5000
Min. Capacitance (pF)	5.6	10	120	22	22
Max. Capacitance (pF)	270	560	120	1000	2000
Mounting	Screw terminal				

MATERIAL

Capacitor elements made from class 1 ceramic dielectric with noble metal electrodes.

Connection terminals:
made from copper / brass, silver plated.

FINISH

Capacitor body completely protective lacquered.

MARKING

Type designator, capacitance value and tolerance, rated peak voltage, ceramic material code, production date code, manufacturer logo.

ACCESSORIES ADDED

Two screws and washers.



SAP PART NUMBER AND ELECTRICAL DATA						
PART NUMBER	CERAMIC	CAP. VALUES (pF)	RATED VOLTAGE (kV _p)	RATED POWER ⁽¹⁾ (kvar)	RATED CURRENT (A _{RMS})	
TYPE PS 20						
PS0020BE956##BF1	R7	5.6	5.0	5.0	5.0	
PS0020BE968##BF1		6.8				
PS0020BE982##BG1	R16	8.2		10		10
PS0020BE100##BG1		10				
PS0020BE120##BG1		12				
PS0020BE150##BG1		15				
PS0020BE180##BH1	R42	18		15		15
PS0020BE200##BH1		20				
PS0020BE220##BH1		22				
PS0020BE270##BH1		27				
PS0020BE330##BH1		33				
PS0020BE390##BJ1	R85	39		25		25
PS0020BE470##BJ1		47				
PS0020BE560##BJ1		56				
PS0020BE680##BJ1		68				
PS0020BE820##BJ1		82				
PS0020BE101##BJ1	N2200	100		10		10
PS0020BE121##AP1		120				
PS0020BE151##AP1		150				
PS0020BE181##AP1		180				
PS0020BE221##AP1		220				
PS0020BE271##AP1	270					
TYPE PS 30						
PS0030BE100##BF1	R7	10	5.0	8.0	10	
PS0030BE120##BF1		12				
PS0030BE150##BF1		15				
PS0030BE180##BF1		18				
PS0030BE200##BG1	R16	20		15		15
PS0030BE220##BG1		22				
PS0030BE270##BG1		27				
PS0030BE300##BG1		30				
PS0030BE330##BG1	R42	33		20		20
PS0030BE390##BG1		39				
PS0030BE470##BH1		47				
PS0030BE560##BH1		56				
PS0030BE680##BH1	R85	68	7.5	30		
PS0030BE820##BH1		82				
PS0030BE101##BJ1		100				
PS0030VZ121##BJ1		120				
PS0030BE151##BJ1	N2200	150	5.0	15		
PS0030BE181##BJ1		180				
PS0030BE201##BJ1		200				
PS0030BE221##BJ1		220				
PS0030BE271##AP1	N2200	270	15	15		
PS0030BE331##AP1		330				
PS0030BE391##AP1		390				
PS0030BE471##AP1		470				
PS0030BE561##AP1		560				

Notes

- # 14th to 15th digit: capacitance tolerance code < 10 pF: ± 2 pF = 15; ± 1 pF = 14; ± 0.5 pF = 13; ≥ 10 pF: ± 20 % = 38; ± 10 % = 36; ± 5 % = 33

(1) The surface temperature during operation must not exceed +100 °C



SAP PART NUMBER AND ELECTRICAL DATA					
PART NUMBER	CERAMIC	CAP. VALUES (pF)	RATED VOLTAGE (kV _p)	RATED POWER ⁽¹⁾ (kvar)	RATED CURRENT (A _{RMS})
TYPE PS 40					
PS0040BE220##BF1	R7	22	5.0	12	15
PS0040BE270##BF1		27			
PS0040BE300##BG1	R16	30		20	
PS0040BE330##BG1		33			
PS0040BE390##BG1		39			
PS0040BE470##BG1		47			
PS0040BE560##BG1		56			
PS0040BE680##BG1		68			
PS0040BE820##BH1	R42	82		25	
PS0040BE910##BH1		91			
PS0040BE101##BH1		100			
PS0040BE121##BH1		120			
PS0040BE151##BH1	R85	150		35	
PS0040BE181##BJ1		180			
PS0040BE201##BJ1		200			
PS0040BE221##BJ1		220			
PS0040BE241##BJ1		240			
PS0040BE251##BJ1		250			
PS0040BE271##BJ1		270			
PS0040BE331##BJ1		330			
PS0040BE361##BJ1	N2200	360	20		
PS0040BE391##BJ1		390			
PS0040BE471##AP1		470			
PS0040BE561##AP1		560			
PS0040BE681##AP1	N2200	680	20		
PS0040BE821##AP1		820			
PS0040BE102##AP1		1000			
PS0040BE102##AP1		1000			
TYPE PS 55					
PS0055BE220##BF1	R7	22	5.0	15	18
PS0055BE270##BF1		27			
PS0055BE330##BF1		33			
PS0055BE390##BF1		39			
PS0055BE470##BF1		47			
PS0055BE560##BG1	R16	56		40	
PS0055BE680##BG1		68			
PS0055BE820##BG1		82			
PS0055BE101##BG1		100			
PS0055BE121##BG1	R42	120		55	
PS0055BE151##BH1		150			
PS0055BE181##BH1		180			
PS0055BE221##BH1		220			
PS0055BE271##BH1	R85	270		55	
PS0055BE331##BJ1		330			
PS0055BE391##BJ1		390			
PS0055BE471##BJ1		470			
PS0055BE511##BJ1	N2200	510		25	
PS0055BE561##BJ1		560			
PS0055BE681##BJ1		680			
PS0055BE821##AP1		820			
PS0055BE102##AP1	N2200	1000	25		
PS0055BE122##AP1		1200			
PS0055BE152##AP1		1500			
PS0055BE182##AP1		1800			
PS0055BE202##AP1	N2200	2000			

Notes

- # 14th to 15th digit: capacitance tolerance code: ± 20 % = 38; ± 10 % = 36; ± 5 % = 33
- ⁽¹⁾ The surface temperature during operation must not exceed +100 °C



DIMENSIONS in millimeters (inches)

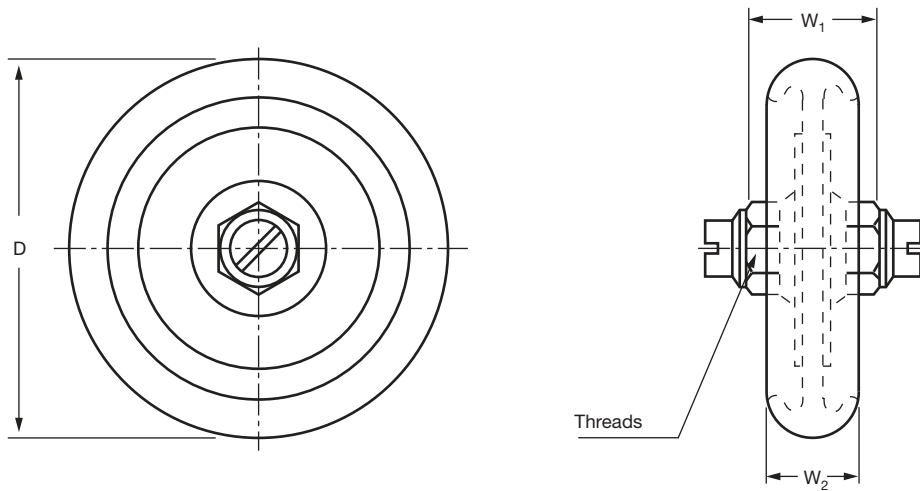

TYPE	PS 20	PS 30	PS 40	PS 55
Diameter D	24 ± 1 (0.95 ± 0.04)	34.5 ± 1.5 (1.36 ± 0.06)	44.5 ± 1.5 (1.75 ± 0.06)	56 ± 2 (2.20 ± 0.08)
Thread size	M5	M5	M6	M6
Width W ₁ max.	22 (0.87)	22 (0.87)	21 (0.82)	21 (0.82)
Width W ₂ max. ⁽¹⁾	16 (0.63)	16 (0.63)	15 (0.59)	15 (0.59)

Note

⁽¹⁾ Dimension W₂ will vary depending upon capacitance

RELATED DOCUMENTS

General Information	www.vishay.com/doc?22071
---------------------	--



Disclaimer

ALL PRODUCT, PRODUCT SPECIFICATIONS AND DATA ARE SUBJECT TO CHANGE WITHOUT NOTICE TO IMPROVE RELIABILITY, FUNCTION OR DESIGN OR OTHERWISE.

Vishay Intertechnology, Inc., its affiliates, agents, and employees, and all persons acting on its or their behalf (collectively, "Vishay"), disclaim any and all liability for any errors, inaccuracies or incompleteness contained in any datasheet or in any other disclosure relating to any product.

Vishay makes no warranty, representation or guarantee regarding the suitability of the products for any particular purpose or the continuing production of any product. To the maximum extent permitted by applicable law, Vishay disclaims (i) any and all liability arising out of the application or use of any product, (ii) any and all liability, including without limitation special, consequential or incidental damages, and (iii) any and all implied warranties, including warranties of fitness for particular purpose, non-infringement and merchantability.

Statements regarding the suitability of products for certain types of applications are based on Vishay's knowledge of typical requirements that are often placed on Vishay products in generic applications. Such statements are not binding statements about the suitability of products for a particular application. It is the customer's responsibility to validate that a particular product with the properties described in the product specification is suitable for use in a particular application. Parameters provided in datasheets and / or specifications may vary in different applications and performance may vary over time. All operating parameters, including typical parameters, must be validated for each customer application by the customer's technical experts. Product specifications do not expand or otherwise modify Vishay's terms and conditions of purchase, including but not limited to the warranty expressed therein.

Hyperlinks included in this datasheet may direct users to third-party websites. These links are provided as a convenience and for informational purposes only. Inclusion of these hyperlinks does not constitute an endorsement or an approval by Vishay of any of the products, services or opinions of the corporation, organization or individual associated with the third-party website. Vishay disclaims any and all liability and bears no responsibility for the accuracy, legality or content of the third-party website or for that of subsequent links.

Except as expressly indicated in writing, Vishay products are not designed for use in medical, life-saving, or life-sustaining applications or for any other application in which the failure of the Vishay product could result in personal injury or death. Customers using or selling Vishay products not expressly indicated for use in such applications do so at their own risk. Please contact authorized Vishay personnel to obtain written terms and conditions regarding products designed for such applications.

No license, express or implied, by estoppel or otherwise, to any intellectual property rights is granted by this document or by any conduct of Vishay. Product names and markings noted herein may be trademarks of their respective owners.