



MEMS flow sensors

MEMS flow sensors you can rely on

Precise, dependable mass flow measurement in a small package.

We have introduced a new generation of MEMS based flow sensors used for gas flow velocity and mass flow rate measurements. The 3D MEMS structure offers outstanding characteristics in terms of resolution and repeatability even at very low flow rates.

The D6F-V, D6F-W and D6F-P products incorporate a patent pending Dust Segregation System (DSS) allowing it to be used to monitor the performance of fans and air intakes and to detect clogged filters in general. Precision performance is maintained over the product life time with an integral DSS that separates up to 99.5% of dry air borne particulates (simulation result).

Gas/Air Flow

Flow measurement principle

Inside each D6F there is a highly sensitive MEMS flow chip that is only 1.55mm x 1.55mm x 0.4mm thick. The MEMS flow chip has two thermopiles either side of a tiny heater element used to measure the deviations in heat symmetry caused by the passing gas flow in either direction. A thin layer of insulating film protects the sensor chip from exposure to the gas.

When there is no flow present, temperature distribution concentrated around the heater is uniform and the differential voltage over the two thermopiles is 0V (Diagram 1).

When even the smallest flow is present, temperature on the side of the heater facing the flow cools, and warms up on the other side of the heater - heat symmetry collapses (Diagram 2).

The difference of temperature appears as a differential voltage between the 2 thermopiles - the flow velocity, direction and mass flow rate can be measured.

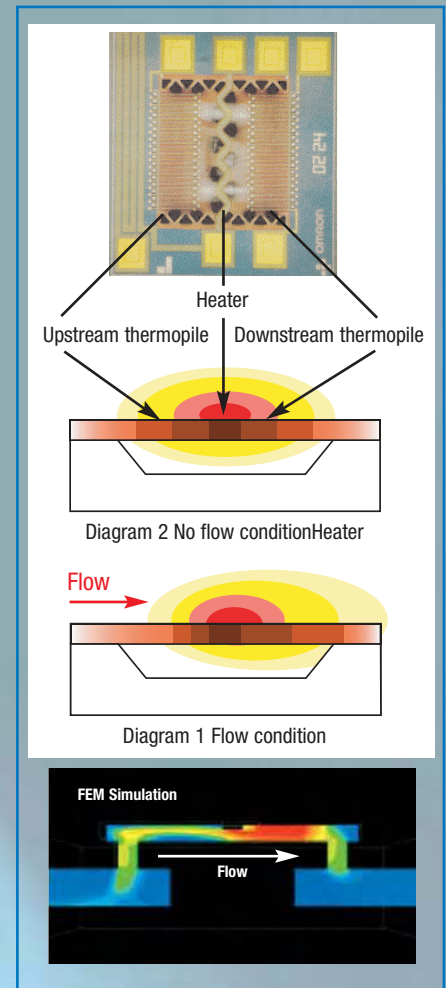

Omron has been a leading manufacturer of MEMS based components and modules for measurement and control applications since 1990 and has shipped more than 20 million products.

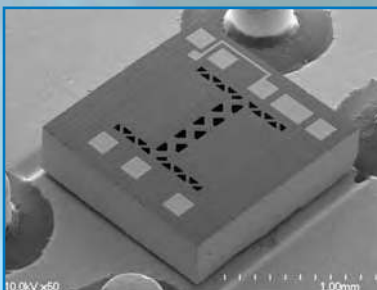

We concentrate on bulk micro-machining such as anodic bonding, electro chemical etch (ECE), silicon processes such as thin film deposition, wet and dry etching, electrode formation & fine plastic replication and glass wafer processes.

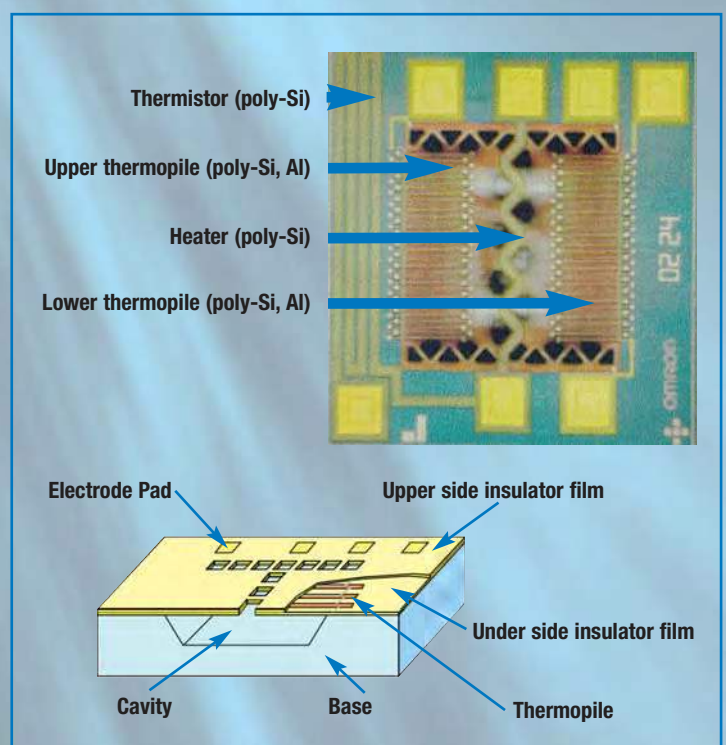

Gas and Air Flow Sensors

Our family of MEMS Flow Sensors includes intelligent compact models capable of measuring flow velocity and mass flow rate movement with highly repeatable accuracy at flow rates from 1LPM to 50LPM (Litre per minute). High sensitivity is achieved with the MEMS Flow Chip.

Supersensitive gas flow sensors based on proprietary MEMS technology are able to measure gas velocity, direction and mass flow rate for both extremely low and high flow rates. Capable of highly accurate measurements over a wider temperature range compared with conventional mass flow metering, the D6F can detect mass flows with a repeatability of up to $\pm 0.1\%$ and an accuracy of up to $\pm 3\%$ full scale deflection. The extreme sensitivity is achieved with a tiny heating element, associated with temperature sensors on both sides. Custom specific models could be made for quantities of approx. 100k pcs/year.



Intelli

Home Appliance

Gas Meter
Gas Leak Detector
Building Ventilation
Boiler/Combustion Control
Smoke Detector
Fan Assisted Heater

Medical

Chest Drainage
Ventilator
Anaesthetic device
CPAP
Oxygen Concentrator
Ozone Generator
Laparoscopic Surgery
Gas Chromatograph
Capnograph

Industrial

Process Control
Environmental Monitor/Gas Sniffer
Pressurised Cable Monitoring
Ventilator control
Clogged filter detection
Gas welding machine
Pick and Place
Fuel Cell
Scientific Devices
Gas flow controller
Fans



gent

Mass Flow Sensors

D6F-P

Uni-directional mass flow sensor*

Flow Range	1LPM , PCB terminal type (D6F-P0010A1) 1LPM , connector type (D6F-P0010A2)
Compact Size	27.2(L) x 17.2(W) x 35(H)mm
Supply Voltage	4.75 – 5.25VDC
Analogue Output	0.5 to 2.5V
Accuracy	+/- 5% F.S.
Temp Range	-10 to +60°C
Gas Type	Air

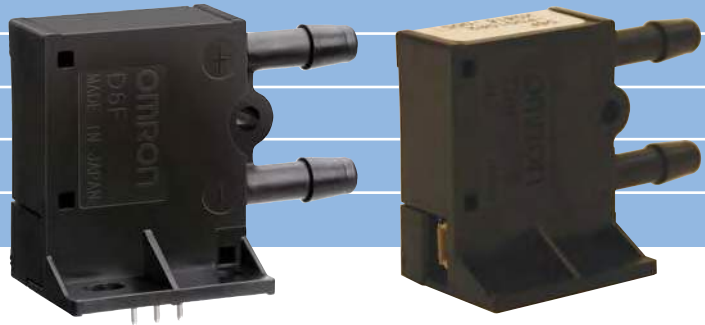

* Bi-directional mass flow sensor available on request.

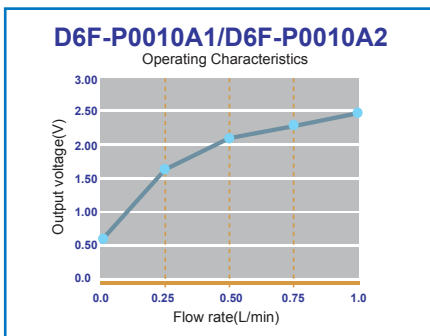

D6F-01A1 / 02A1

High accuracy mass flow sensor

Flow Range	1LPM (D6F-01A1-110) 2LPM (D6F-02A1-110)
Compact Size	66(L) x 36(W) x 15.1(H)mm
Supply Voltage	10.8 - 26.4VDC
Analogue Output	1 to 5V
Accuracy	+/- 3% F.S.
Temp Range	-10 to +60°C
Gas Type	Air

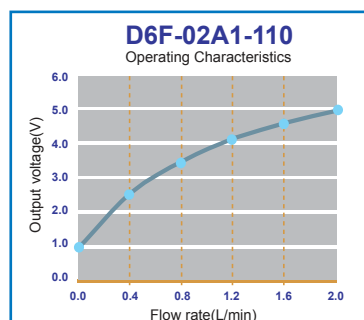
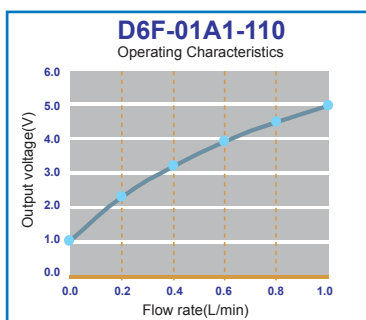

D6F-03A3

High accuracy mass flow sensor

Flow Range	3LPM (D6F-03A3-000)
Ultra-Compact Size	36.6(L) x 8(W) x 16.8(H)mm
Supply Voltage	10.8 - 26.4VDC
Analogue Output	1 to 5V
Accuracy	+/-5% F.S.
Temp Range	0 to 50°C
Gas Type	Air

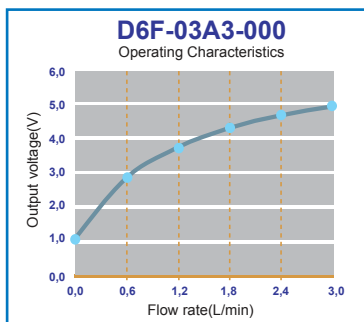

D6F-01N2 / 02L2 / 05N2

High accuracy mass flow sensor

Flow Range	1LPM (D6F-01N2-000), 2LPM (D6F-02L2-000), 5LPM (D6F-05N2-000)
Compact Size	62 (L) x 21.6(W) x 22.1 (H)mm
Supply Voltage	10.8 - 26.4VDC
Analogue Output	1 to 5V
Accuracy	+/- 3% F.S.
Temp Range	-10 to +60°C
Gas Type	N2 type LNG (Liquified Natural Gas) L2 type LPG (Liquified Propane Gas)

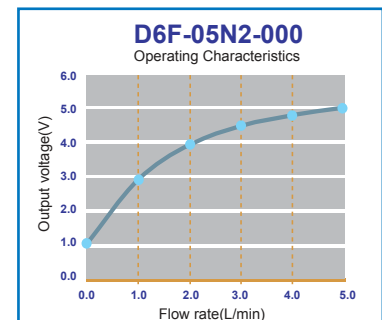
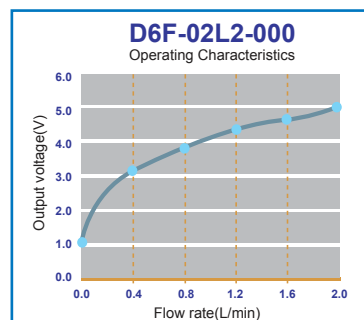
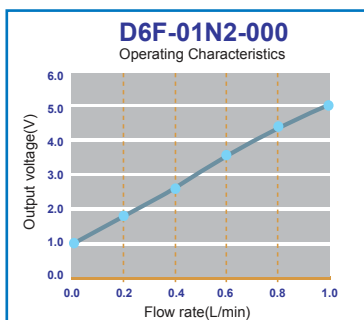

Mass Flow Sensors

D6F-10A5 / 20A5 / 50A5-10A6 / 20A6 / 50A6

High accuracy mass flow sensor

Flow Range	10LPM (D6F-10A5/10A6-000), 20LPM (D6F-20A5/20A6-000) 50LPM (D6F-50A5/A6-000)
Compact Size	78(L) x 30(W) x 30 (H)mm
Supply Voltage	10.8 - 26.4VDC
Analogue Output	1 to 5V
Accuracy	+/- 3% F.S.
Temp Range	-10 to +60°C
Gas Type	Air

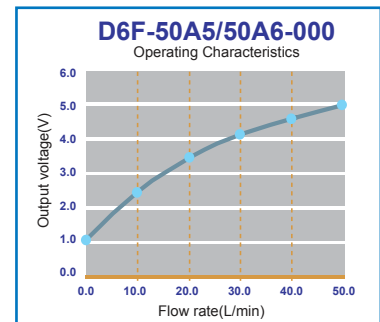
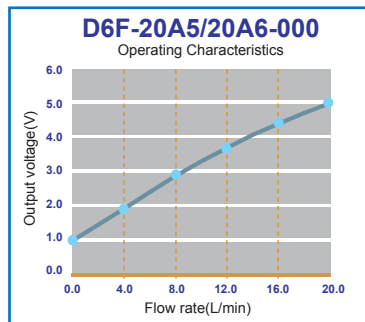
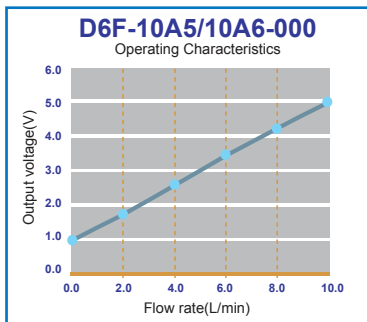
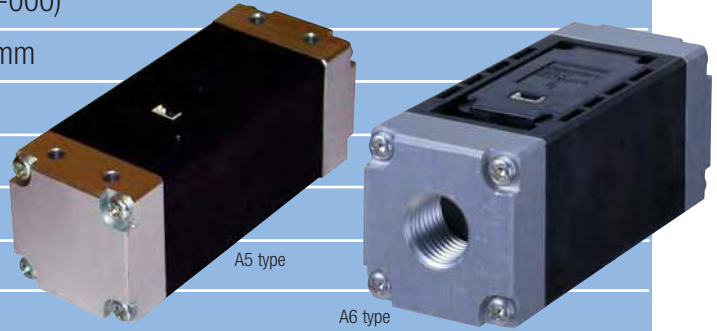

Air Velocity Sensors

Our D6F-W and D6F-V Sensors incorporate a Dust Segregation System (DSS) that helps maintain sensing performance in a variety of applications.

The housing design is based on a centrifugal principle to segregate particulates from the air. Most particulates cannot pass through the sensing area and are discharged through the exhaust route. As a result of the numerical analysis, the efficiency of the Dust Segregation System separates up to 99.5% of dry particulates. The D6F-W01A1 and D6F-W04A1 airflow sensors can measure air velocity from 0-1m/s and 0-4m/s with an accuracy of +/-5% full scale deflection. The D6F-V03A1 measures 0-3m/s. Each is supplied as standard, optimally adjusted at the factory so easy and rapid user application is guaranteed.

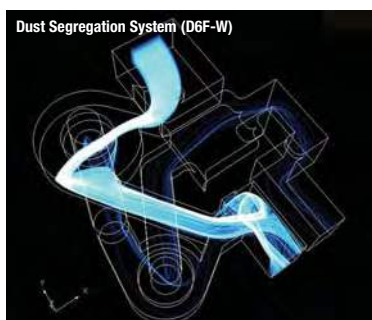

Perf



Cassette (ceiling/suspended) Multimodular Air Conditions
Duct Connected Heating and Air Conditioning Systems
Alternative for Single Point Pitot tube
Air & Water Air Conditioning Systems
Air Purifiers/ Dehumidifiers
Fan Assisted Heaters
Air Cooled, High Power Indoor Lighting
Mission Critical PC, Workstation Ventilation
19" Rack Ventilation Systems
LCD Projectors
AV Electronics Equipment

ormance

Air Velocity Sensors

D6F-W01A1 / W04A1

Precision air flow detection sensor

Flow Range	1m/s (D6F-W01A1) 4m/s (D6F-W04A1)
Ultra Compact Size	20(L) x 39(W) x 9(H)mm
Supply Voltage	10.8 - 26.4VDC
Analogue Output	1 to 5V
Accuracy	+/- 5% F.S.
Temp Range	-10 to +60°C
Gas Type	Air

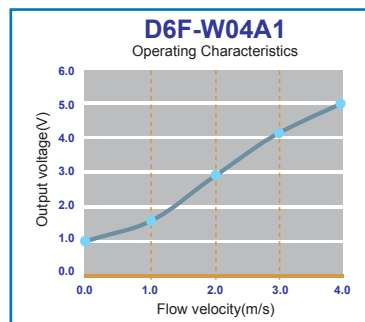
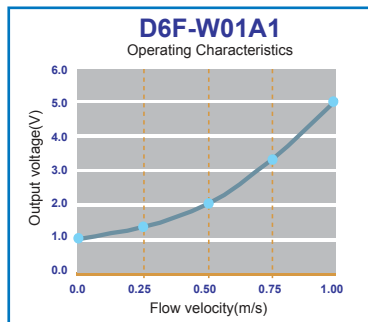

D6F-V03A1

Precision air flow detection sensor

Flow Range	3m/s (D6F-V03A1)
Ultra Compact Size	24(L) x 14(W) x 8(H)mm
Supply Voltage	3.15 - 3.45VDC
Analogue Output	0.5 to 2V
Accuracy	+/- 10% F.S.
Temp Range	-10 to +60°C
Gas Type	Air

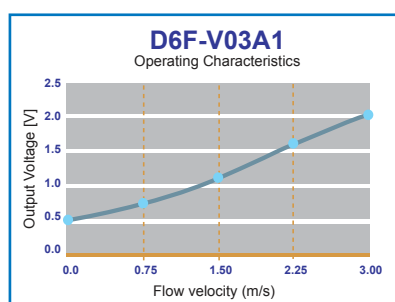

Clogged Filter Detection (Configuration 1)

The sensor detects the pressure drop over the filter. The moment this drop exceeds a given threshold, a warning signal

indicating the need for filter replacement is sent out.

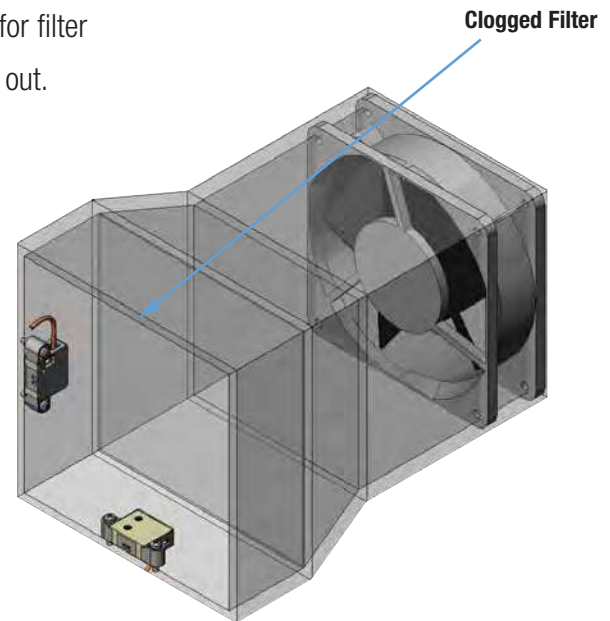
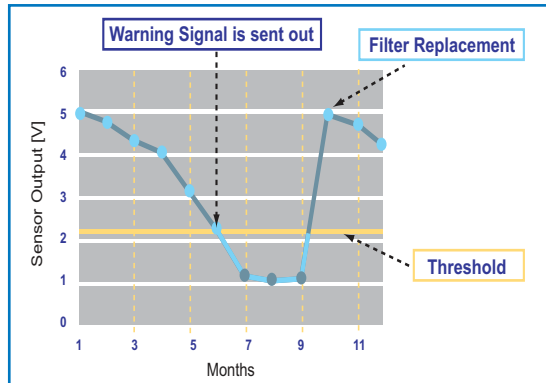

Clogged Filter Detection (Configuration 2)

Filter clogging can be detected, also using the bypass-like configuration. The differential pressure between upstream and downstream of the filter grows in proportion to the

accumulation of dirt in the filter, and the output voltage of the sensor located on the bypass channel increases.

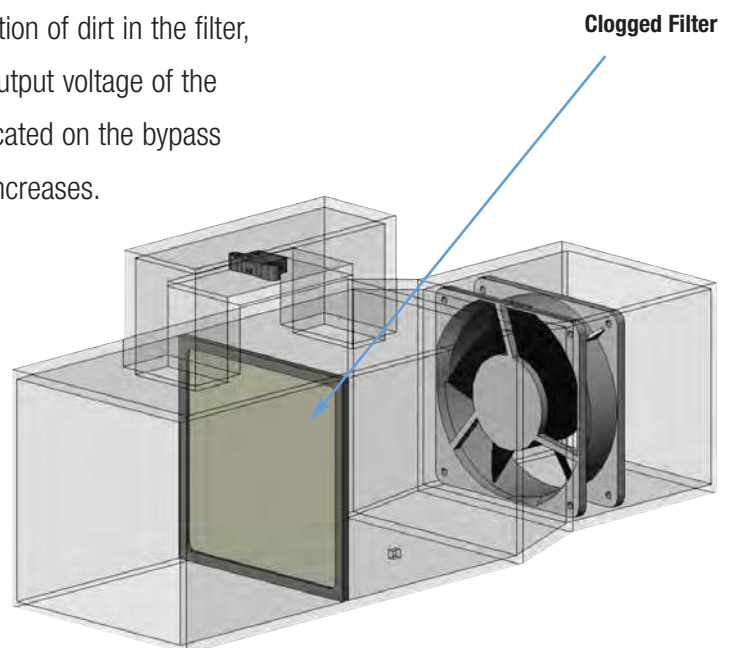
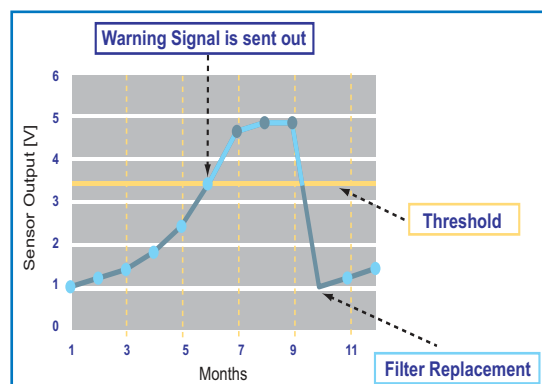



**Omron Electronic Components
Europe B.V.**

Sales Division France
14, rue de Lisbonne
93561 Rosny Sous Bois
France
Tel: +33 1 56 63 19 00
Fax: +33 1 48 55 97 75

**Omron Electronic Components
Europe B.V.**

Sales Division Central Europe
Gruber Strasse 60d
85586 Poing
Germany
Tel: +49 8121 77240
Fax: +49 8121 772440

**Omron Electronic Components
Europe B.V.**

Sales Division Italy
Viale Certosa 49
20149 Milano
Italy
Tel: +39 02 3268 850
Fax: +39 02 3268 851

**Omron Electronic Components
Europe B.V.**

Sales Division Benelux
Wegalaan 57
2132 JD Hoofddorp
The Netherlands
Tel: +31 23 568 1200
Fax: +31 23 568 1212

**Omron Electronic Components
Europe B.V.**

Sales Division Iberia
Arturo Soria 95
28027 Madrid
Spain
Tel: +34 91 377 7900
Fax: +34 91 377 7987

**Omron Electronic Components
Europe B.V.**

Sales Division Nordic
Box 1275, Norgegatan 1
S-164 32 Kista
Sweden
Tel: +46 8 632 35 20
Fax: +46 8 632 35 35

**Omron Electronic Components
Europe B.V.**

Sales Division UK & Ireland
1 Bishop Square,
Hatfield Business Park
Hatfield,
Hertfordshire AL10 9NE
United Kingdom
Tel: +44 870 750 5661
Fax: +44 870 750 5662

**Omron Electronic Components
Europe B.V.**

Emerging Markets Operations
CBC 1- ~
Karadzicova 8
821 08 Bratislava
Slovakia
Tel: +421 2582 40950
Fax: +421 2582 40999

Head Office

Omron Electronic Components Europe B.V.

Wegalaan 57
2132 JD Hoofddorp
The Netherlands
Tel: +31 23 568 1200
Fax: +31 23 568 1222
Email: info-components@eu.omron.com