

- 1 HOUSING: POLYESTER, UL 94V-0 RATED, BLACK.
- 2 SHELL: CARBON STEEL.
- 3 SHELL: 5.08um [.000200] MIN TIN OVER 2.54um [.000100] MIN COPPER.
- 4 GOLD FLASH FOR A LENGTH OF 2.54[.100] MIN FROM MATING END, 2.54um [.000100] MIN TIN OR TIN-LEAD ON OPPOSITE END, BOTH OVER 1.27um [.000050] MIN NICKEL.
- 5 0.76um [.000030] MIN GOLD FOR A LENGTH OF 2.54 [.100] MIN FROM MATING END, 2.54um [.000100] MIN TIN OR TIN-LEAD ON OPPOSITE END, BOTH OVER 1.27um [.000050] MIN NICKEL.
- 6 NOTE DELETED.
- 7 DATUMS AND BASIC DIMENSIONS ESTABLISHED BY CUSTOMER.
- 8 2.79[.110] MAX IN SHELL TAB CLINCH AREAS.
- 9 SUPERSEDED BY 747150-2.
- 10 SUPERSEDED BY 747150-9.
- 11 SUPERSEDED BY 1-747150-6.
- 12 OBSOLETE.
- 13 CONTACTS: PHOSPHOR BRONZE.
- 14 SCREWLOCKS: ZINC.
- 15 INSERTS: BRASS.

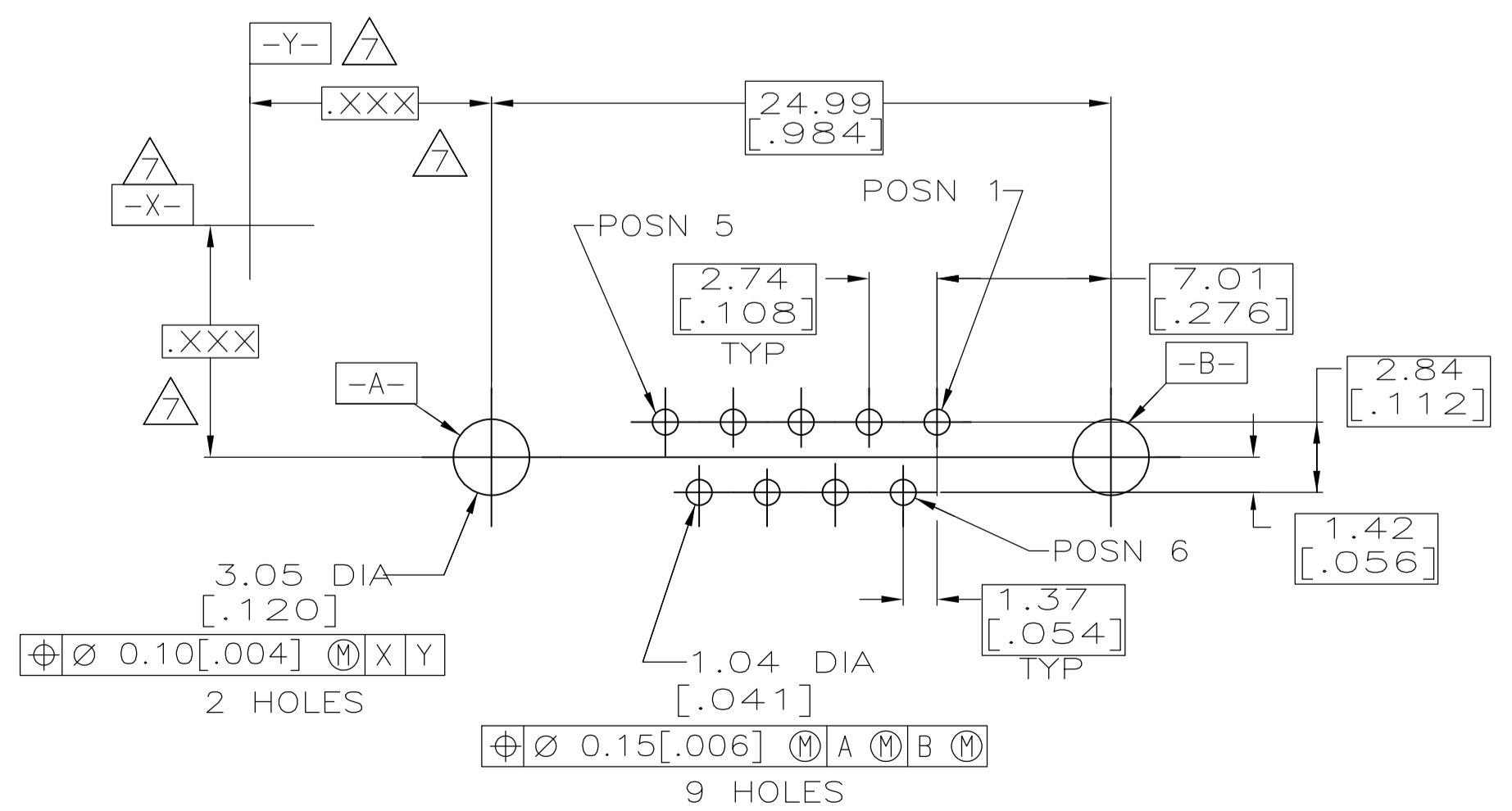
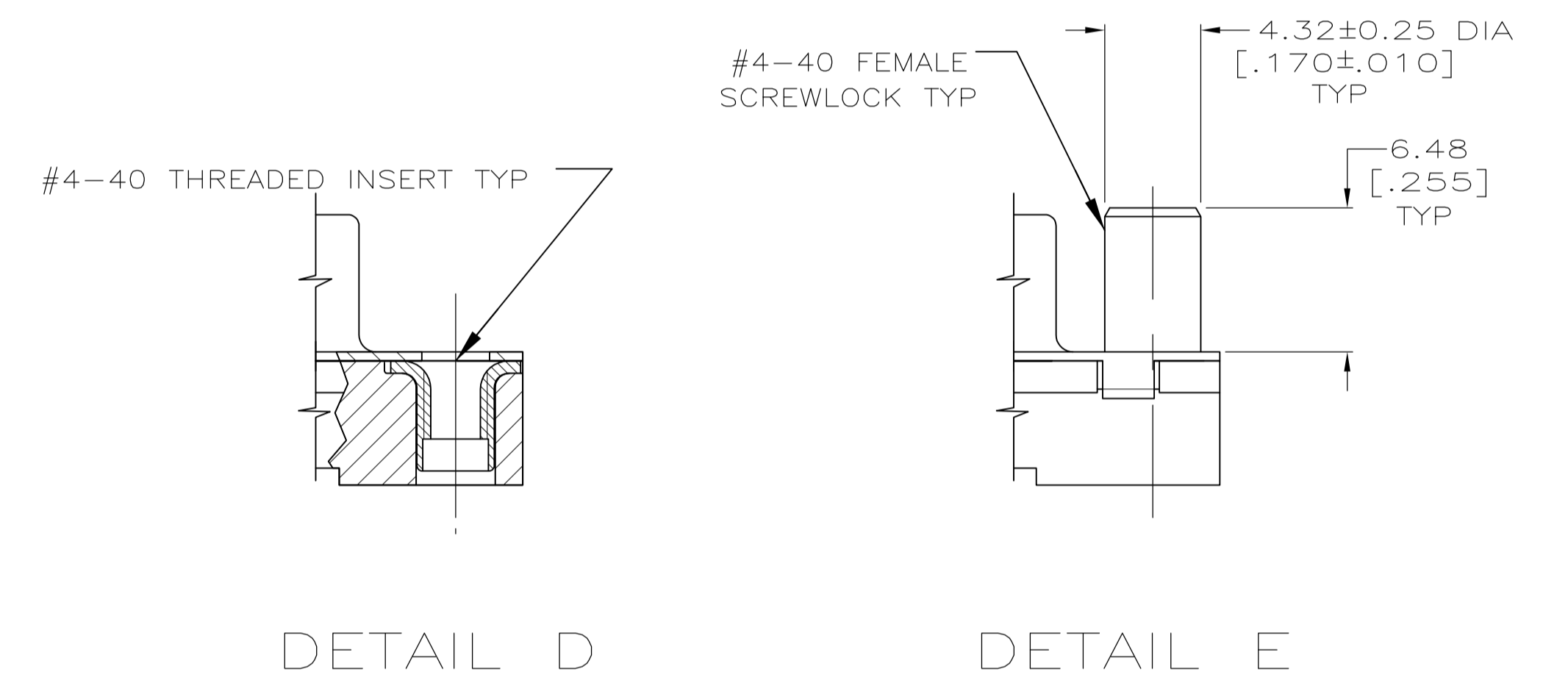
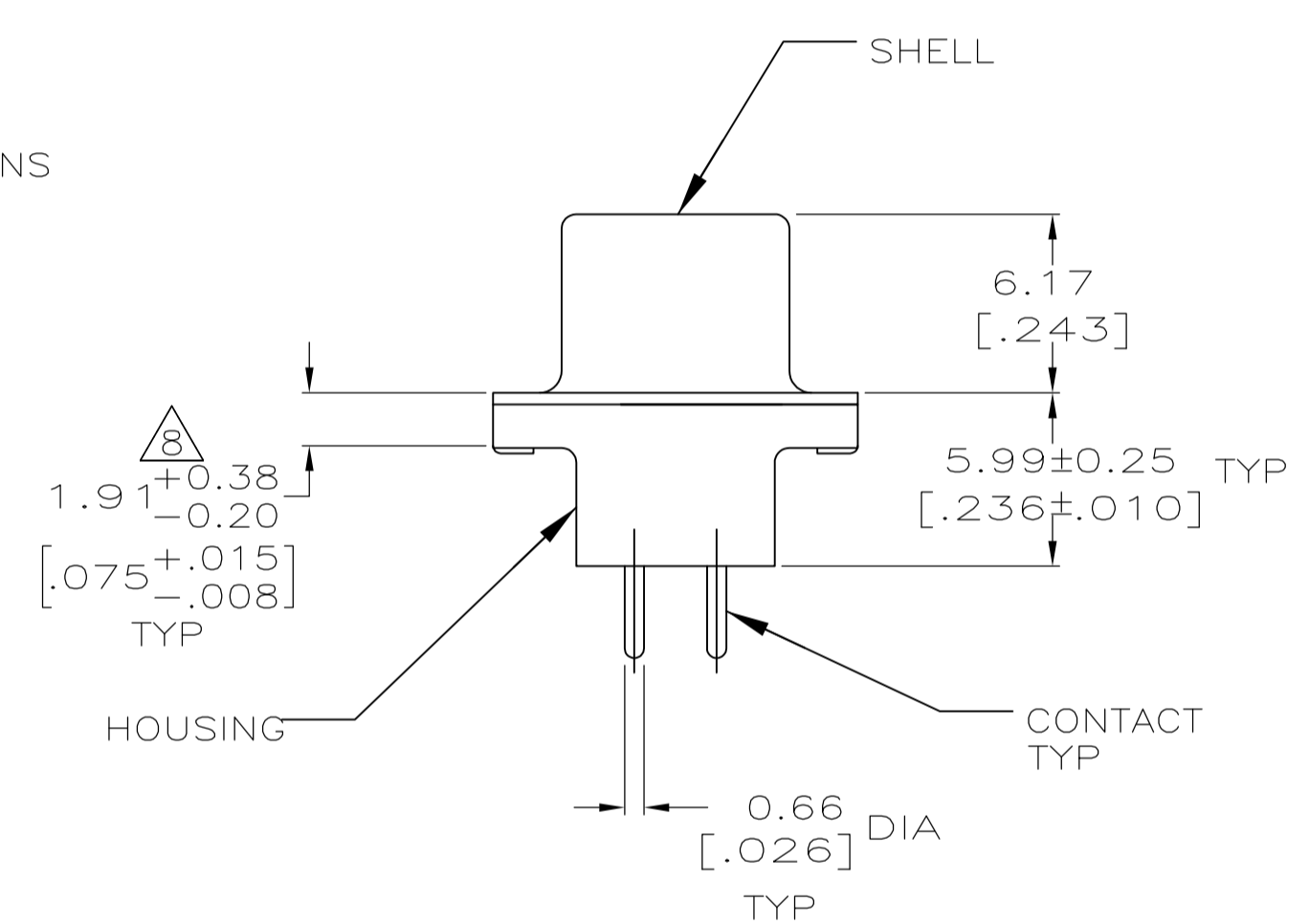
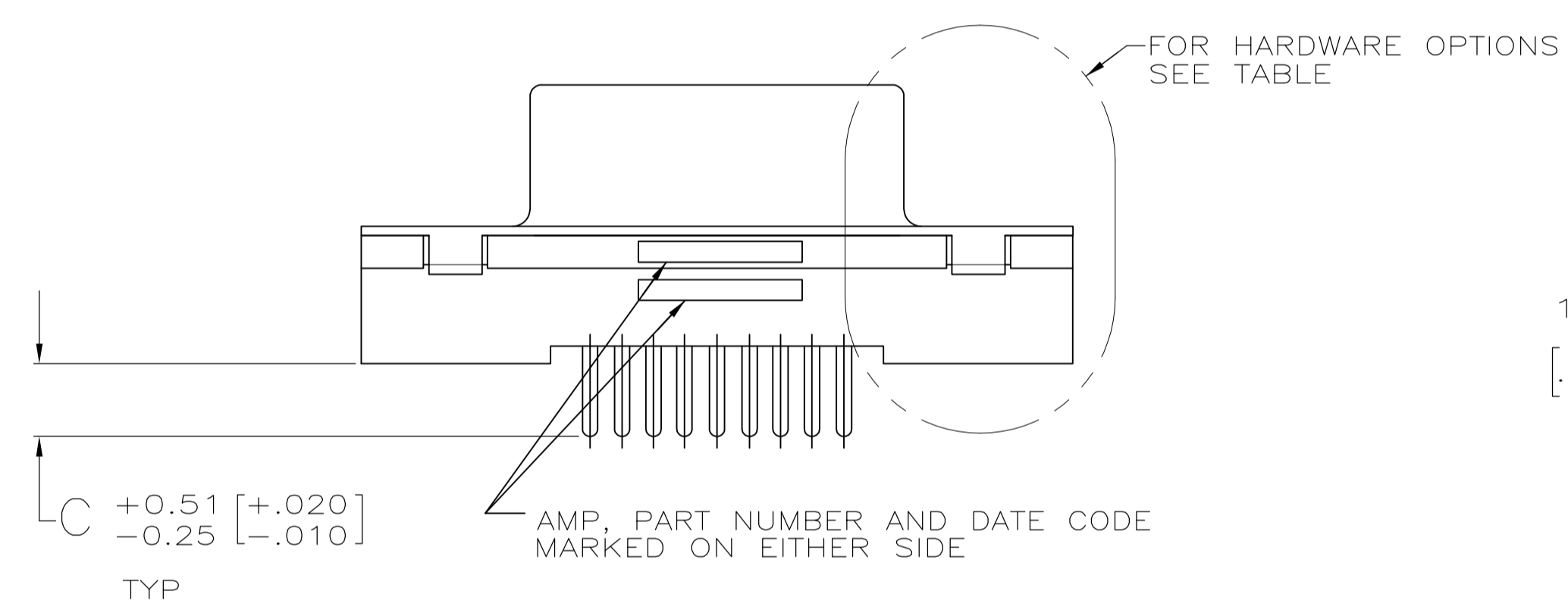
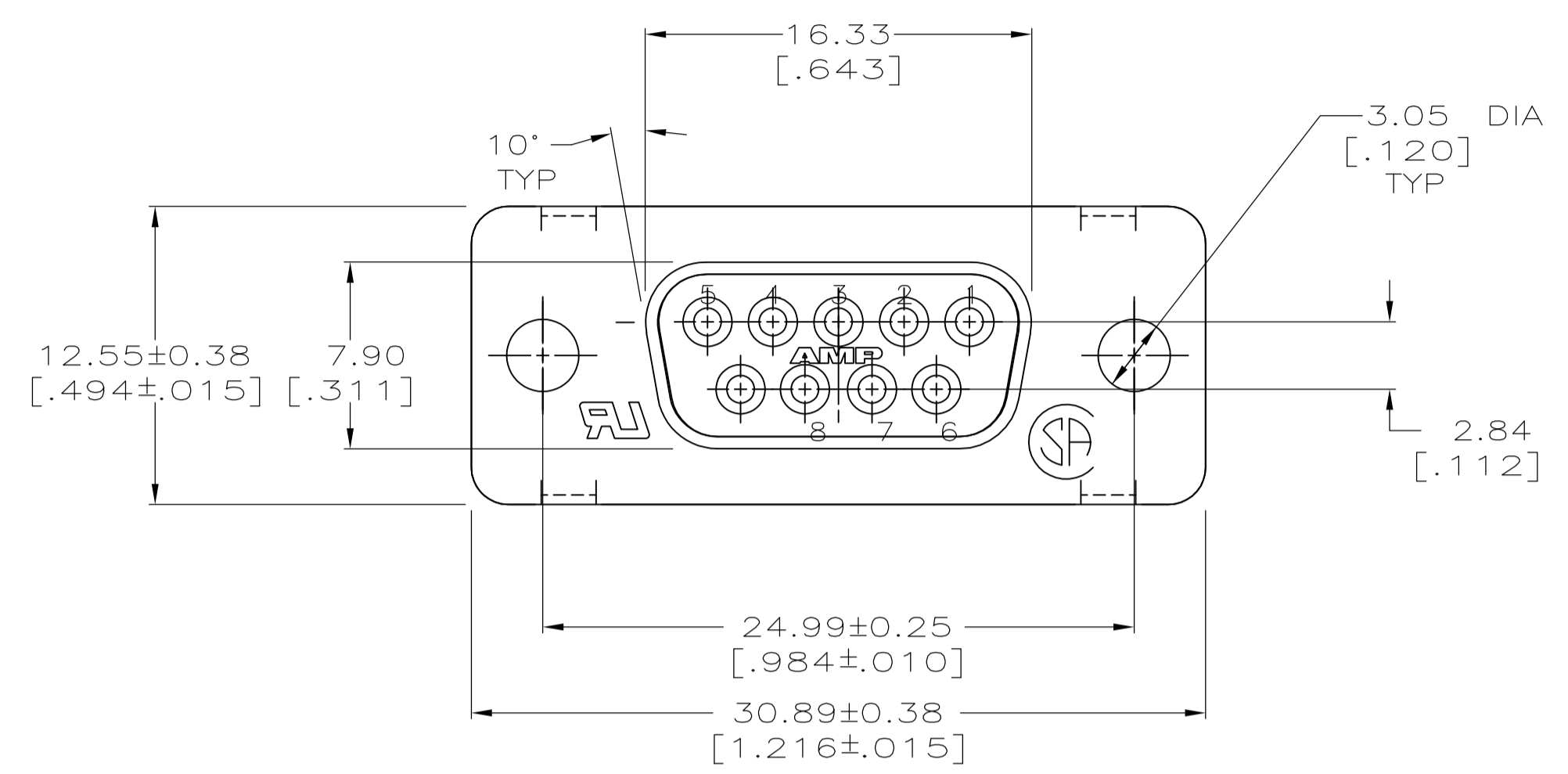

RECOMMENDED PC BOARD LAYOUT
CONNECTOR SIDE OF PC BOARD

W/FEMALE SCREWLOCKS PER DETAIL E	5	4.32 [.170]	1-747150-6
	4	4.32 [.170]	1-747150-5
W/THREADED INSERTS PER DETAIL D	5	3.18 [.125]	1-747150-4
	4	3.18 [.125]	1-747150-3
	5	6.35 [.250]	1-747150-1
	4	4.32 [.170]	747150-9
WO/FEMALE SCREWLOCKS OR THREADED INSERTS AS SHOWN	5	3.18 [.125]	747150-8
	4	3.18 [.125]	747150-7
	5	4.32 [.170]	747150-4
HARDWARE OPTIONS	5	3.18 [.125]	747150-2
	4	3.18 [.125]	747150-1
CONTACTS	C		PART NO
FINISH	C		

THIS DRAWING IS A CONTROLLED DOCUMENT.

DIMENSIONS: mm [INCHES]	TOLERANCES UNLESS OTHERWISE SPECIFIED:	DIN 3-22-93	BROCKWAY 5-10-93	DRW: R STONE	CHK: R STONE	APVD: -	NAME: -	PRODUCT SPEC: 108-40025	APPLICATION SPEC: 114-40023	SIZE: A1	SCALE: 4:1	SHEET: 1 of 1	REV: M1	
0 PLC ± -	1 PLC ± -	2 PLC ± 0.13 [.005]	3 PLC ± -	4 PLC ± -	ANGLES ± -	FINISH: 3	CONTACTS: SEE TABLE	RECEPTACLE ASSEMBLY, SIZE 1, 9 POSITION FRONT METAL SHELL, WITH OR WITHOUT SCREWLOCKS OR INSERTS.	TE Connectivity	RESTRICTED TO: -	CUSTOMER DRAWING	SCALE: 4:1	SHEET: 1 of 1	REV: M1