

4-Mbit (256 K × 16) Static RAM

Features

- Pin-and function-compatible with CY7C1041B
- High speed
 - $t_{AA} = 10 \text{ ns}$
- Low active power
 - $I_{CC} = 90 \text{ mA}$ at 10 ns (Industrial)
- Low CMOS standby power
 - $I_{SB2} = 10 \text{ mA}$
- 2.0 V data retention
- Automatic power-down when deselected
- TTL-compatible inputs and outputs
- Easy memory expansion with \overline{CE} and \overline{OE} features
- Available in Pb-free 44-pin (400-Mil) Molded SOJ and 44-pin TSOP II packages

Functional Description

The CY7C1041D ^[1] is a high-performance CMOS static RAM organized as 256K words by 16 bits. Writing to the device is accomplished by taking Chip Enable (\overline{CE}) and Write Enable (\overline{WE}) inputs LOW. If Byte Low Enable (\overline{BLE}) is LOW, then data from I/O pins (I/O_0 through I/O_7), is written into the location

specified on the address pins (A_0 through A_{17}). If Byte High Enable (\overline{BHE}) is LOW, then data from I/O pins (I/O_8 through I/O_{15}) is written into the location specified on the address pins (A_0 through A_{17}).

Reading from the device is accomplished by taking Chip Enable (\overline{CE}) and Output Enable (\overline{OE}) LOW while forcing the Write Enable (\overline{WE}) HIGH. If Byte Low Enable (\overline{BLE}) is LOW, then data from the memory location specified by the address pins will appear on I/O_0 to I/O_7 . If Byte High Enable (\overline{BHE}) is LOW, then data from memory will appear on I/O_8 to I/O_{15} . See the truth table at the back of this data sheet for a complete description of read and write modes.

The input/output pins (I/O_0 through I/O_{15}) are placed in a high-impedance state when the device is deselected (\overline{CE} HIGH), the outputs are disabled (\overline{OE} HIGH), the \overline{BHE} and \overline{BLE} are disabled (\overline{BHE} , \overline{BLE} HIGH), or during a write operation (\overline{CE} LOW, and \overline{WE} LOW).

The CY7C1041D is available in a standard 44-pin 400-mil-wide body width SOJ and 44-pin TSOP II package with center power and ground (revolutionary) pinout.

The CY7C1041D is suitable for interfacing with processors that have TTL I/P levels. It is not suitable for processors that require CMOS I/P levels. Please see [Electrical Characteristics on page 4](#) for more details and suggested alternatives.

For a complete list of related documentation, [click here](#).

Logic Block Diagram

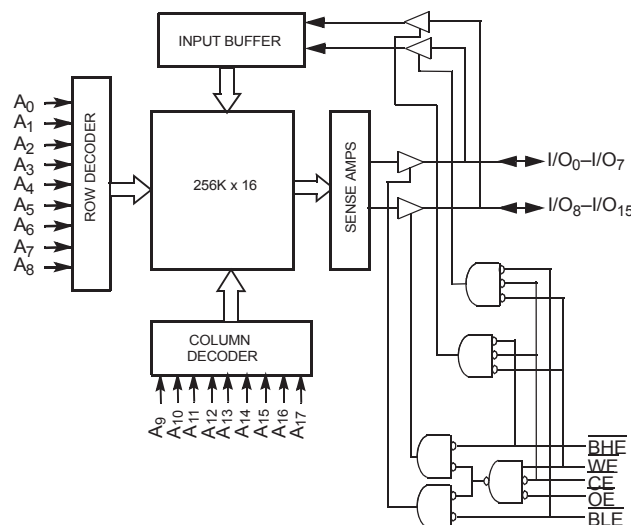

Note

1. For guidelines on SRAM system design, please refer to the "System Design Guidelines" Cypress application note, available on the internet at www.cypress.com.

Contents

Pin Configuration	3	Ordering Information	11
Selection Guide	3	Ordering Code Definitions	11
Maximum Ratings	4	Package Diagrams	12
Operating Range	4	Acronyms	13
Electrical Characteristics	4	Document Conventions	13
Capacitance	5	Units of Measure	13
Thermal Resistance	5	Document History Page	14
AC Test Loads and Waveforms	5	Sales, Solutions, and Legal Information	16
Data Retention Characteristics	6	Worldwide Sales and Design Support	16
Data Retention Waveform	6	Products	16
Switching Characteristics	7	PSoC® Solutions	16
Switching Waveforms	8	Cypress Developer Community	16
Truth Table	11	Technical Support	16

Pin Configuration

Figure 1. 44-pin SOJ / TSOP II pinout (Top View)

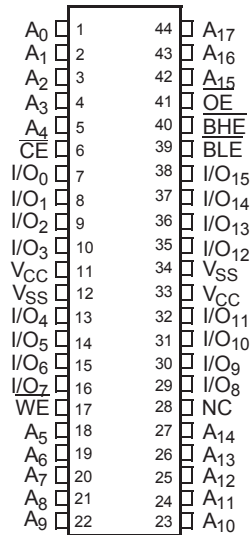

Selection Guide

Description	-10 (Industrial)	-12 (Automotive) ^[2]	Unit
Maximum Access Time	10	12	ns
Maximum Operating Current	90	95	mA
Maximum CMOS Standby Current	10	15	mA

Note

2. Automotive product information is Preliminary.

Maximum Ratings

Exceeding maximum ratings may shorten the useful life of the device. User guidelines are not tested.

Storage Temperature	-65 °C to +150 °C
Ambient Temperature with Power Applied	-55 °C to +125 °C
Supply Voltage on V _{CC} to Relative GND [3]	-0.5 V to +6.0 V
DC Voltage Applied to Outputs in High Z State [3]	-0.5 V to V _{CC} + 0.5 V
DC Input Voltage [3]	-0.5 V to V _{CC} + 0.5 V

Current into Outputs (LOW)	20 mA
Static Discharge Voltage (per MIL-STD-883, Method 3015)	>2001 V
Latch-up Current	>200 mA

Operating Range

Range	Ambient Temperature	V _{CC}	Speed
Industrial	-40 °C to +85 °C	5 V ± 0.5	10 ns
Automotive	-40 °C to +125 °C	5 V ± 0.5	12 ns

Electrical Characteristics

Over the Operating Range

Parameter	Description	Test Conditions	-10 (Industrial)		-12 (Automotive)		Unit	
			Min	Max	Min	Max		
V _{OH}	Output HIGH Voltage	V _{CC} = Min, I _{OH} = -4.0 mA	2.4	-	2.4	-	V	
		V _{CC} = Max, I _{OH} = -0.1mA	-	3.4 [4]	-	3.4 [4]		
V _{OL}	Output LOW Voltage	V _{CC} = Min, I _{OL} = 8.0 mA	-	0.4	-	0.4	V	
V _{IH}	Input HIGH Voltage		2.0	V _{CC} + 0.5	2.0	V _{CC} + 0.5	V	
V _{IL}	Input LOW Voltage [3]		-0.5	0.8	-0.5	0.8	V	
I _{IX}	Input Leakage Current	GND ≤ V _I ≤ V _{CC}	-1	+1	-1	+1	μA	
I _{OZ}	Output Leakage Current	GND ≤ V _{OUT} ≤ V _{CC} , Output Disabled	-1	+1	-1	+1	μA	
I _{CC}	V _{CC} Operating Supply Current	V _{CC} = Max, f = f _{MAX} = 1/t _{RC}	100 MHz	-	90	-	-	mA
			83 MHz	-	80	-	95	mA
			66 MHz	-	70	-	85	mA
			40 MHz	-	60	-	75	mA
I _{SB1}	Automatic CE Power-Down Current – TTL Inputs	Max V _{CC} , $\overline{CE} \geq V_{IH}$, V _{IN} ≥ V _{IH} or V _{IN} ≤ V _{IL} , f = f _{MAX}	-	20	-	25	mA	
I _{SB2}	Automatic CE Power-Down Current – CMOS Inputs	Max V _{CC} , $\overline{CE} \geq V_{CC} - 0.3$ V, V _{IN} ≥ V _{CC} - 0.3 V or V _{IN} ≤ 0.3 V, f = 0	-	10	-	15	mA	

Notes

- V_{IL} (Min) = -2.0 V and V_{IH} (max) = V_{CC} + 2 V for pulse durations of less than 20 ns.
- Please note that the maximum V_{OH} limit does not exceed minimum CMOS V_{IH} of 3.5 V. If you are interfacing this SRAM with 5V legacy processors that require a minimum V_{IH} of 3.5 V, please refer to Application Note [AN6081](#) for technical details and options you may consider.

Capacitance

Parameter [5]	Description	Test Conditions	Max	Unit
C_{IN}	Input capacitance	$T_A = 25\text{ }^\circ\text{C}$, $f = 1\text{ MHz}$, $V_{CC} = 5.0\text{ V}$	8	pF
C_{OUT}	I/O capacitance		8	pF

Thermal Resistance

Parameter [5]	Description	Test Conditions	44-pin SOJ Package	44-pin TSOP II Package	Unit
Θ_{JA}	Thermal resistance (junction to ambient)	Still Air, soldered on a 3 × 4.5 inch, four-layer printed circuit board	57.91	50.66	$^\circ\text{C/W}$
Θ_{JC}	Thermal resistance (junction to case)		36.73	17.17	$^\circ\text{C/W}$

AC Test Loads and Waveforms

Figure 2. AC Test Loads and Waveforms [6]

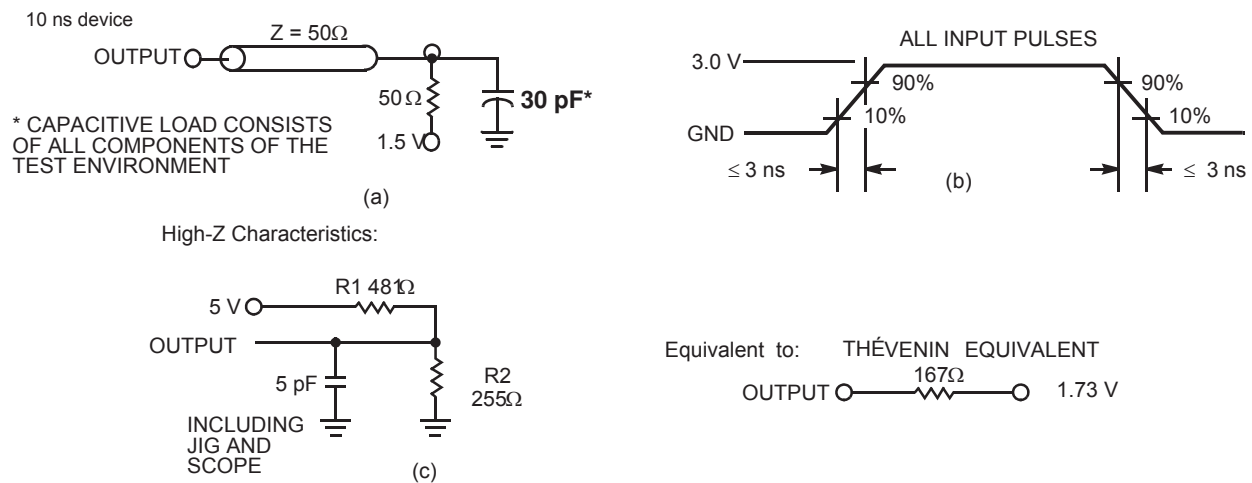

Notes

- 5. Tested initially and after any design or process changes that may affect these parameters.
- 6. AC characteristics (except High-Z) are tested using the load conditions shown in Figure 2 (a). High-Z characteristics are tested for all speeds using the test load shown in Figure 2 (c)

Data Retention Characteristics

Over the Operating Range

Parameter	Description	Conditions ^[7]	Min	Max	Unit	
V_{DR}	V_{CC} for Data Retention		2.0	–	V	
I_{CCDR}	Data Retention Current	$V_{CC} = V_{DR} = 2.0\text{ V}$, $\overline{CE} \geq V_{CC} - 0.3\text{ V}$, $V_{IN} \geq V_{CC} - 0.3\text{ V}$ or $V_{IN} \leq 0.3\text{ V}$	Industrial	–	10	mA
I_{CCDR}	Data Retention Current		Automotive	–	15	mA
$t_{CDR}^{[8]}$	Chip Deselect to Data Retention Time		0	–	ns	
$t_R^{[9]}$	Operation Recovery Time		t_{RC}	–	ns	

Data Retention Waveform

Figure 3. Data Retention Waveform

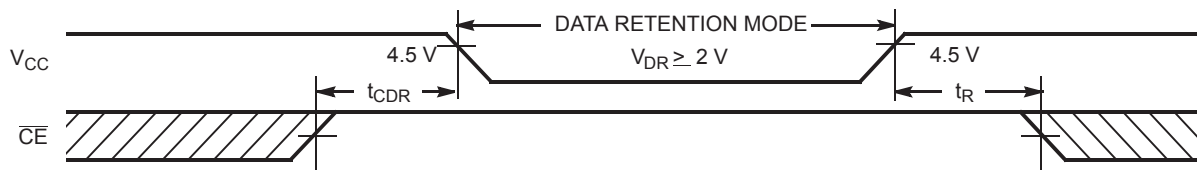

Notes

- 7. No input may exceed $V_{CC} + 0.5\text{ V}$.
- 8. Tested initially and after any design or process changes that may affect these parameters.
- 9. Full device operation requires linear V_{CC} ramp from V_{DR} to $V_{CC(\text{Min})} \geq 50\ \mu\text{s}$ or stable at $V_{CC(\text{Min})} \geq 50\ \mu\text{s}$.

Switching Characteristics

Over the Operating Range

Parameter ^[11]	Description	-10 (Industrial)		-12 (Automotive)		Unit
		Min	Max	Min	Max	
Read Cycle						
t_{power}	V_{CC} (typical) to the First Access ^[12]	100	–	100	–	μs
t_{RC}	Read Cycle Time	10	–	12	–	ns
t_{AA}	Address to Data Valid	–	10	–	12	ns
t_{OHA}	Data Hold from Address Change	3	–	3	–	ns
t_{ACE}	\overline{CE} LOW to Data Valid	–	10	–	12	ns
t_{DOE}	\overline{OE} LOW to Data Valid	–	5	–	6	ns
t_{LZOE}	\overline{OE} LOW to Low Z	0	–	0	–	ns
t_{HZOE}	\overline{OE} HIGH to High Z ^[13, 14]	–	5	–	6	ns
t_{LZCE}	\overline{CE} LOW to Low Z ^[14]	3	–	3	–	ns
t_{HZCE}	\overline{CE} HIGH to High Z ^[13, 14]	–	5	–	6	ns
t_{PU}	\overline{CE} LOW to Power-Up	0	–	0	–	ns
t_{PD}	\overline{CE} HIGH to Power-Down	–	10	–	12	ns
t_{DBE}	Byte Enable to Data Valid	–	5	–	6	ns
t_{LZBE}	Byte Enable to Low Z	0	–	0	–	ns
t_{HZBE}	Byte Disable to High Z	–	5	–	6	ns
Write Cycle ^[15, 16]						
t_{WC}	Write Cycle Time	10	–	12	–	ns
t_{SCE}	\overline{CE} LOW to Write End	7	–	10	–	ns
t_{AW}	Address Set-Up to Write End	7	–	10	–	ns
t_{HA}	Address Hold from Write End	0	–	0	–	ns
t_{SA}	Address Set-Up to Write Start	0	–	0	–	ns
t_{PWE}	\overline{WE} Pulse Width	7	–	10	–	ns
t_{SD}	Data Set-Up to Write End	6	–	7	–	ns
t_{HD}	Data Hold from Write End	0	–	0	–	ns
t_{LZWE}	\overline{WE} HIGH to Low Z ^[14]	3	–	3	–	ns
t_{HZWE}	\overline{WE} LOW to High Z ^[13, 14]	–	5	–	6	ns
t_{BW}	Byte Enable to End of Write	7	–	10	–	ns

Notes

- AC characteristics (except High-Z) are tested using the load conditions shown in Figure 2 (a). High-Z characteristics are tested for all speeds using the test load shown in Figure 2 (c).
- Test conditions assume signal transition time of 3 ns or less, timing reference levels of 1.5 V, input pulse levels of 0 to 3.0 V, and output loading of the specified I_{OL}/I_{OH} and 30-pF load capacitance.
- t_{power} gives the minimum amount of time that the power supply should be at typical V_{CC} values until the first memory access can be performed.
- t_{HZOE} , t_{HZCE} , t_{HZBE} , and t_{HZWE} are specified with a load capacitance of 5 pF as in part (c) of Figure 2. Transition is measured when the outputs enter a high impedance state.
- At any given temperature and voltage condition, t_{HZCE} is less than t_{LZCE} , t_{HZOE} is less than t_{LZOE} , t_{HZBE} is less than t_{LZBE} , and t_{HZWE} is less than t_{LZWE} for any given device.
- The internal Write time of the memory is defined by the overlap of \overline{CE} LOW, and \overline{WE} LOW. \overline{CE} and \overline{WE} must be LOW to initiate a Write, and the transition of either of these signals can terminate the Write. The input data set-up and hold timing should be referenced to the leading edge of the signal that terminates the Write.
- The minimum Write cycle time for Write Cycle No. 4 (\overline{WE} Controlled, \overline{OE} LOW) is the sum of t_{HZWE} and t_{SD} .

Switching Waveforms

Figure 4. Read Cycle No. 1 [17, 18]

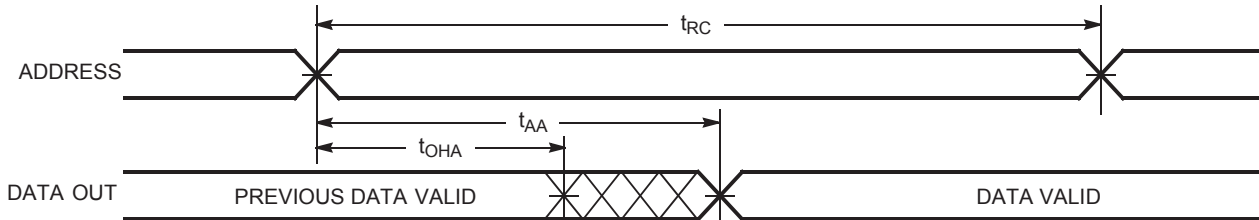
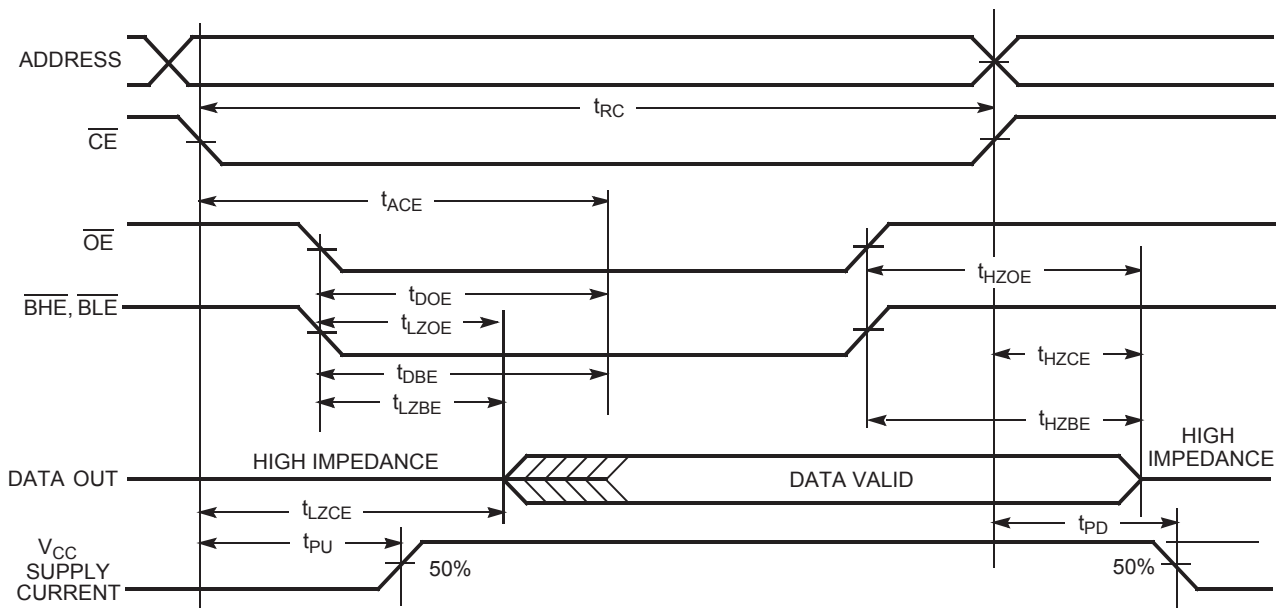

Figure 5. Read Cycle No. 2 (\overline{OE} Controlled) [19, 20]



Notes

- 17. No input may exceed $V_{CC} + 0.5$ V.
- 18. Device is continuously selected. \overline{OE} , \overline{CE} , \overline{BHE} , and/or \overline{BLE} = V_{IL} .
- 19. \overline{WE} is HIGH for read cycle.
- 20. Address valid prior to or coincident with \overline{CE} transition LOW.

Switching Waveforms(continued)

Figure 6. Write Cycle No. 1 ($\overline{\text{CE}}$ Controlled) [21, 22]

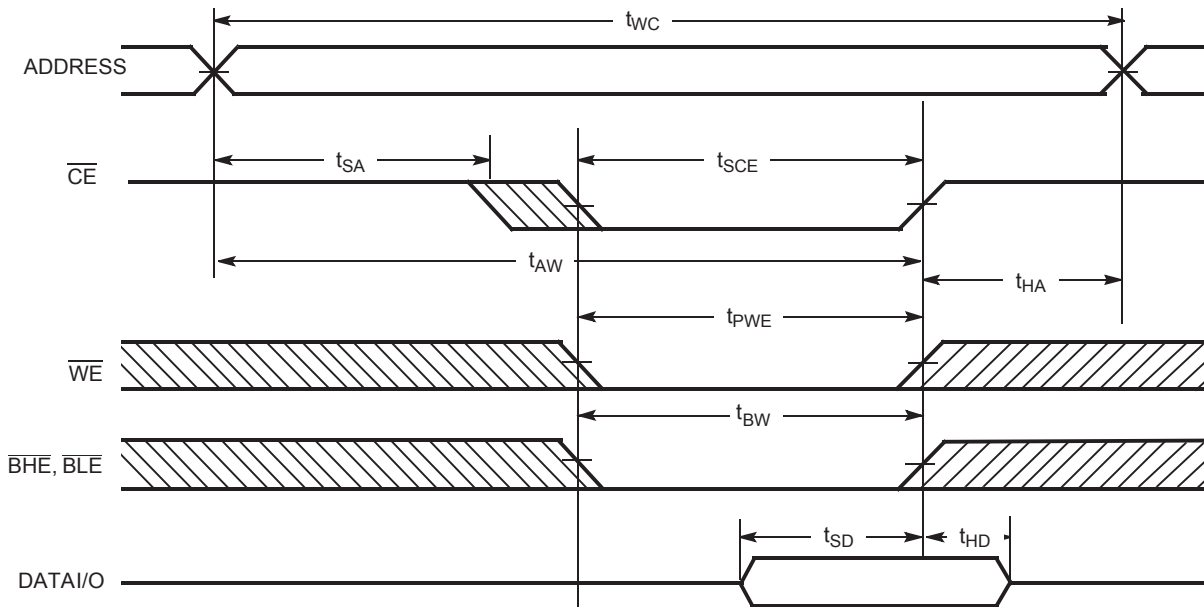
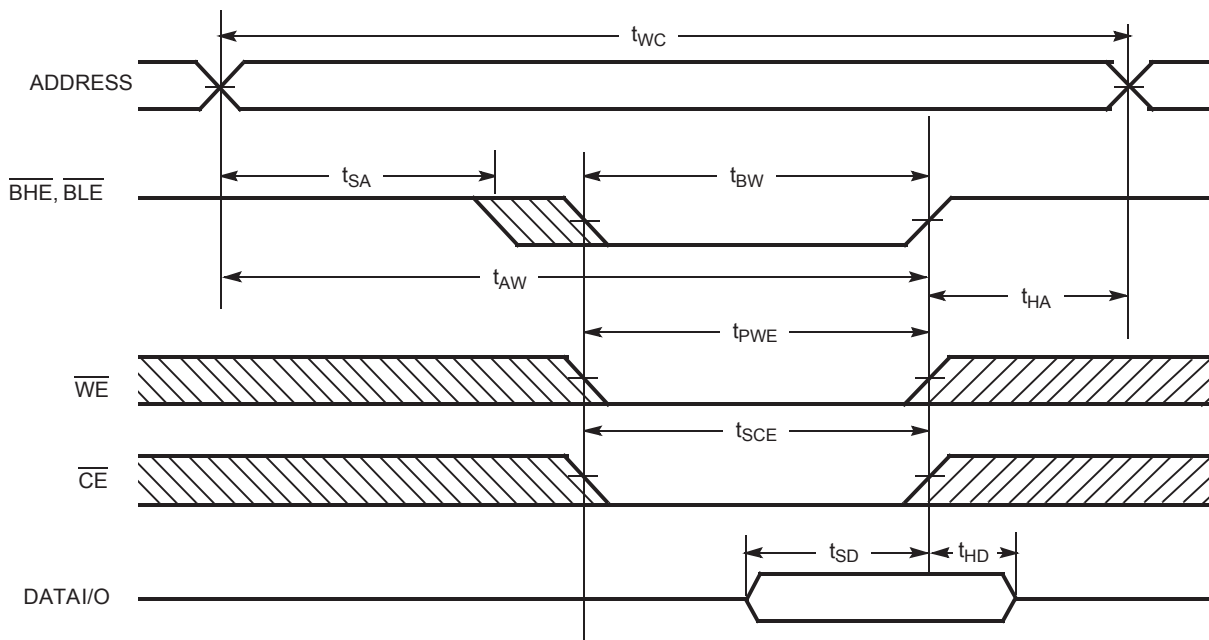

Figure 7. Write Cycle No. 2 ($\overline{\text{BLE}}$ or $\overline{\text{BHE}}$ Controlled)



Notes

21. Data I/O is high impedance if $\overline{\text{OE}}$ or $\overline{\text{BHE}}$ and/or $\overline{\text{BLE}} = V_{IH}$.

22. If $\overline{\text{CE}}$ goes HIGH simultaneously with $\overline{\text{WE}}$ going HIGH, the output remains in a high-impedance state.

Switching Waveforms(continued)

Figure 8. Write Cycle No. 3 (\overline{WE} Controlled, \overline{OE} HIGH During Write) [23, 24]

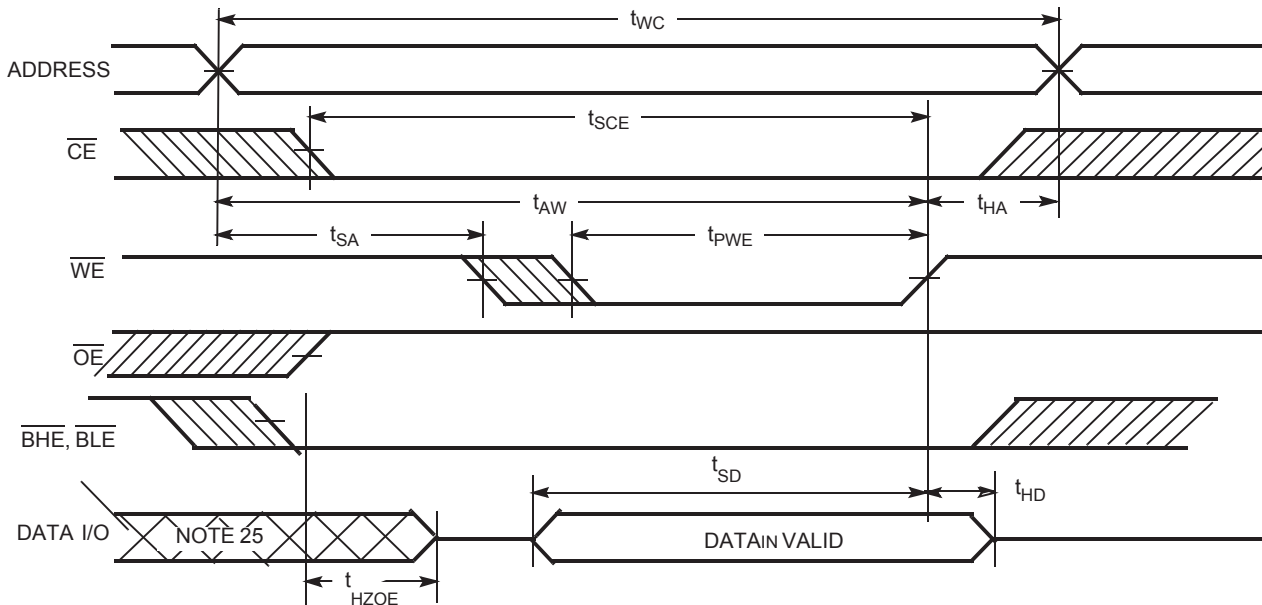
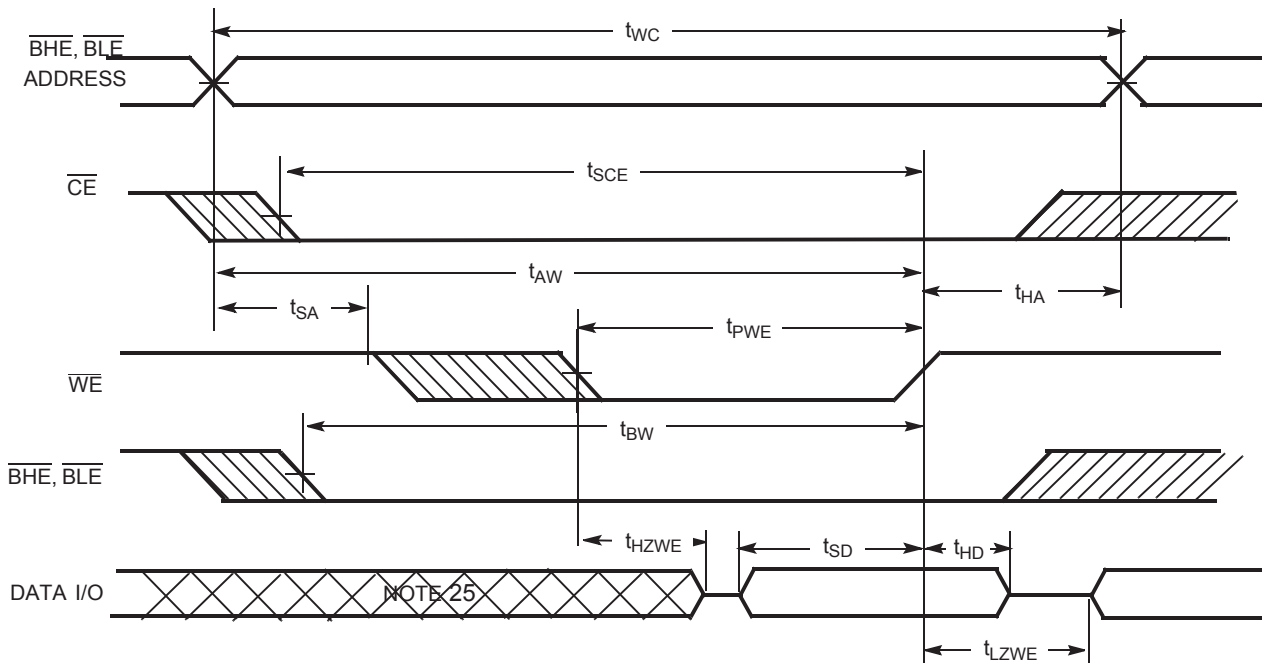

Figure 9. Write Cycle No. 4 (\overline{WE} Controlled, \overline{OE} LOW) [26]



Notes

- 23. Address valid prior to or coincident with \overline{CE} transition LOW.
- 24. Data I/O is high impedance if \overline{OE} or \overline{BHE} and/or $\overline{BLE} = V_{IH}$.
- 25. During this period the I/Os are in the output state and input signals should not be applied.
- 26. The minimum Write cycle time for Write Cycle No. 4 (\overline{WE} Controlled, \overline{OE} LOW) is the sum of t_{HZWE} and t_{SD} .

Truth Table

\overline{CE}	\overline{OE}	\overline{WE}	\overline{BLE}	\overline{BHE}	I/O ₀ -I/O ₇	I/O ₈ -I/O ₁₅	Mode	Power
H	X	X	X	X	High Z	High Z	Power Down	Standby (I _{SB})
L	L	H	L	L	Data Out	Data Out	Read All bits	Active (I _{CC})
L	L	H	L	H	Data Out	High Z	Read Lower bits only	Active (I _{CC})
L	L	H	H	L	High Z	Data Out	Read Upper bits only	Active (I _{CC})
L	X	L	L	L	Data In	Data In	Write All bits	Active (I _{CC})
L	X	L	L	H	Data In	High Z	Write Lower bits only	Active (I _{CC})
L	X	L	H	L	High Z	Data In	Write Upper bits only	Active (I _{CC})
L	H	H	X	X	High Z	High Z	Selected, Outputs Disabled	Active (I _{CC})

Ordering Information

Table 1 lists the CY7C1041D key package features and ordering codes. The table contains only the parts that are currently available. If you do not see what you are looking for, contact your local sales representative. For more information, visit the Cypress website at www.cypress.com and refer to the product summary page at <http://www.cypress.com/products>.

Table 1. Key Features and Ordering Information

Speed (ns)	Ordering Code	Package Diagram	Package Type	Operating Range
10	CY7C1041D-10VXI	51-85082	44-pin SOJ (400 Mils) Pb-free	Industrial
	CY7C1041D-10ZSXI	51-85087	44-pin TSOP (Type II) Pb-free	

Ordering Code Definitions

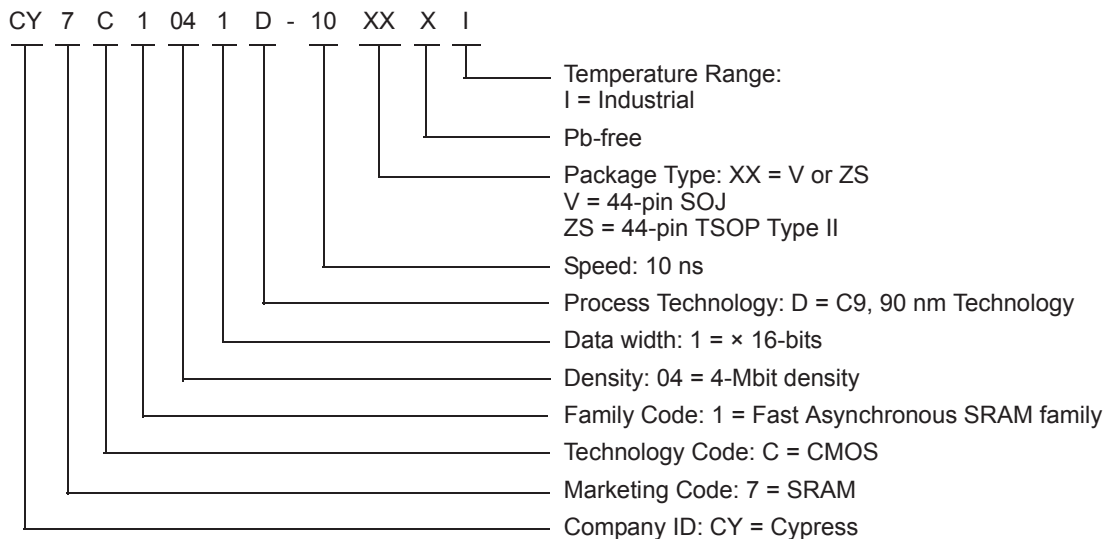

Package Diagrams

Figure 10. 44-pin SOJ (400 Mils) V44.4 Package Outline, 51-85082

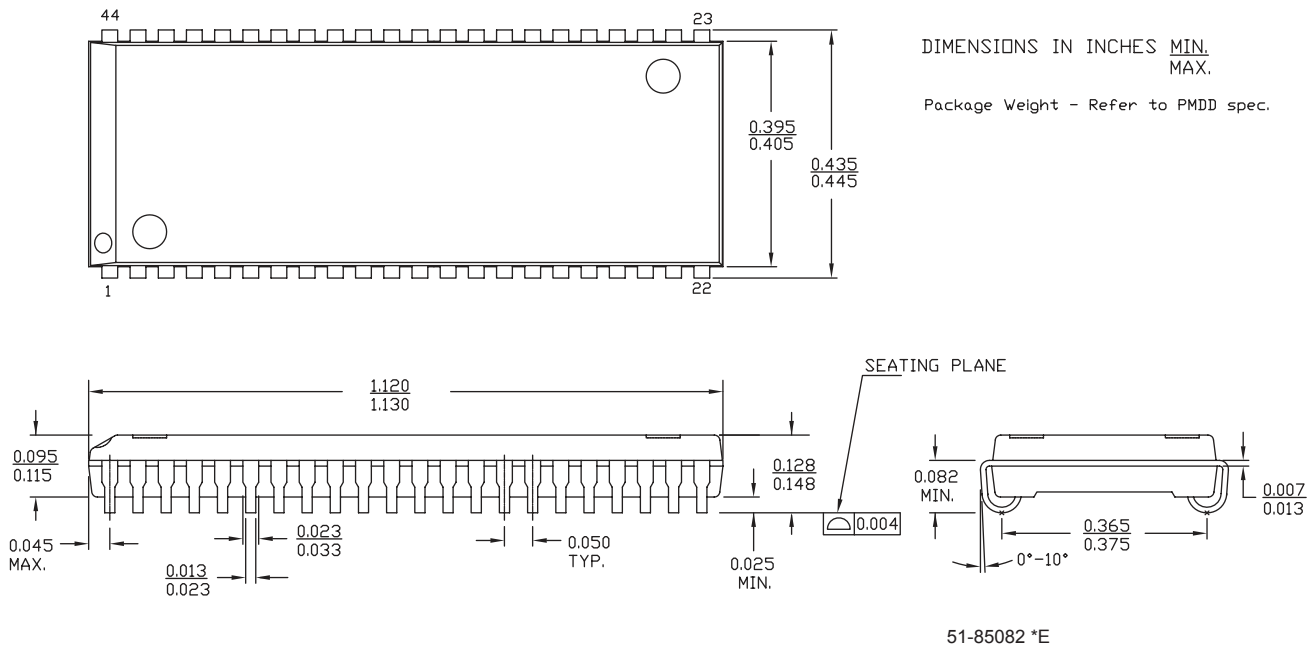
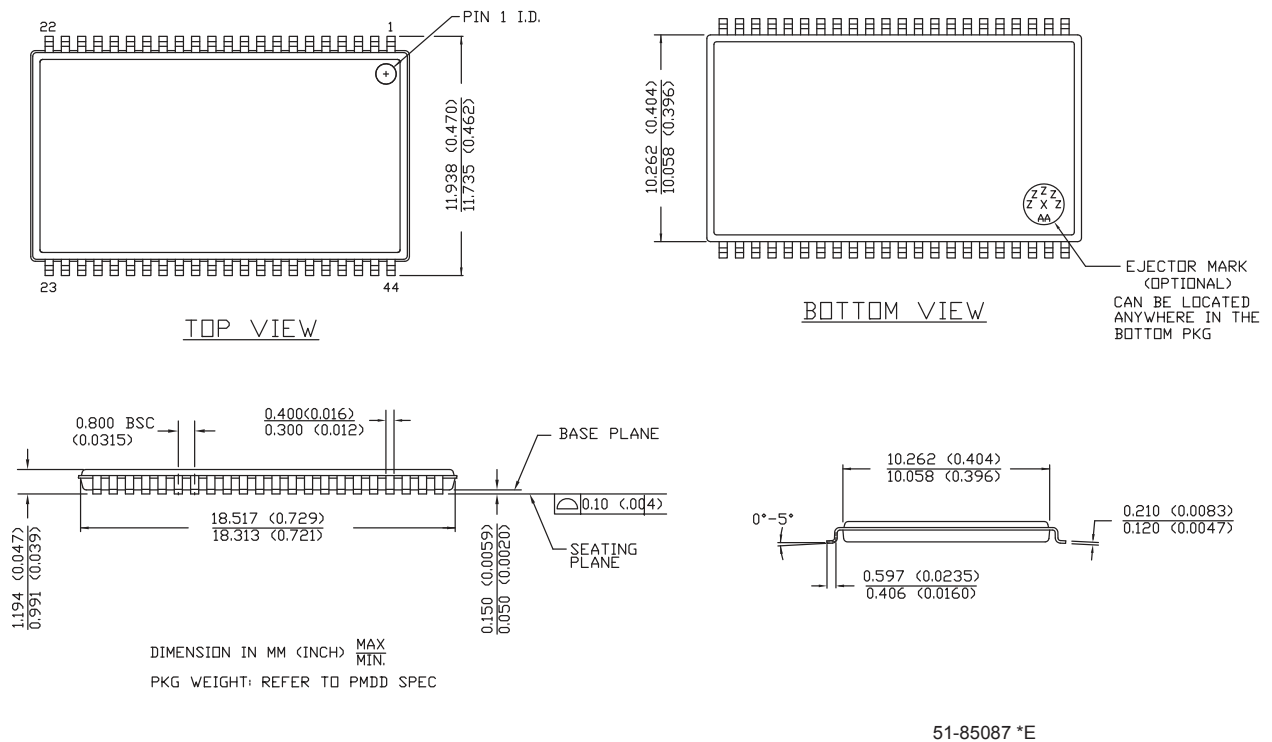

Figure 11. 44-pin TSOP Z44-II Package Outline, 51-85087



Acronyms

Acronym	Description
CE	Chip Enable
CMOS	Complementary Metal Oxide Semiconductor
I/O	Input/Output
OE	Output Enable
SRAM	Static Random Access Memory
SOJ	Small Outline J-Lead
TSOP	Thin Small Outline Package
VFBGA	Very Fine-Pitch Ball Grid Array

Document Conventions

Units of Measure

Symbol	Unit of Measure
°C	degree Celsius
MHz	megahertz
μA	microampere
mA	milliampere
mV	millivolt
mW	milliwatt
ns	nanosecond
pF	picofarad
V	volt
W	watt

Document History Page

Document Title: CY7C1041D, 4-Mbit (256 K × 16) Static RAM				
Document Number: 38-05472				
Revision	ECN	Orig. of Change	Submission Date	Description of Change
**	201560	SWI	See ECN	Advance Datasheet for C9 IPP
*A	233729	RKF	See ECN	1.AC, DC parameters are modified as per EROS (Spec #01-2165) 2.Pb-free offering in the 'ordering information'
*B	351117	PCI	See ECN	Changed from Advance to Preliminary Removed 17 and 20 ns Speed bin Added footnote # 4 Redefined I _{CC} values for Com'l and Ind'l temperature ranges I _{CC} (Com'l): Changed from 67 and 54 mA to 75 and 70 mA for 12 and 15 ns speed bins respectively I _{CC} (Ind'l): Changed from 80, 67 and 54 mA to 90, 85 and 80 mA for 10, 12 and 15 ns speed bins respectively Changed footnote # 10 on t _R Changed t _{SCE} from 8 to 7 ns for 10 ns speed bin Added Static Discharge Voltage and latch-up current spec Added V _{IH(max)} spec in footnote # 2 Changed reference voltage level for measurement of Hi-Z parameters from ±500 mV to ±200 mV Added Write Cycle (\overline{WE} Controlled, \overline{OE} HIGH During Write) Timing Diagram Changed part names from Z to ZS in the Ordering Information Table Removed L-Version Added 10 ns parts in the Ordering Information Table Added Lead-Free Ordering Information Shaded Ordering Information Table
*C	446328	NXR	See ECN	Converted Preliminary to Final Removed -15 speed bin Removed Commercial Operating Range product information Added Automotive Operating Range product information Changed Maximum Rating for supply voltage from 7 V to 6 V Updated Thermal Resistance table Changed t _{HZWE} from 6 ns to 5 ns Updated footnote #8 on High-Z parameter measurement Updated the Ordering Information and replaced Package Name column with Package Diagram in the Ordering Information table
*D	2897049	VKN	03/22/10	Removed inactive parts from the ordering information table.
*E	3109184	AJU	12/13/2010	Added Ordering Code Definitions .
*F	3236731	PRAS	04/21/2011	Template updates. Added acronyms and units tables.
*G	4040855	MEMJ	06/27/2013	Updated Functional Description . Updated Electrical Characteristics : Added one more Test Condition "V _{CC} = Max, I _{OH} = -0.1mA" for V _{OH} parameter and added maximum value corresponding to that Test Condition. Added Note 4 and referred the same note in maximum value for V _{OH} parameter corresponding to Test Condition "V _{CC} = Max, I _{OH} = -0.1mA". Updated Package Diagrams : spec 51-85082 – Changed revision from *C to *E. spec 51-85087 – Changed revision from *C to *E. Updated in new template.

Document History Page(continued)

Document Title: CY7C1041D, 4-Mbit (256 K x 16) Static RAM Document Number: 38-05472				
Revision	ECN	Orig. of Change	Submission Date	Description of Change
*H	4390998	MEMJ	05/27/2014	Updated Switching Characteristics : Updated Note 16 (Replaced "Write Cycle No. 3" with "Write Cycle No. 4"). Updated Switching Waveforms : Added Note 26 and referred the same note in Figure 9 . Completing Sunset Review.
*I	4578500	MEMJ	11/24/2014	Added related documentation hyperlink in page 1.

Sales, Solutions, and Legal Information

Worldwide Sales and Design Support

Cypress maintains a worldwide network of offices, solution centers, manufacturer's representatives, and distributors. To find the office closest to you, visit us at [Cypress Locations](#).

Products

Automotive	cypress.com/go/automotive
Clocks & Buffers	cypress.com/go/clocks
Interface	cypress.com/go/interface
Lighting & Power Control	cypress.com/go/powerpsoc cypress.com/go/plc
Memory	cypress.com/go/memory
PSoC	cypress.com/go/psoc
Touch Sensing	cypress.com/go/touch
USB Controllers	cypress.com/go/USB
Wireless/RF	cypress.com/go/wireless

PSoC[®] Solutions

psoc.cypress.com/solutions
PSoC 1 | PSoC 3 | PSoC 4 | PSoC 5LP

Cypress Developer Community

[Community](#) | [Forums](#) | [Blogs](#) | [Video](#) | [Training](#)

Technical Support

cypress.com/go/support

© Cypress Semiconductor Corporation, 2004-2014. The information contained herein is subject to change without notice. Cypress Semiconductor Corporation assumes no responsibility for the use of any circuitry other than circuitry embodied in a Cypress product. Nor does it convey or imply any license under patent or other rights. Cypress products are not warranted nor intended to be used for medical, life support, life saving, critical control or safety applications, unless pursuant to an express written agreement with Cypress. Furthermore, Cypress does not authorize its products for use as critical components in life-support systems where a malfunction or failure may reasonably be expected to result in significant injury to the user. The inclusion of Cypress products in life-support systems application implies that the manufacturer assumes all risk of such use and in doing so indemnifies Cypress against all charges.

Any Source Code (software and/or firmware) is owned by Cypress Semiconductor Corporation (Cypress) and is protected by and subject to worldwide patent protection (United States and foreign), United States copyright laws and international treaty provisions. Cypress hereby grants to licensee a personal, non-exclusive, non-transferable license to copy, use, modify, create derivative works of, and compile the Cypress Source Code and derivative works for the sole purpose of creating custom software and or firmware in support of licensee product to be used only in conjunction with a Cypress integrated circuit as specified in the applicable agreement. Any reproduction, modification, translation, compilation, or representation of this Source Code except as specified above is prohibited without the express written permission of Cypress.

Disclaimer: CYPRESS MAKES NO WARRANTY OF ANY KIND, EXPRESS OR IMPLIED, WITH REGARD TO THIS MATERIAL, INCLUDING, BUT NOT LIMITED TO, THE IMPLIED WARRANTIES OF MERCHANTABILITY AND FITNESS FOR A PARTICULAR PURPOSE. Cypress reserves the right to make changes without further notice to the materials described herein. Cypress does not assume any liability arising out of the application or use of any product or circuit described herein. Cypress does not authorize its products for use as critical components in life-support systems where a malfunction or failure may reasonably be expected to result in significant injury to the user. The inclusion of Cypress' product in a life-support systems application implies that the manufacturer assumes all risk of such use and in doing so indemnifies Cypress against all charges.

Use may be limited by and subject to the applicable Cypress software license agreement.