

2.5W/Ch Stereo Class D Audio Power Amplifier

General Description

The AAT5102 is a high efficiency, high performance stereo class D audio amplifier. It is designed to operate in a wide supply voltage range from 2.5V to 5.5V and is targeted to deliver up to 2.5W output power to a 4Ω load with × 5V power supply. Efficiency of up to 90.5% makes it ideal for portable applications.

The AAT5102 has four adjustable amplifier gains with 6, 12, 18 and 24dB programmed by two external pins. Two shutdown control pins are employed to control the left and right channels independently.

The AAT5102 also integrates over-temperature protection circuitry to prevent internal junction temperature over-heating.

The AAT5102 is offered in a Pb-free, thermally enhanced, space-saving 1.645mm × 1.645mm 16-pin WLCSP package and in the 3mm × 3mm 16-pin QFN package, and is specified for operation over the -40°C to +85°C ambient temperature range.

Features

- Wide Supply Voltage Range (2.5V to 5.5V)
- Maximum Battery Life and Minimum Heat
 - 5mA Quiescent Current at 3.6V V_{DD}
 - <1μA Shutdown Current
 - Up to 90.5% Efficiency
- Output Power at 10% THD+N
 - 2.5W x2 to 4Ω at 5V V_{DD}
 - 1.6W x2 to 8Ω at 5V V_{DD}
- High Performance
 - THD+N of 0.03%, at 5V V_{DD} , 8Ω Load and $P_{OUT} = 1.0W$
 - SNR of 102dB at 5V V_{DD} , 8Ω Load and 1% THD+N
- Shutdown Control
 - Independent Control per Channel¹
 - Internal 300kΩ Pull-down Resistors
- Filter-less Capability
- Four Programmable Gains: 6, 12, 18 and 24dB
- Thermal Protection
- Excellent PSRR
- Built-in Pop-click Suppression Circuitry
- 1.645mm × 1.645mm 16-Pin WLCSP Package
- 3mm × 3mm 16-Pin QFN Package

Applications

- Cellular Phones
- MP4s
- Notebook Computers
- PDAs
- Portable DVD Players

Typical Application

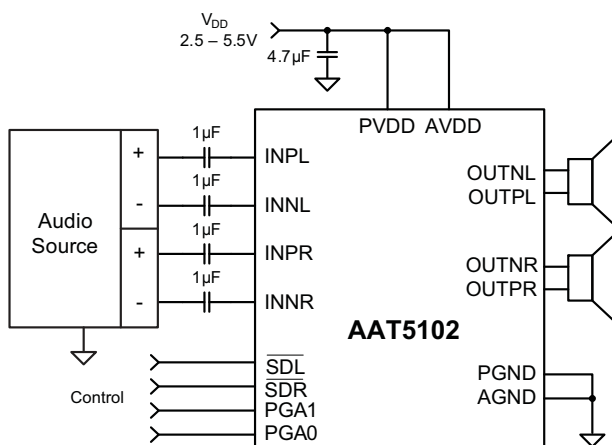

1. When independent control is used, the device ground and the audio source ground should be connected together.

AAT5102

2.5W/Ch Stereo Class D Audio Power Amplifier

Pin Descriptions

Pin Number		Symbol	Description
WLCSP-16	QFN33-16		
A1	16	INPL	Analog positive input, left channel
B1	15	INNLL	Analog negative input, left channel
D1	13	INPR	Analog positive input, right channel
C1	14	INNRR	Analog negative input, right channel
A3	3	OUTPL	Power stage positive output, left channel
A4	4	OUTNL	Power stage negative output, left channel
D3	10	OUTPR	Power stage positive output, right channel
D4	9	OUTNR	Power stage negative output, right channel
C2	12	PGA1	PGA gain control, TTL compatible
B2	1	PGA0	PGA gain control, TTL compatible
C3	8	SDR	Right channel shutdown control (active low)
B3	5	SDL	Left channel shutdown control (active low)
D2	11	AVDD	Analog power supply
B4	6	PVDD	Power supply for output drivers
A2	2	AGND	Analog power ground
C4	7	PGND	Power ground for output drivers

Pin Configuration

**WLCSP-16
(Top View)**

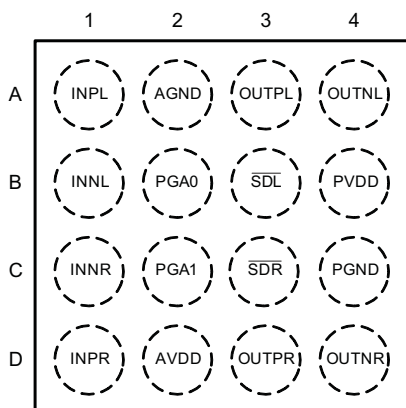

**QFN33-16
(Top View)**

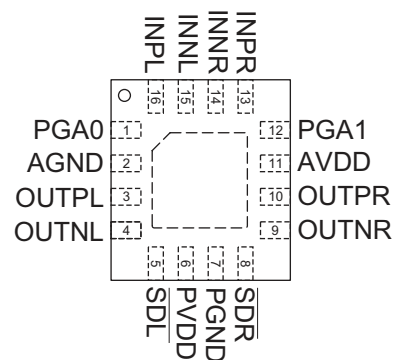

2.5W/Ch Stereo Class D Audio Power Amplifier

Absolute Maximum Ratings¹

Symbol	Description	Value	Units
V _{DD}	Supply Voltage	-0.3 to 6.0	V
V _{IN}	Digital Input to Ground ($\overline{\text{SDR}}$, $\overline{\text{SDL}}$, PGA1 and PGA0 Pins)	-0.3 to V _{DD} +0.3	
T _J	Maximum Junction Operating Temperature Range	-40 to +150	°C
T _{LEAD}	Maximum Soldering Temperature (at leads, 10 sec)	300	
T _{STG}	Storage Temperature Range	-65 to 150	

Recommended Operating Conditions

Symbol	Description	Min	Max	Unit
V _{DD}	Supply Voltage	2.5	5.5	V
V _{IH}	High-level Input Voltage	1.5	V _{DD}	
V _{IL}	Low-level Input Voltage	0	0.5	
T _A	Operating Temperature	-40	85	°C

Thermal Information²

Symbol	Description		Value	Units
Θ _{JA}	Thermal Resistance	WLCSP-16	90.4	°C/W
		QFN33-16	50	
P _D	Maximum Power Dissipation	WLCSP-16	1.1	W
		QFN33-16	2	

1. Stresses above those listed in Absolute Maximum Ratings may cause permanent damage to the device. Functional operation at conditions other than the operating conditions specified is not implied. Only one Absolute Maximum Rating should be applied at any one time.
2. Mounted on 1.6mm thick FR4 material printed circuit board.

DATA SHEET

AAT5102

2.5W/Ch Stereo Class D Audio Power Amplifier

Electrical Characteristics

$V_{DD}=5.0V$, $C_S=4.7\mu F$, $C_I=1\mu F$, $R_L=8\Omega$ and Gain=6dB. $T_A = 25^\circ C$ unless otherwise noted.

Symbol	Description	Conditions	Min	Typ	Max	Units
DC Characteristics						
V_{DD}	Supply Voltage		2.5		5.5	V
V_{OS}	Output Offset Voltage	Room Temperature Only	-25	5	25	mV
I_Q	Operation Quiescent Current	$V_{DD} = 5.5V$, $\overline{SDR} = \overline{SDL} = \text{high}$, No Load		6.5	10	mA
		$V_{DD} = 3.6V$, $\overline{SDR} = \overline{SDL} = \text{high}$, No Load		5	8	
		$V_{DD} = 2.5V$, $\overline{SDR} = \overline{SDL} = \text{high}$, No Load		4.5	7	
$I_{SD(OFF)}$	Shutdown Supply Current	$\overline{SDR} = \overline{SDL} = \text{low}$, No load	-1	0.1	1	μA
R_I	Input Impedance	PGA1 = low, PGA0 = low		28		k Ω
		PGA1 = low, PGA0 = high		14		
		PGA1 = high, PGA0 = low		28		
		PGA1 = high, PGA0 = high		14		
Gain	Amplifier Closed Loop Voltage Gain	PGA1 = low, PGA0 = low	5.3	6	6.7	dB
		PGA1 = low, PGA0 = high	11.3	12	12.7	
		PGA1 = high, PGA0 = low	17.3	18	18.7	
		PGA1 = high, PGA0 = high	23.3	24	24.7	
$R_{\overline{SD}}$	Resistance from $\overline{SDR}/\overline{SDL}$ to GND			300		k Ω
V_{IH}	High-level Input Voltage	\overline{SDR} , \overline{SDL} , PGA1, PGA0	1.5			V
V_{IL}	Low-level Input Voltage	\overline{SDR} , \overline{SDL} , PGA1, PGA0			0.5	V
T_{SD}	Over-Temperature Shutdown Threshold			145		$^\circ C$
T_{HYS}	Over-Temperature Shutdown Hysteresis			15		$^\circ C$
AC Characteristics						
F_{SW}	Switch Frequency			350		kHz
P_{OUT}	Output Power	THD+N = 10%, f = 1kHz, $R_L = 8\Omega$	$V_{DD} = 5.0V$	1.61		W
			$V_{DD} = 3.6V$	0.82		
		THD+N = 1%, f = 1kHz, $R_L = 8\Omega$	$V_{DD} = 5.0V$	1.31		
			$V_{DD} = 3.6V$	0.66		
		THD+N = 10%, f = 1kHz, $R_L = 4\Omega$	$V_{DD} = 5.0V$	2.66		
			$V_{DD} = 3.6V$	1.35		
		THD+N = 1%, f = 1kHz, $R_L = 4\Omega$	$V_{DD} = 5.0V$	2.13		
			$V_{DD} = 3.6V$	1.08		
η	Output Power Efficiency	$V_{DD} = 5.0V$, f = 1kHz, $P_{OUT} = 1.2W$		90.5		%
THD+N	Total Harmonic Distortion + Noise	f = 1kHz, $R_L = 8\Omega$, Gain = 6dB	$V_{DD} = 5.0V$, $P_{OUT} = 1W$	0.03		%
			$V_{DD} = 3.6V$, $P_{OUT} = 0.5W$	0.04		
V_{NO}	Noise Output Voltage	$V_{DD} = 3.6V$, f = 20Hz~20kHz, Inputs AC-grounded		26		μV
SNR	Signal to Noise Ratio	$V_{DD} = 5.0V$, f = 1kHz, THD+N = 1%		102		dB
PSRR	Power Supply Ripple Rejection Ratio	$V_{DD} = 3.6V$, $V_{RIPPLE} = 200mV_{pp}$, f = 217Hz, Inputs AC-grounded		-60		dB
CMRR	Common Mode Ripple Rejection Ratio	$V_{DD} = 3.6V$, $V_{RIPPLE} = 1V_{pp}$, f = 217Hz		-53		dB
T_{ON}	Turn-On Time			8		ms
T_{OFF}	Turn-Off Time			12		

AAT5102

2.5W/Ch Stereo Class D Audio Power Amplifier

Test Set-up for Typical Characteristics Graphs (per channel)

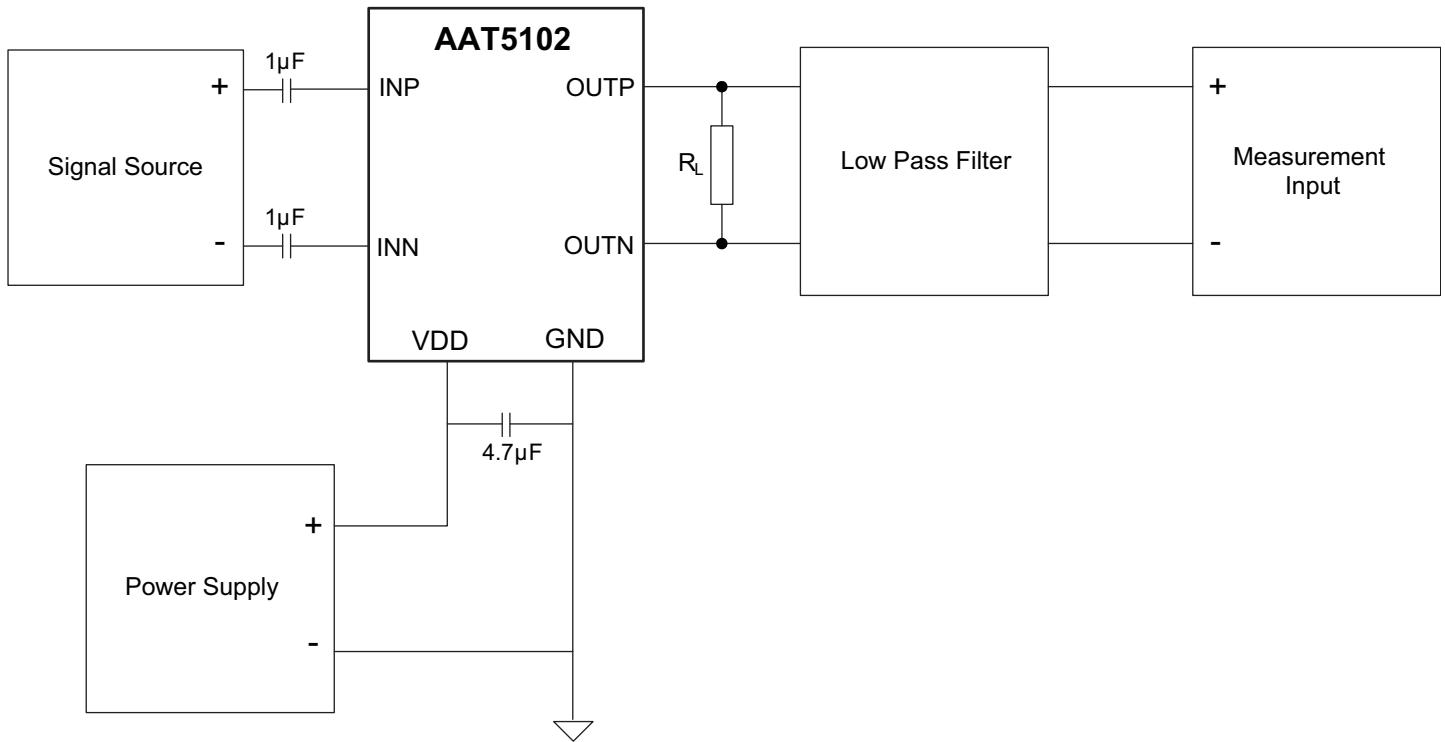

AAT5102

2.5W/Ch Stereo Class D Audio Power Amplifier

Typical Characteristics

Operation Quiescent Current vs. Temperature
(f = 1kHz, R_L = 4Ω)

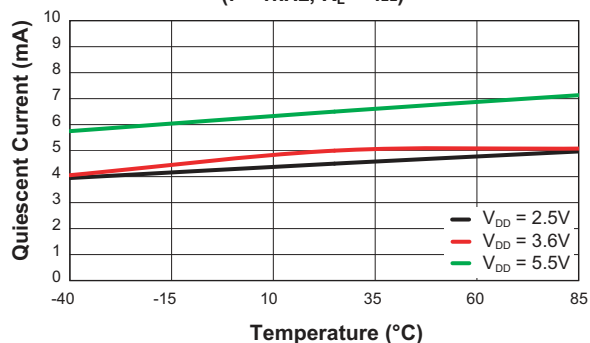

Quiescent Current vs. Supply Voltage (No Load)

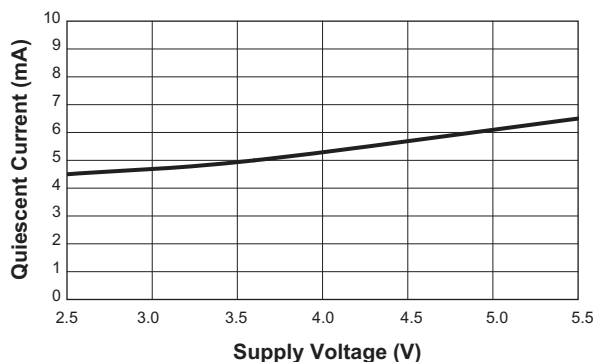

Shutdown Supply Current vs. Temperature
(f = 1kHz, R_L = 8Ω)

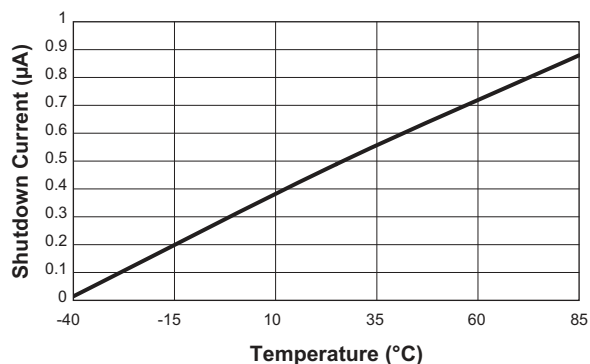

Switching Frequency vs. Input Voltage

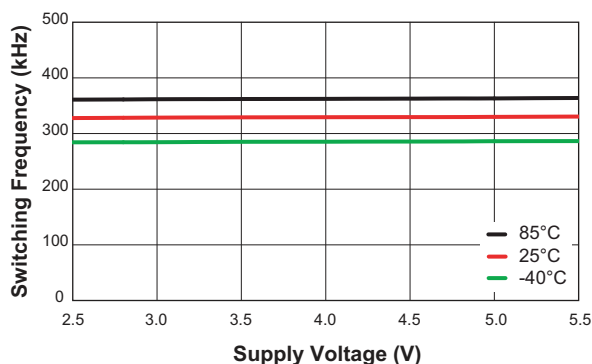

Efficiency vs. Output Power
(f = 1kHz; R_L = 4Ω + 33µH; Gain = 6dB)

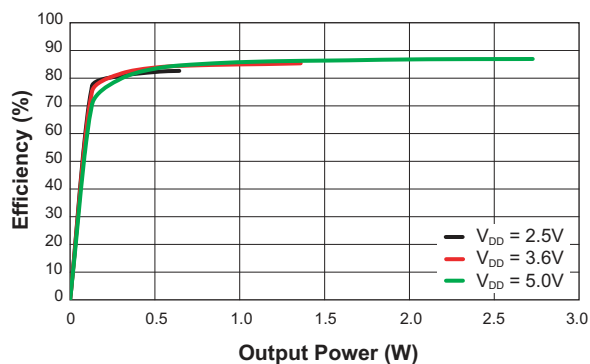

Efficiency vs. Output Power
(f = 1kHz; R_L = 8Ω + 33µH; Gain = 6dB)

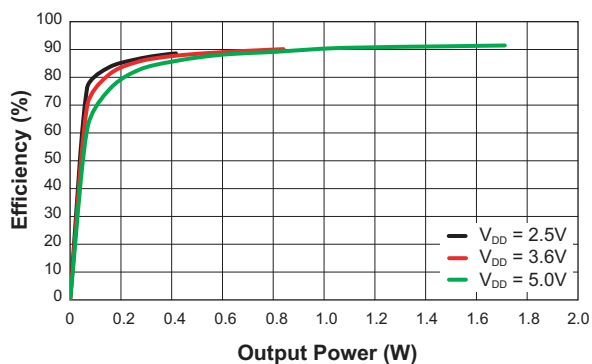

2.5W/Ch Stereo Class D Audio Power Amplifier

Typical Characteristics

Supply Current vs. Output Power
(f = 1kHz; R_L = 4Ω + 33μH; Gain = 6dB)

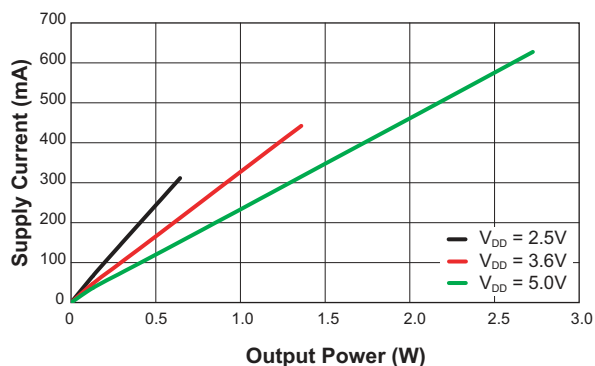

Supply Current vs. Output Power
(f = 1kHz; R_L = 8Ω + 33μH; Gain = 6dB)

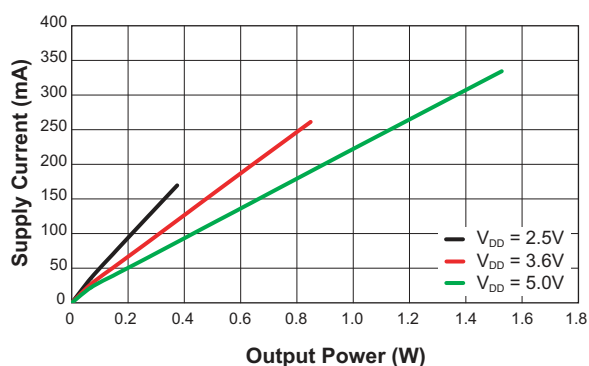

THD+N vs. Output Power
(f = 1kHz; R_L = 4Ω; Gain = 6dB)

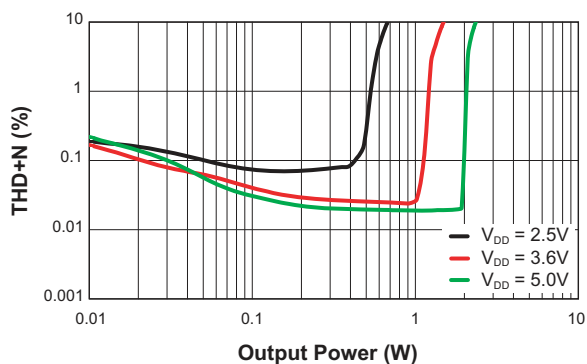

THD+N vs. Output Power
(f = 1kHz; R_L = 8Ω; Gain = 6dB)

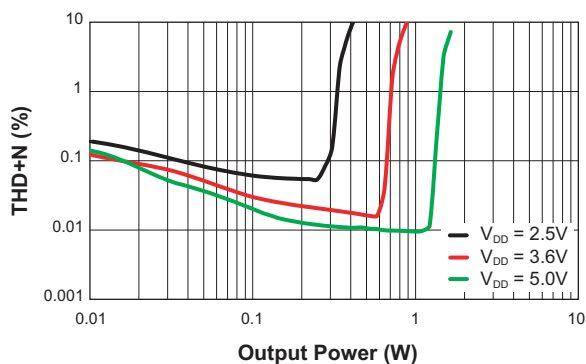

THD+N vs. Output Power
(f = 1kHz; R_L = 4Ω; Gain = 24dB)

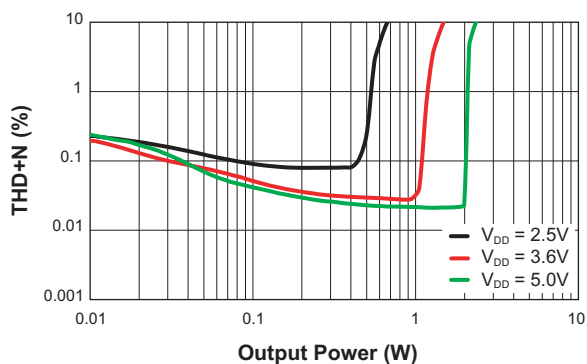

THD+N vs. Output Power
(f = 1kHz; R_L = 8Ω; Gain = 24dB)

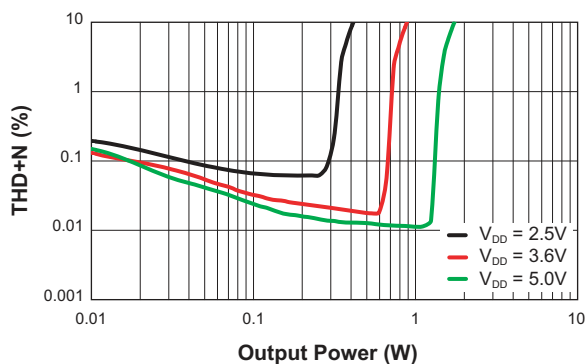

2.5W/Ch Stereo Class D Audio Power Amplifier

Typical Characteristics

THD+N vs. Frequency
($V_{DD} = 2.5V$; $R_L = 4\Omega$; Gain = 6dB)

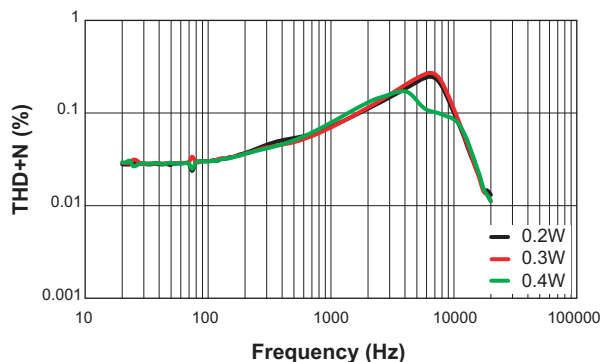

THD+N vs. Frequency
($V_{DD} = 2.5V$; $R_L = 8\Omega$; Gain = 6dB)

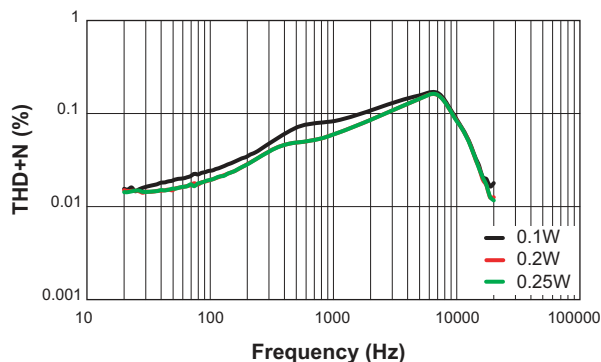

THD+N vs. Frequency
($V_{DD} = 3.6V$; $R_L = 4\Omega$; Gain = 6dB)

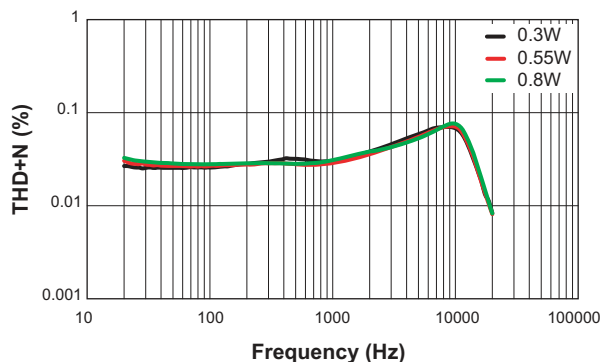

THD+N vs. Frequency
($V_{DD} = 3.6V$; $R_L = 8\Omega$; Gain = 6dB)

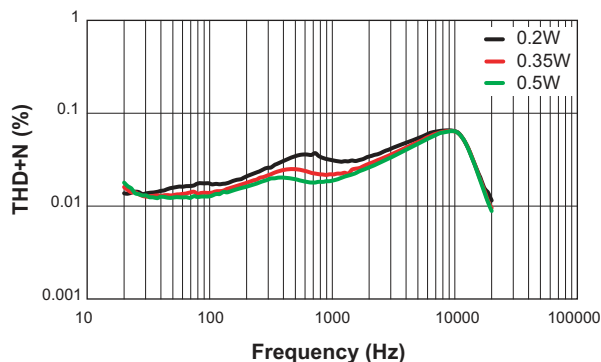

THD+N vs. Frequency
($V_{DD} = 5.0V$; $R_L = 4\Omega$; Gain = 6dB)

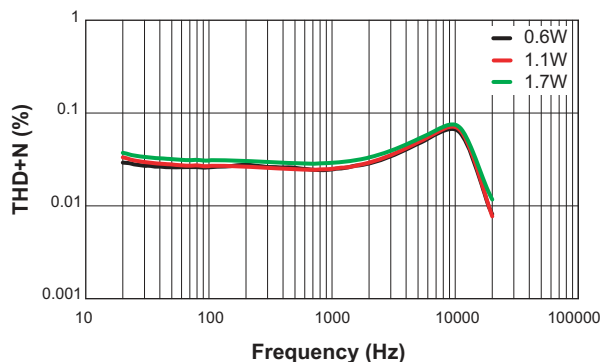

THD+N vs. Frequency
($V_{DD} = 5.0V$; $R_L = 8\Omega$; Gain = 6dB)

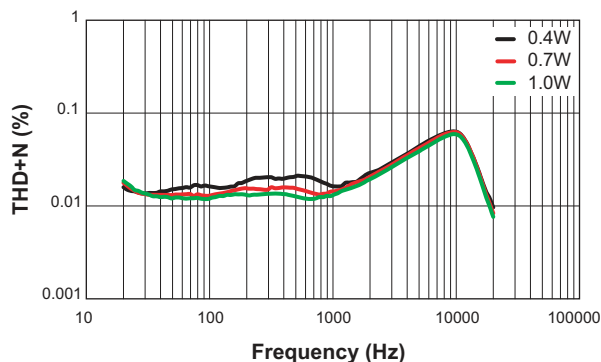

2.5W/Ch Stereo Class D Audio Power Amplifier

Typical Characteristics

CMRR vs. Frequency
($V_{CH} = 1V_{PP}$; $R_L = 4\Omega$; Gain = 6dB)

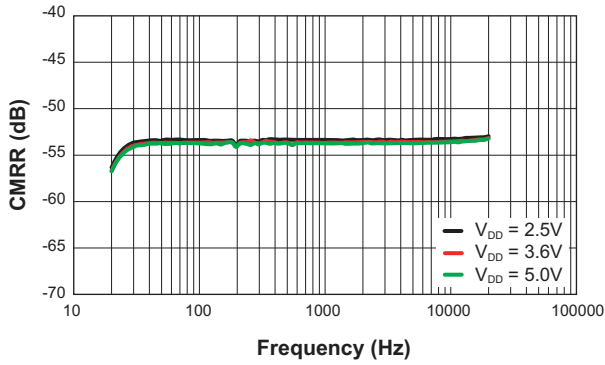

CMRR vs. Frequency
($V_{CH} = 1V_{PP}$; $R_L = 8\Omega$; Gain = 6dB)

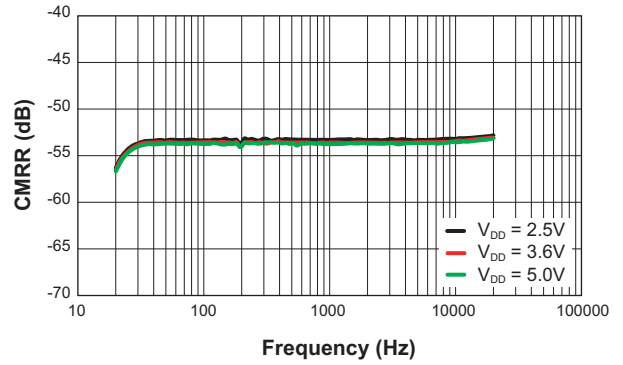

PSRR vs. Frequency
($V_{RIPPLE} = 200mV_{pp}$; $R_L = 4\Omega$; Gain = 6dB; Inputs AC Grounded)

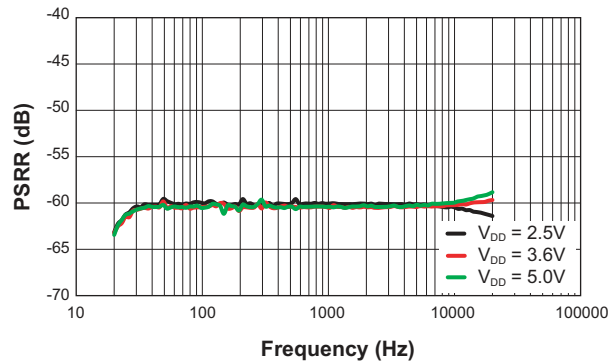

PSRR vs. Frequency
($V_{RIPPLE} = 200mV_{pp}$; $R_L = 8\Omega$; Gain = 6dB; Inputs AC Grounded)

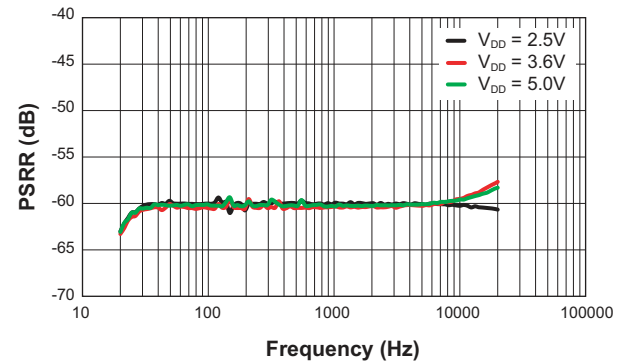

Noise Floor
($R_L = 8\Omega$; Gain = 6dB; Inputs AC Grounded; A weighting)

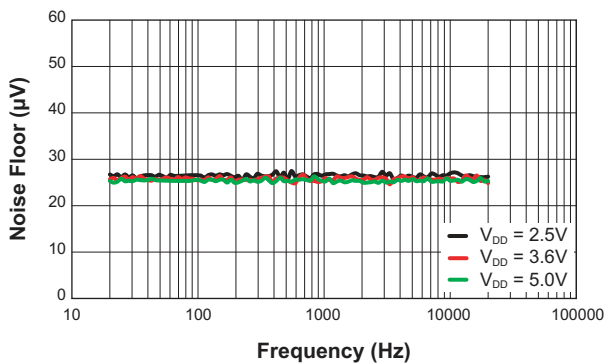

2.5W/Ch Stereo Class D Audio Power Amplifier

Typical Characteristics

Crosstalk vs. Frequency

($V_{IN} = 0.5V_{RMS}$; $R_L = 4\Omega$; Gain = 6dB; Left to Right)

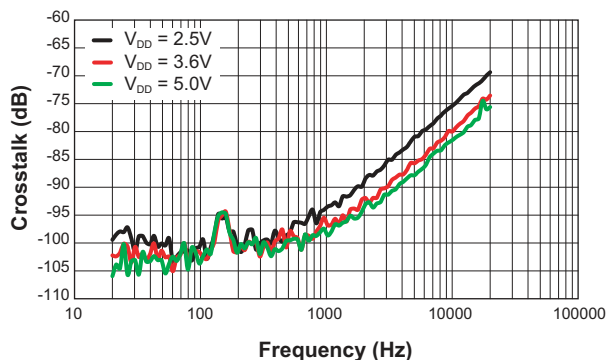

Crosstalk vs. Frequency

($V_{IN} = 0.5V_{RMS}$; $R_L = 4\Omega$; Gain = 6dB; Right to Left)

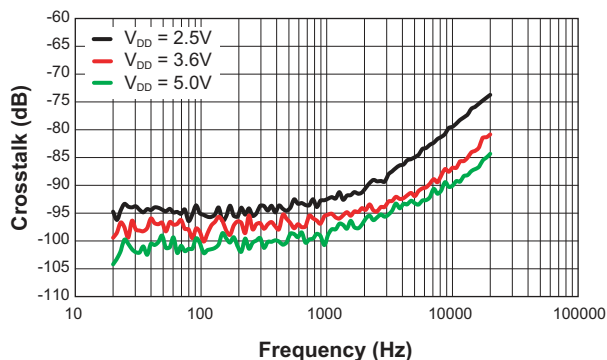

Crosstalk vs. Frequency

($V_{IN} = 0.5V_{RMS}$; $R_L = 8\Omega$; Gain = 6dB; Left to Right)

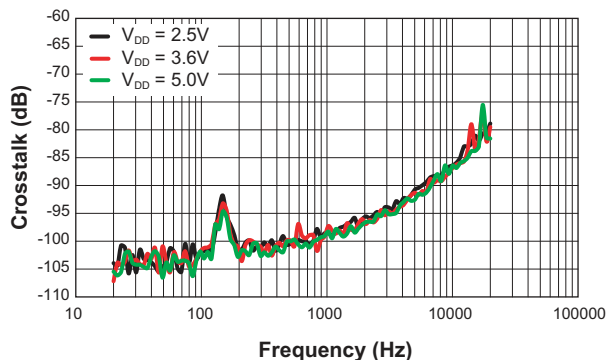

Crosstalk vs. Frequency

($V_{IN} = 0.5V_{RMS}$; $R_L = 8\Omega$; Gain = 6dB; Right to Left)

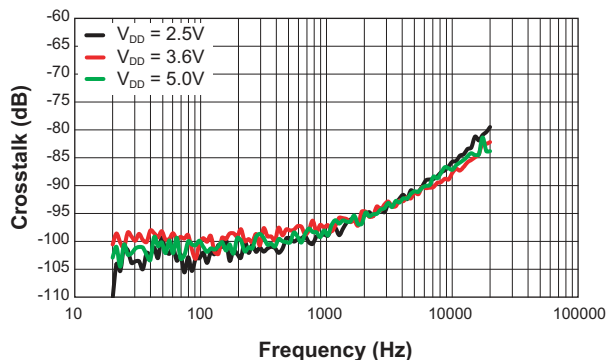

Shutdown Threshold Voltage vs. Temperature

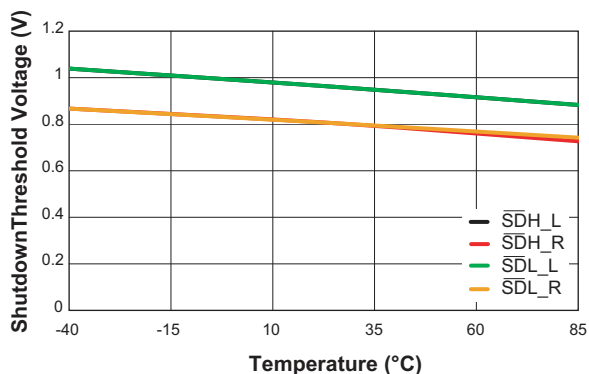

Shutdown Threshold Voltage vs. Supply Voltage

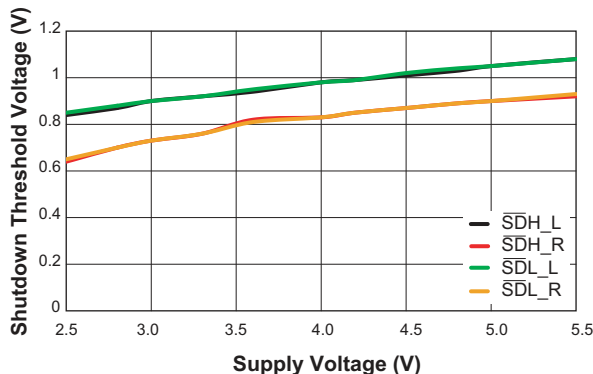

2.5W/Ch Stereo Class D Audio Power Amplifier

Functional Block Diagram

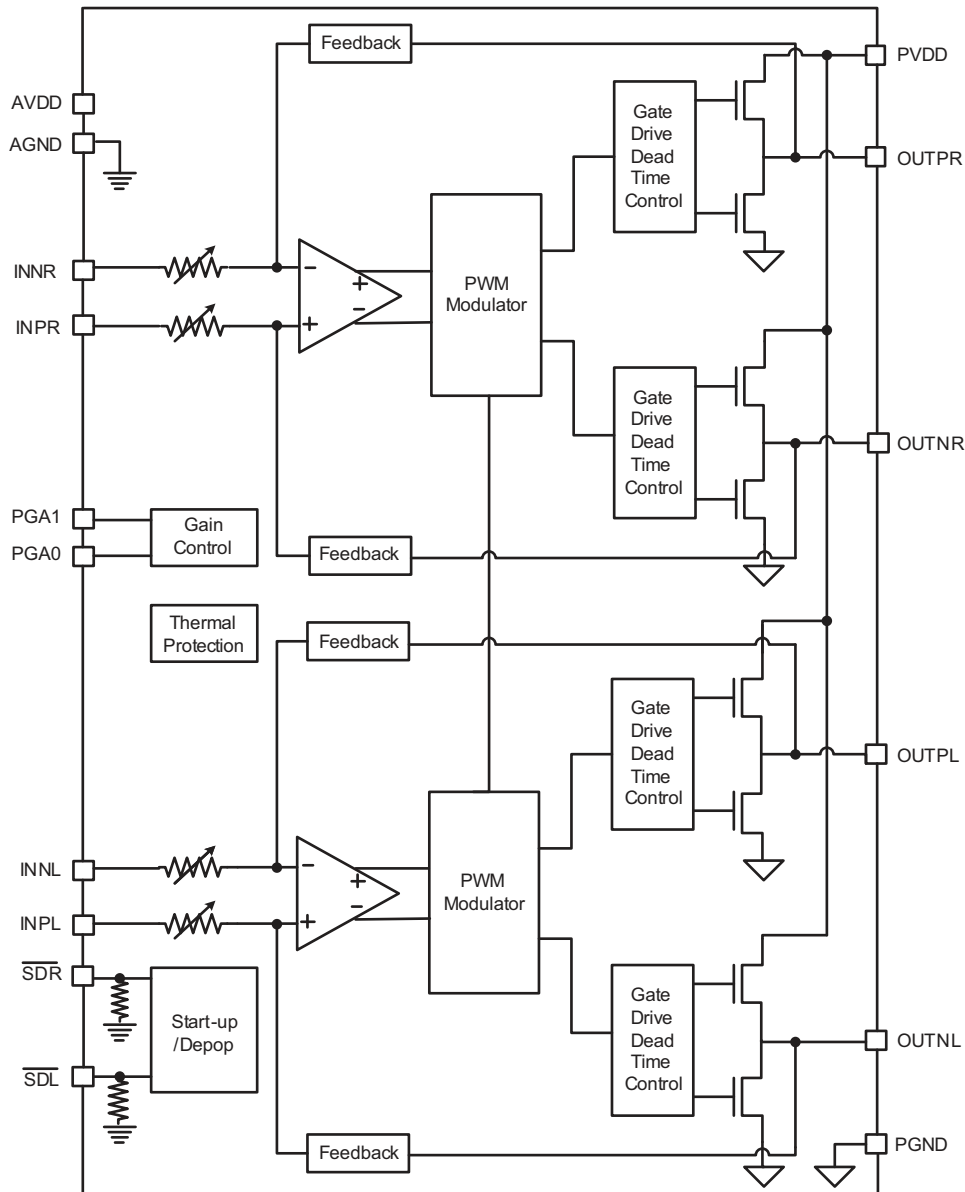

Application Information

The AAT5102 is a closed loop pulse-width-modulated switch mode power amplifier for driving bridge-tied load. It features high performance with high efficiency, high SNR and low THD+N. It also offers built-in over-temperature protection.

Gain Setting

The AAT5102 voltage gain can be programmed to 6, 12, 18 and 24dB via two inputs, PGA1 and PGA0. See Table 1 for gain setting.

2.5W/Ch Stereo Class D Audio Power Amplifier

PGA1	PGA0	Voltage Gain (dB)	Input Impedance (kΩ)
0	0	6	28
0	1	12	14
1	0	18	28
1	1	24	14

Table 1: Gain Setting.

Input High-Pass Filter

C_{IN} is the input DC blocking capacitor which forms input high pass filter with amplifier input impedance. The corner frequency is determined from the equation:

$$f_{-3dB} = \frac{1}{2 \cdot \pi \cdot R_I \cdot C_I}$$

Where:

f_{-3dB} is -3dB corner frequency

R_I is the input resistance

C_I is the input capacitance

The value of C_I is important for the bass performance of the amplifier. The capacitors should have a tolerance of $\pm 10\%$ or better.

Power Supply Bypassing

The AAT5102 is a high performance Class-D amplifier, adequate supply decoupling is necessary for overall better performance. A good low equivalent series resistance (ESR) decoupling capacitor of $4.7\mu F$ or larger is recommended.

Thermal Protection

The AAT5102 features unlatched over temperature protection. During operation when the device junction temperature exceeds $145^\circ C$ (typical), the device enters into shutdown state and outputs are disabled. Once device junction temperature is reduced by $15^\circ C$, the device leaves shutdown state and returns to normal operation automatically.

Shutdown Mode

When \overline{SDR} and \overline{SDL} are pulled down to low voltage, the device is in its maximum power saving mode. In shutdown mode, outputs are pulled in weak low state. The high logic level applied on \overline{SDR} and \overline{SDL} wakes up the device after turn-on time (T_{ON}). When independent shutdown control for each channel is necessary in the application, connecting the audio source ground to the device ground is highly recommended.

Output Filter

A ferrite bead should be used to reduce EMI emissions if EMI sensitive devices nearby in the system. The ferrite bead acts essentially as high impedance to a high frequency emissions but very low impedance to low frequency signal. Choose the ferrite bead with high impedance at the frequency range of interest.

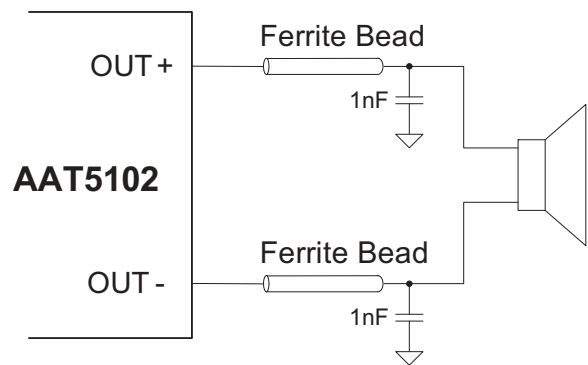

Figure 1: Typical Ferrite Bead Filter.

2.5W/Ch Stereo Class D Audio Power Amplifier

Manufacturer	Value (µF)	Voltage (V)	Case Size	Part Number
Murata	1	16	0603	GRM188R71C105KA12

Table 2: Recommended Input Capacitor Selection Information.

Manufacturer	Value (µF)	Voltage (V)	Case Size	Part Number
Murata	4.7	6.3	0603	GRM188R60J475KE19

Table 3: Recommended Decoupling Capacitor Selection Information

Manufacturer	Part Number	Impedance (Ω) (100MHz)	Rated Current (A) (Max)	DCR	Thickness (mm)	Case Size
TDK	MPZ1608S221A	220±25%	2	0.05	0.8	0603

Table 4: Recommended Output Ferrite Bead Selection Information.

Thermal Considerations and Maximum Output Power

The AAT5102 delivers a 5W power to 4Ω speaker. The limiting characteristic for the maximum output power is essentially package power dissipation and the device internal thermal limit.

At any given ambient temperature (T_A), the maximum package power dissipation can be determined by the following equation:

$$P_{D(MAX)} = \frac{T_{J(MAX)} - T_A}{\theta_{JA}}$$

The $T_{J(MAX)}$, the maximum junction temperature for the device is 125°C. The package thermal resistance θ_{JA} is 90.4°C/W for the WLCSP-16 package. For example, given $T_A=25^\circ\text{C}$, from above formula, the maximum power dissipation is 1.1W. With given efficiency η , the max output power can be determined by the following equation:

$$P_{O(MAX)} = \frac{P_{D(MAX)}}{1 - \eta}$$

AAT5102

2.5W/Ch Stereo Class D Audio Power Amplifier

Application Circuits

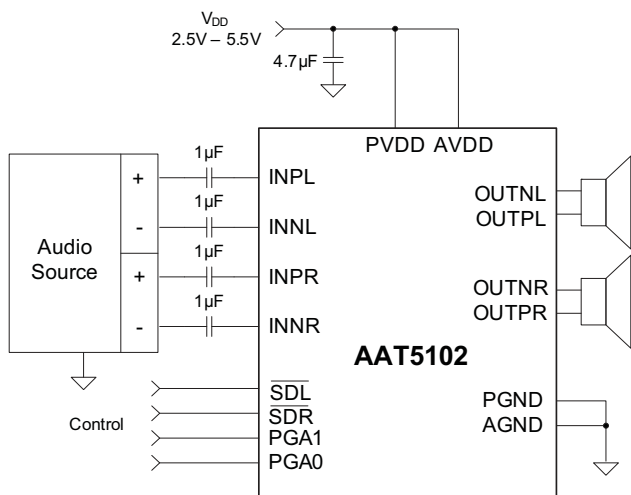

Figure 2: AAT5102 Application With Differential Input.

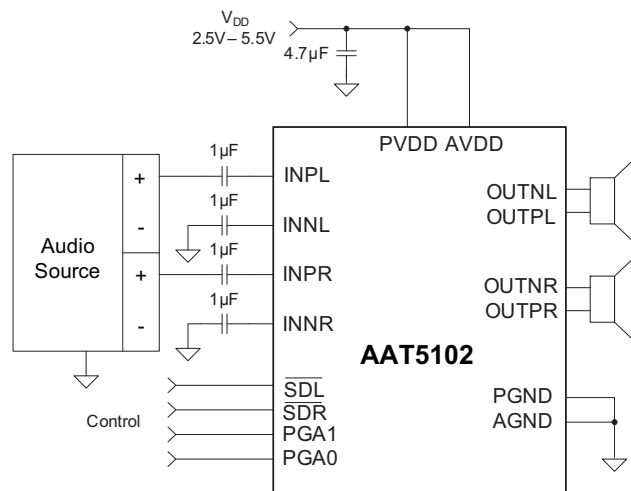

Figure 3: AAT5102 Application With Single-Ended Input.

Evaluation Board Schematic

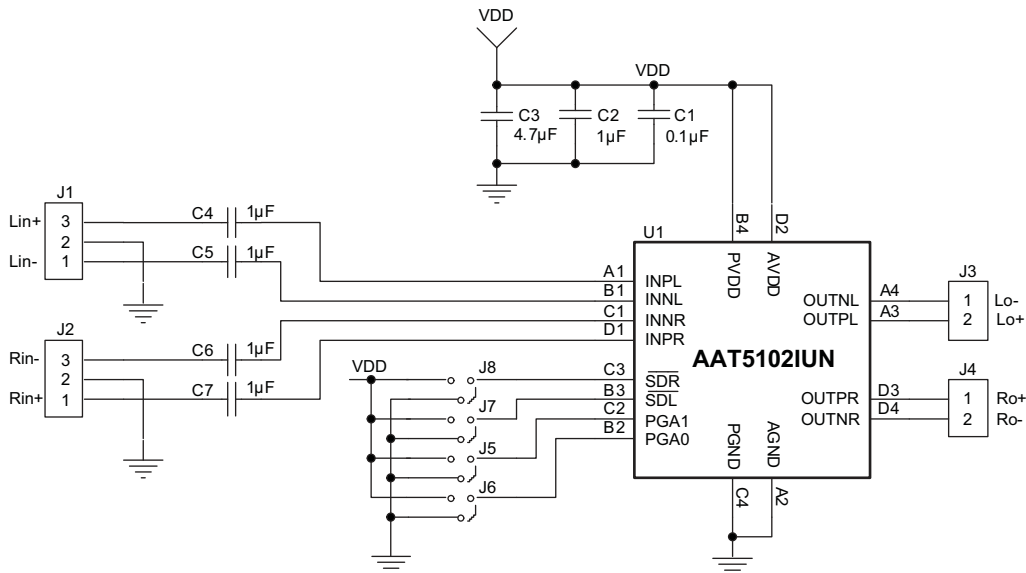

Figure 4: AAT5102IUN Evaluation Board Schematic.

DATA SHEET

AAT5102

2.5W/Ch Stereo Class D Audio Power Amplifier

Component	Part Number	Description	Manufacturer
U1	AAT5102IUN	Stereo Class D Audio Amplifier	Skyworks
C3	GRM188R60J475KE19	Cap Ceramic 4.7 μ F 0603 X7R 6.3V 10%	Murata
C2, C4, C5, C6, C7	GRM188R71C105KA12	Cap Ceramic 1 μ F 0603 X7R 16V 10%	Murata
C1	GRM188R71E104KA01	Cap Ceramic 0.1 μ F 0603 X7R 25V 10%	Murata

Table 5: AAT5102IUN Evaluation Board Bill of Materials.

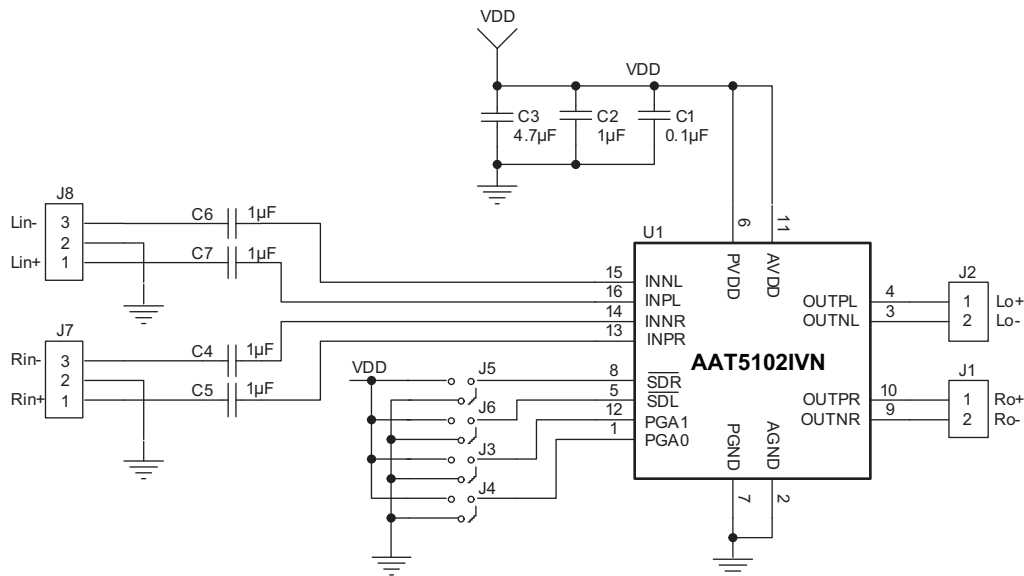
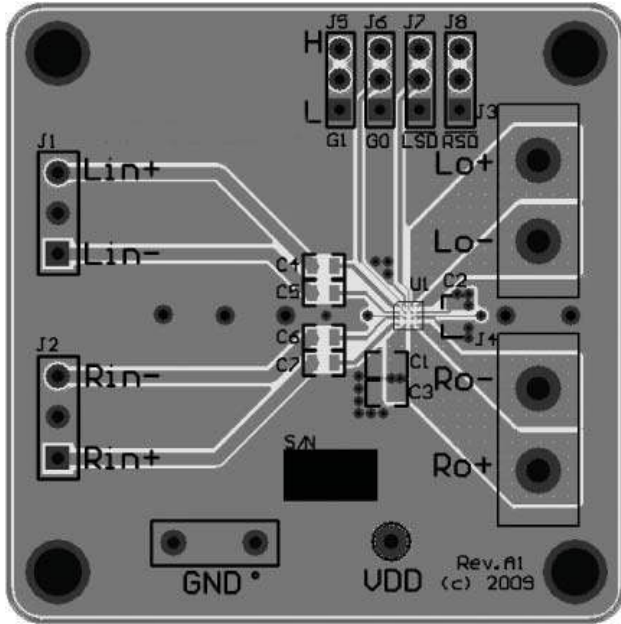

Figure 5: AAT5102IVN Evaluation Board Schematic.

Component	Part Number	Description	Manufacturer
U1	AAT5102IVN	Stereo Class D Audio Amplifier	Skyworks
C3	GRM188R60J475KE19	Cap Ceramic 4.7 μ F 0603 X7R 6.3V 10%	Murata
C2, C4, C5, C6, C7	GRM188R71C105KA12	Cap Ceramic 1 μ F 0603 X7R 16V 10%	Murata
C1	GRM188R71E104KA01	Cap Ceramic 0.1 μ F 0603 X7R 25V 10%	Murata

Table 6: AAT5102IVN Evaluation Board Bill of Materials.

Evaluation Board PCB Layout



a: Top Layer

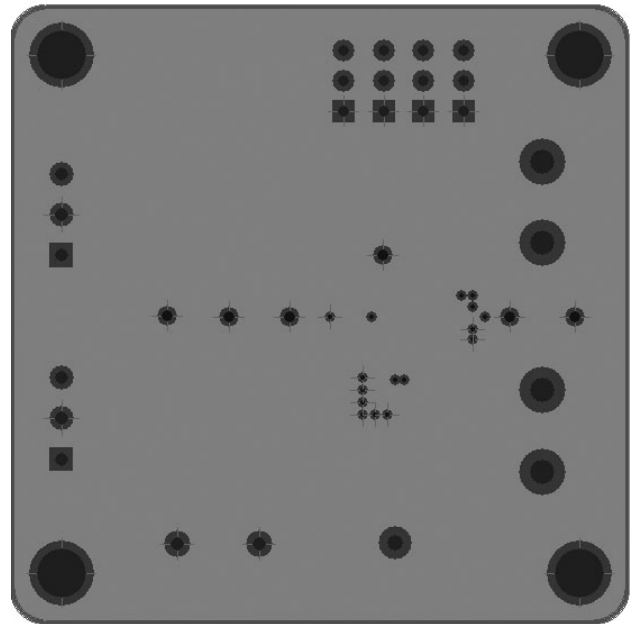

b: Ground Plane

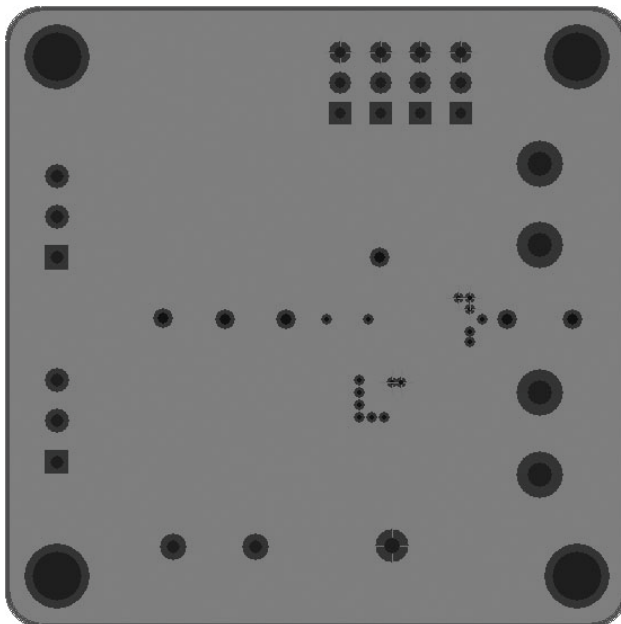

c: Power Plane

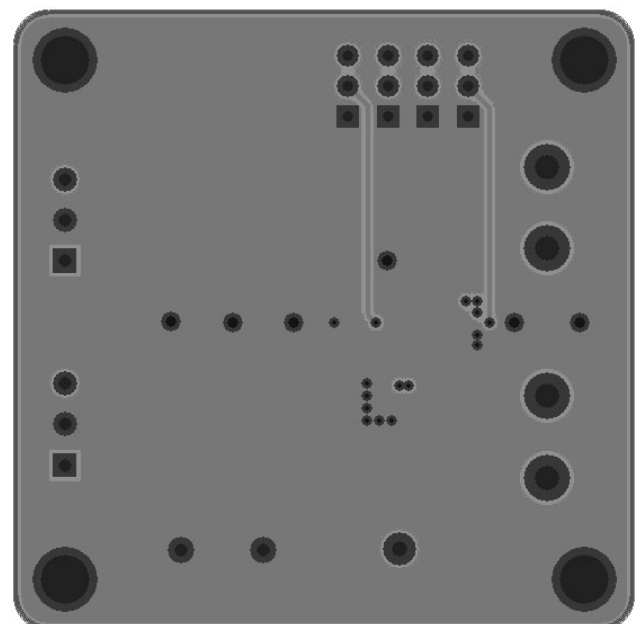

d: Bottom Layer

Figure 6: AAT5102IUN Evaluation Board PCB Layout.

2.5W/Ch Stereo Class D Audio Power Amplifier

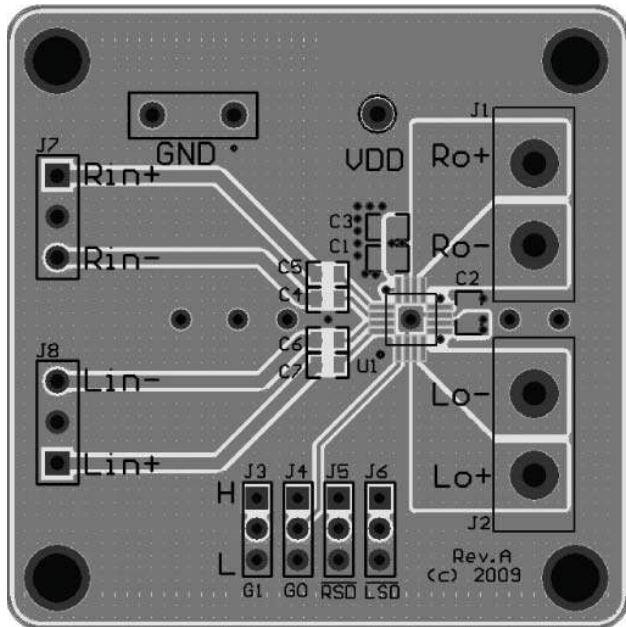

a: Top Layer

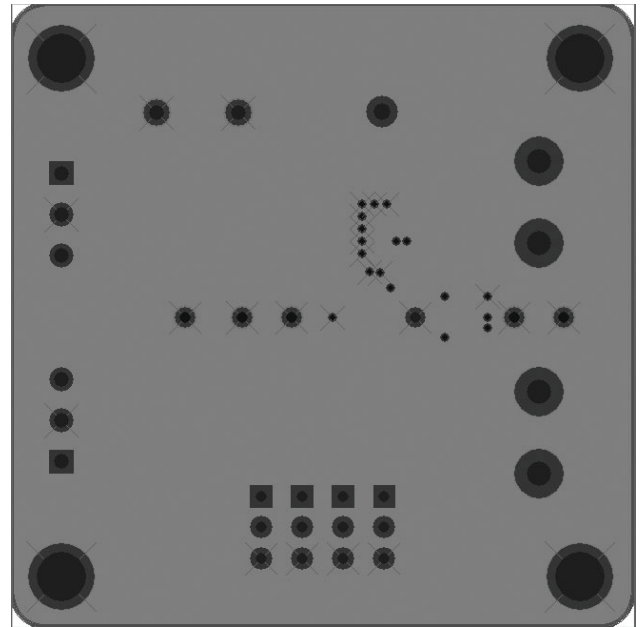

b: Ground Plane

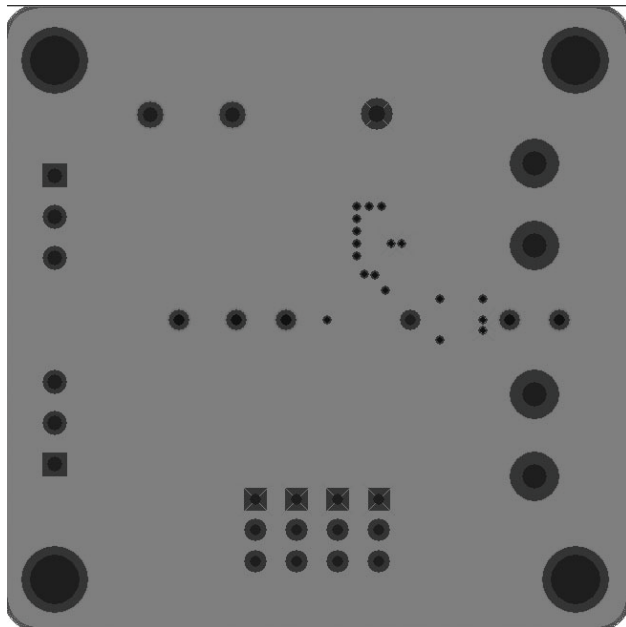

c: Power Plane

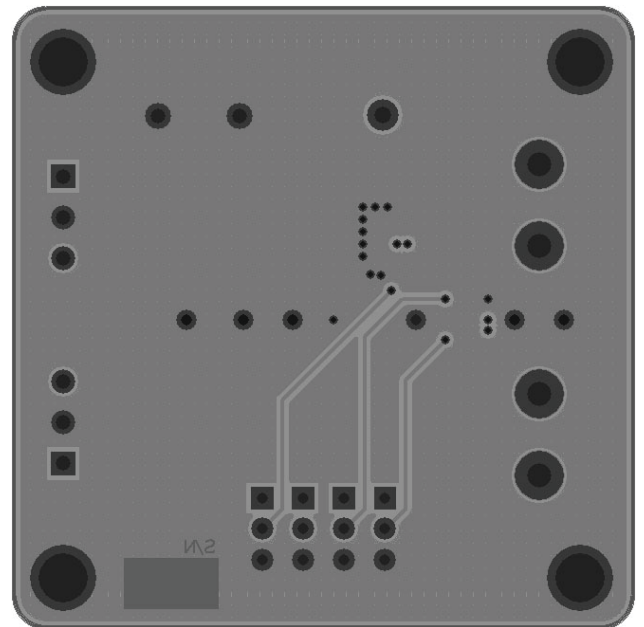

d: Bottom Layer

Figure 7: AAT5102IVN Evaluation Board PCB Layout

2.5W/Ch Stereo Class D Audio Power Amplifier

Ordering Information

Package	Marking ¹	Part Number (Tape and Reel) ²
WLCSP-16	9PYY	AAT5102IUN-T1
QFN33-16	C3XYY	AAT5102IVN-T1



Skyworks Green™ products are compliant with all applicable legislation and are halogen-free. For additional information, refer to *Skyworks Definition of Green™*, document number SQ04-0074.

Package Information

QFN33-16³

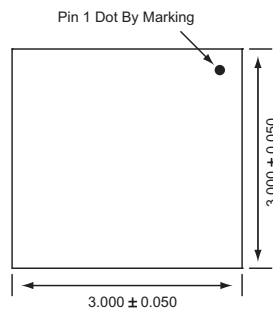

Top View

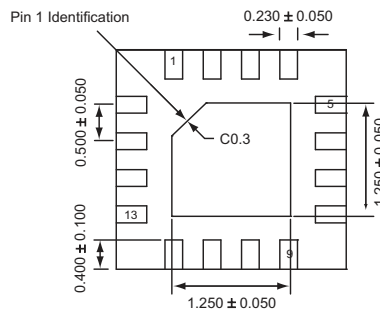

Bottom View

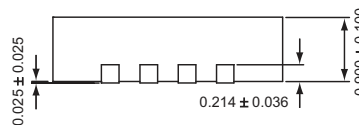

Side View

All dimensions in millimeters.

1. YY, XYY = assembly and date code.
 2. Sample stock is generally held on part numbers listed in **BOLD**.
 3. The leadless package family, which includes QFN, TQFN, DFN, TDFN and STDN, has exposed copper (unplated) at the end of the lead terminals due to the manufacturing process. A solder fillet at the exposed copper edge cannot be guaranteed and is not required to ensure a proper bottom solder connection.

DATA SHEET

AAT5102

2.5W/Ch Stereo Class D Audio Power Amplifier

WLCSP-16

Dimension Table (Unit: mm)

Symbol	Min	Nominal	Max
A	0.510	0.595	0.680
A1	0.120	0.145	0.170
A2	0.355	0.380	0.405
A3	0.035	0.070	0.105
D	1.610	1.645	1.680
E	1.610	1.645	1.680
D1	—	1.200	—
E1	—	1.200	—
SD	—	0.200	—
SE	—	0.200	—
e	0.400 BSC		
b	0.195	0.220	0.245
X	0.30	—	—
Y	0.30	—	—
X1	—	0.1	—
Y1	—	0.1	—
N	16 (Balls)		

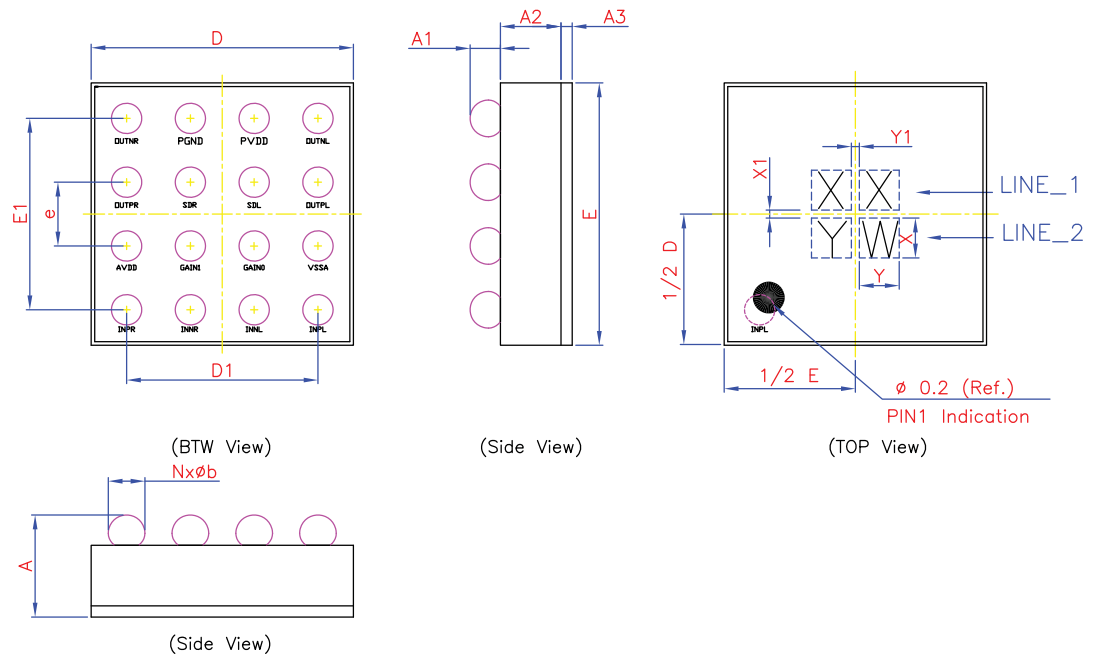

Copyright © 2012 Skyworks Solutions, Inc. All Rights Reserved.

Information in this document is provided in connection with Skyworks Solutions, Inc. ("Skyworks") products or services. These materials, including the information contained herein, are provided by Skyworks as a service to its customers and may be used for informational purposes only by the customer. Skyworks assumes no responsibility for errors or omissions in these materials or the information contained herein. Skyworks may change its documentation, products, services, specifications or product descriptions at any time, without notice. Skyworks makes no commitment to update the materials or information and shall have no responsibility whatsoever for conflicts, incompatibilities, or other difficulties arising from any future changes.

No license, whether express, implied, by estoppel or otherwise, is granted to any intellectual property rights by this document. Skyworks assumes no liability for any materials, products or information provided hereunder, including the sale, distribution, reproduction or use of Skyworks products, information or materials, except as may be provided in Skyworks Terms and Conditions of Sale.

THE MATERIALS, PRODUCTS AND INFORMATION ARE PROVIDED "AS IS" WITHOUT WARRANTY OF ANY KIND, WHETHER EXPRESS, IMPLIED, STATUTORY, OR OTHERWISE, INCLUDING FITNESS FOR A PARTICULAR PURPOSE OR USE, MERCHANTABILITY, PERFORMANCE, QUALITY OR NON-INFRINGEMENT OF ANY INTELLECTUAL PROPERTY RIGHT; ALL SUCH WARRANTIES ARE HEREBY EXPRESSLY DISCLAIMED. SKYWORKS DOES NOT WARRANT THE ACCURACY OR COMPLETENESS OF THE INFORMATION, TEXT, GRAPHICS OR OTHER ITEMS CONTAINED WITHIN THESE MATERIALS. SKYWORKS SHALL NOT BE LIABLE FOR ANY DAMAGES, INCLUDING BUT NOT LIMITED TO ANY SPECIAL, INDIRECT, INCIDENTAL, STATUTORY, OR CONSEQUENTIAL DAMAGES, INCLUDING WITHOUT LIMITATION, LOST REVENUES OR LOST PROFITS THAT MAY RESULT FROM THE USE OF THE MATERIALS OR INFORMATION, WHETHER OR NOT THE RECIPIENT OF MATERIALS HAS BEEN ADVISED OF THE POSSIBILITY OF SUCH DAMAGE.

Skyworks products are not intended for use in medical, lifesaving or life-sustaining applications, or other equipment in which the failure of the Skyworks products could lead to personal injury, death, physical or environmental damage. Skyworks customers using or selling Skyworks products for use in such applications do so at their own risk and agree to fully indemnify Skyworks for any damages resulting from such improper use or sale.

Customers are responsible for their products and applications using Skyworks products, which may deviate from published specifications as a result of design defects, errors, or operation of products outside of published parameters or design specifications. Customers should include design and operating safeguards to minimize these and other risks. Skyworks assumes no liability for applications assistance, customer product design, or damage to any equipment resulting from the use of Skyworks products outside of stated published specifications or parameters.

Skyworks, the Skyworks symbol, and "Breakthrough Simplicity" are trademarks or registered trademarks of Skyworks Solutions, Inc., in the United States and other countries. Third-party brands and names are for identification purposes only, and are the property of their respective owners. Additional information, including relevant terms and conditions, posted at www.skyworksinc.com, are incorporated by reference.