

5A, 18V, 650kHz, ACOT™ Synchronous Step-Down Converter

Purpose

The RT6207AH is a Advanced Constant On-Time (ACOT™) control architecture step-down converter with the input voltage range from 4.5V to 18V and provides 5A output current. This document explains the function and use of the RT6207AH evaluation board (EVB), and provides information to enable operation, modification of the evaluation board and circuit to suit individual requirements.

Table of Contents

Purpose.....	1
Introduction.....	2
Key Performance Summary Table.....	2
Bench Test Setup Conditions	3
Schematic, Bill of Materials & Board Layout	5
More Information.....	8
Important Notice for Richtek Evaluation Board	8

Introduction

General Product Information

The RT6207AH is a high-performance 650kHz, 5A stepdown regulator with internal power switches and synchronous rectifiers. It features quick transient response using its Advanced Constant On-Time (ACOT™) control architecture that provides stable operation with small ceramic output capacitors and without complicated external compensation, among other benefits. The input voltage range is from 4.5V to 18V and the output is adjustable from 0.7V to 8V. The proprietary ACOT™ control improves upon other fast response constant on-time architectures, achieving nearly constant switching frequency over line, load, and output voltage ranges. Since there is no internal clock, response to transients is nearly instantaneous and inductor current can ramp quickly to maintain output regulation without large bulk output capacitance. The RT6207AH is stable with and optimized for ceramic output capacitors. With internal 60mΩ switches and 22mΩ synchronous rectifiers, the RT6207AH displays excellent efficiency and good behavior across a range of applications, especially for low output voltages and low duty cycles. Cycle-by-cycle current limit provides protection against shorted outputs, input under-voltage lock-out, externally-adjustable soft-start, output under- and over-voltage protection, and thermal shutdown provide safe and smooth operation in all operating conditions. The RT6207AH is available in the UQFN-13JL 2x3 (FC) package, with exposed thermal pad.

Product Feature

- Fast Transient Response
- Advanced Constant On-Time (ACOT™) Control
- 4.5V to 18V Input Voltage Range
- Adjustable Output Voltage from 0.7V to 8V
- 5A Output Current
- 60mΩ Internal High-Side N-MOSFET and 22mΩ Internal Low-Side N-MOSFET
- Steady 650kHz Switching Frequency
- Up to 95% Efficiency
- Optimized for All Ceramic Capacitors
- Externally-Adjustable, Pre-Biased Compatible Soft-Start
- Cycle-by-Cycle Current Limit
- Input Under-Voltage Lockout
- Output Over- and Under-Voltage Protection
- Power Good Output
- Thermal Shutdown

Key Performance Summary Table

Key Features	Evaluation Board Number : PCB057_V1
Default Input Voltage	12V
Max Output Current	5A
Default Output Voltage	1.2V
Default Marking & Package Type	RT6207AHGQUF, UQFN-13JL 2x3 (FC)
Operation Frequency	Steady 650kHz at PWM

Bench Test Setup Conditions

Headers Description and Placement

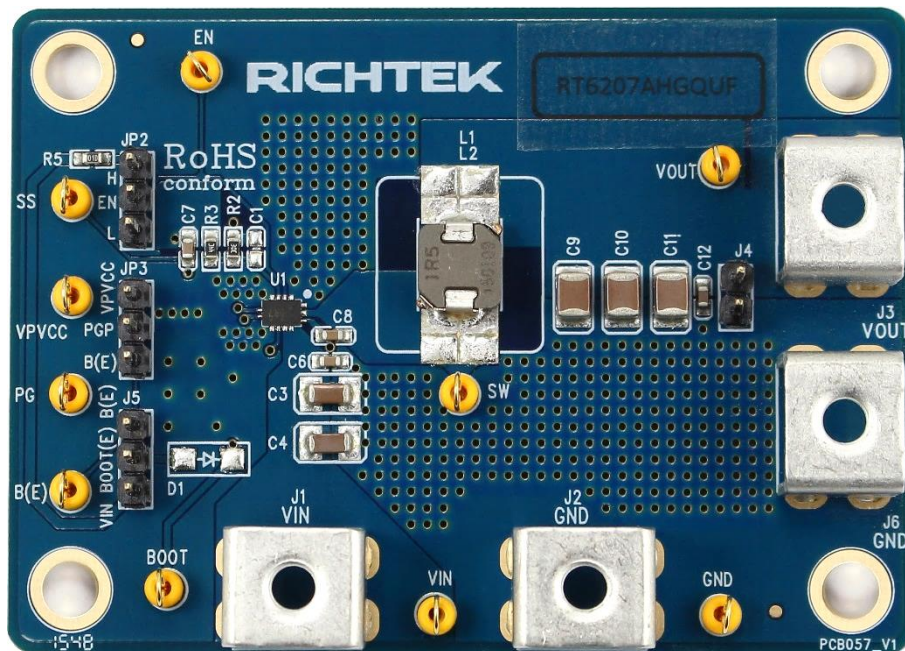

Please carefully inspect the EVB IC and external components, comparing them to the following Bill of Materials, to ensure that all components are installed and undamaged. If any components are missing or damaged during transportation, please contact the distributor or send e-mail to evb_service@richtek.com.

Test Points

The EVB is provided with the test points and pin names listed in the table below.

Test point/ Pin name	Signal	Comment (expected waveforms or voltage levels on test points)
VIN	Input voltage	Power Input and Connected to High-Side MOSFET Drain.
EN	Enable test point	High = Enable. Enable Control Input.
GND	Ground	Ground.
FB	Converter Feedback Input	Connect to output voltage feedback resistor divider.
NC	No Internal Connection	No Internal Connection.
SS	Soft-Start Control	A external capacitor should be connected to GND.
PVCC	Internal regulator output	5V Power Supply Output. A capacitor (typical 1 μ F) should be connected to GND.
PGOOD	Power good signal	Open Drain Power Good Output.
BOOT	Bootstrap supply test point	Bootstrap. This capacitor is needed to drive the power switch's gate above the supply voltage. It is connected between SW and BOOT pins to form a floating supply across the power switch driver. A 0.1 μ F capacitor is recommended for use.
SW	Switch node test point	Connect this pin to an external L-C filter.

Power-up & Measurement Procedure

1. Apply a 12V nominal input power supply ($4.5V < V_{IN} < 18V$) to the VIN and GND terminals.
2. Set the jumper at JP2 to connect terminals 2 and 3, connecting EN to VIN through resistor R5, to enable operation.
3. Verify the output voltage (approximately 1.2V) between VOUT and GND.
4. Connect an external load up to 5A to the VOUT and GND terminals and verify the output voltage and current.

Output Voltage Setting

Set the output voltage with the resistive divider (R2, R3) between VOUT and GND with the midpoint connected to FB. The output is set by the following formula :

$$V_{OUT} = V_{FB} \times \left(1 + \frac{R2}{R3} \right)$$

Schematic, Bill of Materials & Board Layout

EVB Schematic Diagram

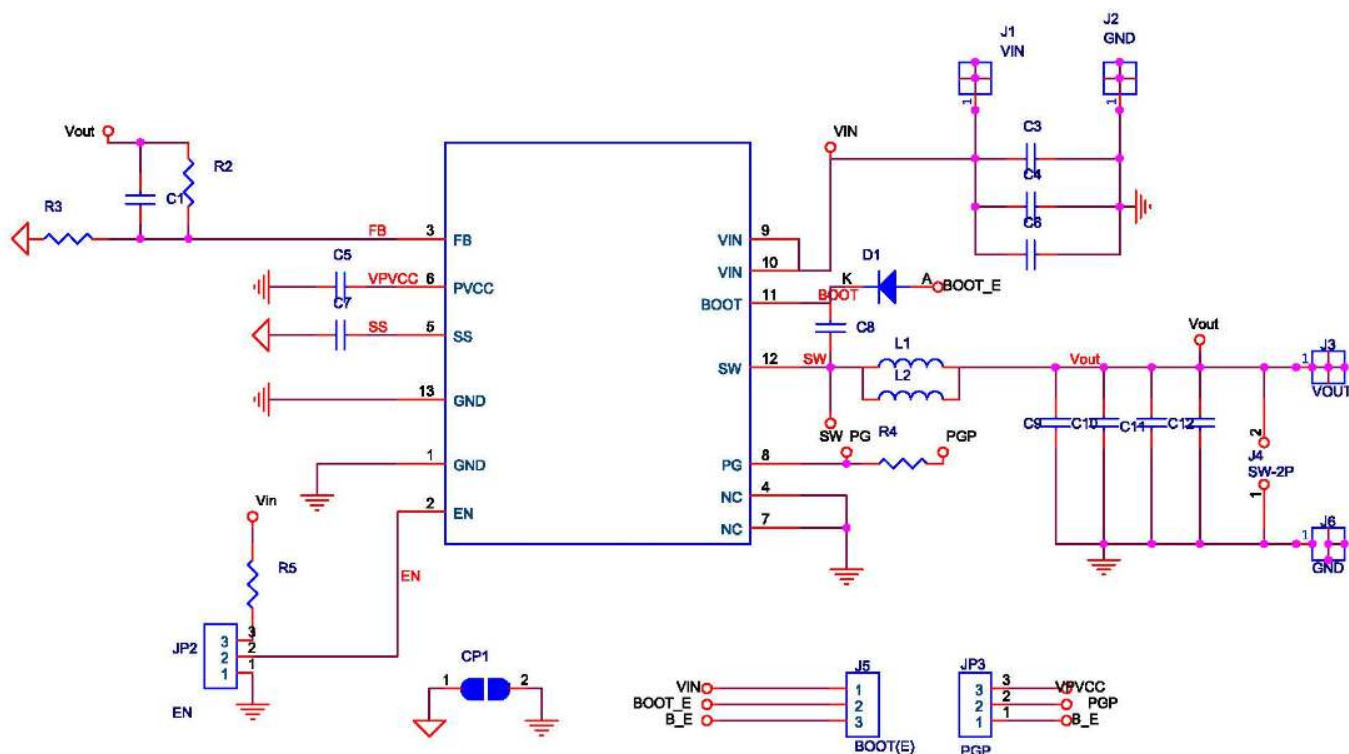

Bill of Materials

Reference	Qty	Part Number	Description	Package	Manufacture
C1, D1, L2	3		NC		
C3, C4	2	UMK325BJ106MM-T	10 μ F/50V/X5R	C-1210	TAIYO YUDEN
C5	1	C1608X5R1E105KT000E	1 μ F/25V/X5R	C-0603	TDK
C6, C8, C12	3	C1608X7R1E104KT000N	0.1 μ F/50V/X7R	C-0603	TDK
C7	1	C1608X7R1E104KT000N	3.9nF/50V/X7R	C-0603	TDK
C9, C10, C11	3	C3225X5R1E226MT	22 μ F/25V/X5R	C-1210	TDK
J1	1	VIN	Golden pin		
J2, J6	2	GND	Golden pin		
J3	1	VOUT	Golden pin		
L1	1	NRS8030T1R0NJGJ	1.0 μ H		TAIYO YUDEN
R2	1		17k	R-0603	
R3	1		24k	R-0603	
R4, R5	2		100k	R-0603	
CP1	1		short		
U1	1	RT6207AHGQUF	DC/DC Converter	UQFN-13JL 2x3 (FC)	RICHTEK

PCB Layout

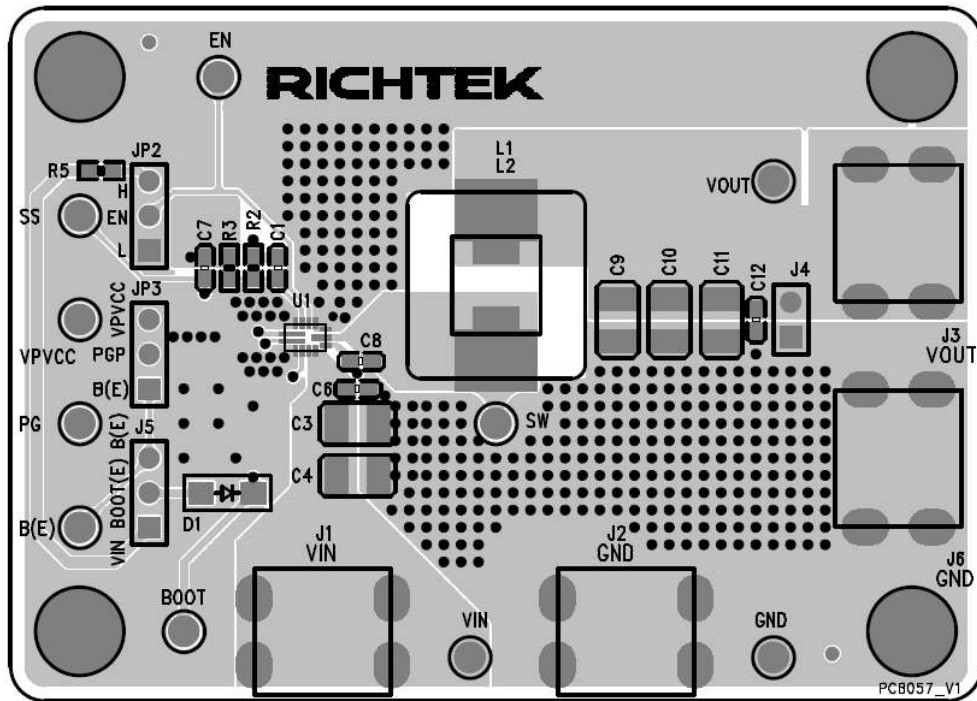

Top View (1st layer)

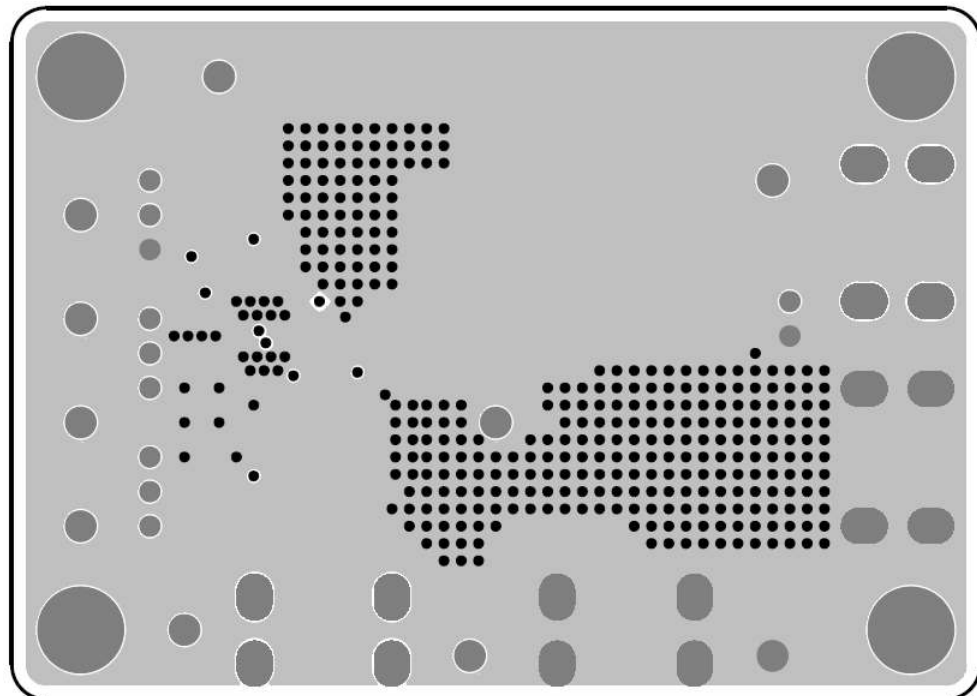

PCB Layout—Inner Side (2nd Layer)

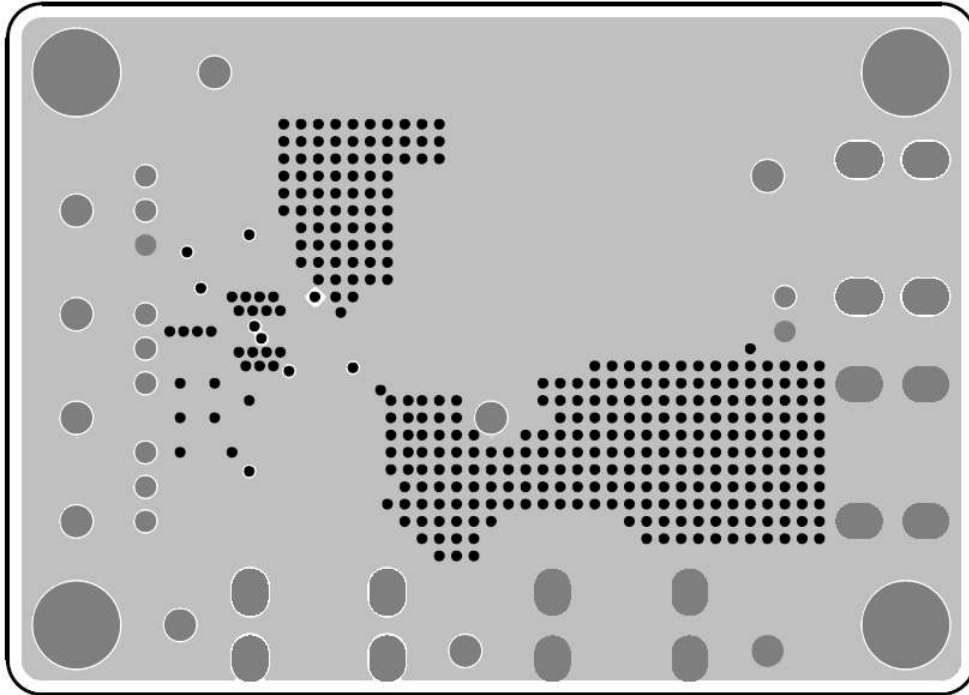

PCB Layout—Inner Side (3rd Layer)

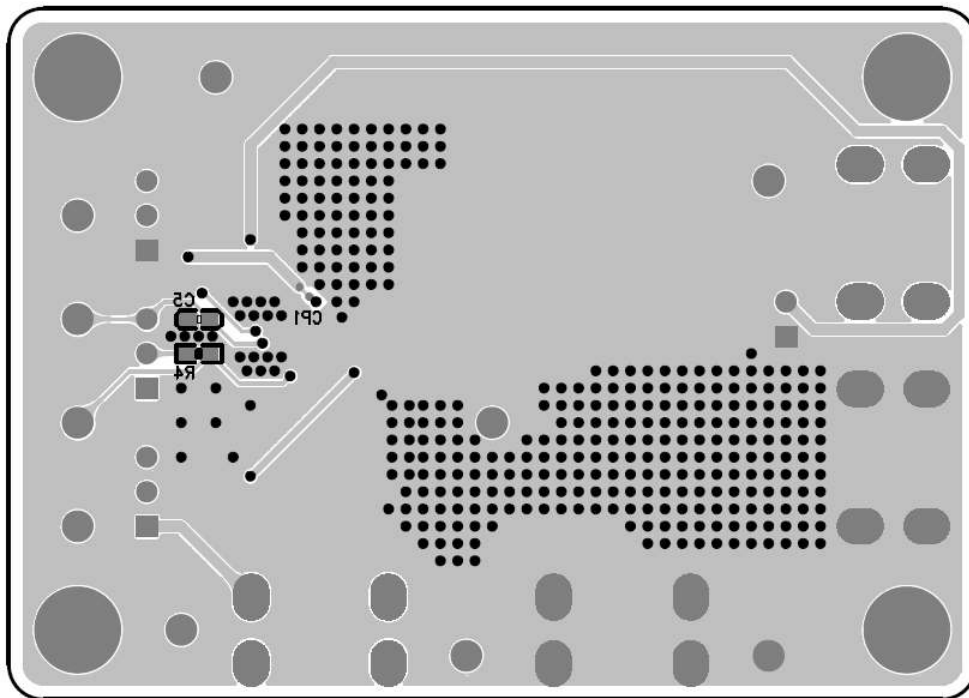

Bottom View (4th Layer)

More Information

For more information, please find the related datasheet or application notes from Richtek website <http://www.richtek.com>.

Important Notice for Richtek Evaluation Board

THIS DOCUMENT IS FOR REFERENCE ONLY, NOTHING CONTAINED IN THIS DOCUMENT SHALL BE CONSTRUED AS RICHTEK'S WARRANTY, EXPRESS OR IMPLIED, UNDER CONTRACT, TORT OR STATUTORY, WITH RESPECT TO THE PRESENTATION HEREIN. IN NO EVENT SHALL RICHTEK BE LIABLE TO BUYER OR USER FOR ANY AND ALL DAMAGES INCLUDING WITHOUT LIMITATION TO DIRECT, INDIRECT, SPECIAL, PUNITIVE OR CONSEQUENTIAL DAMAGES.