

SN70C11

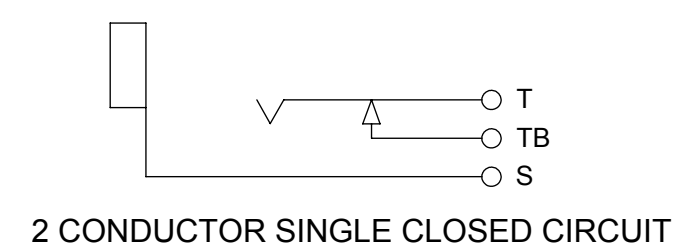

SN70C12A

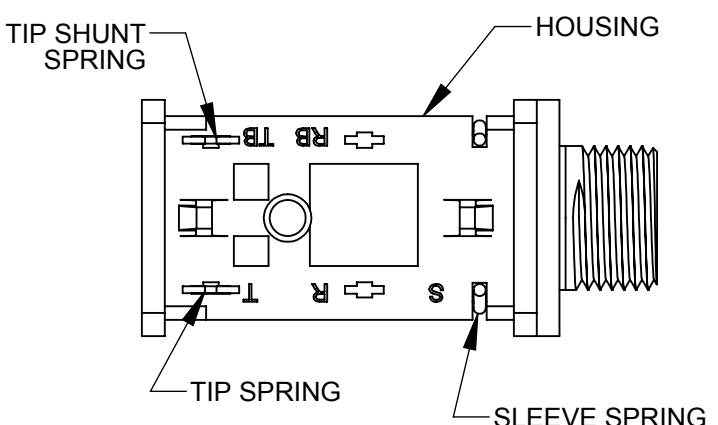
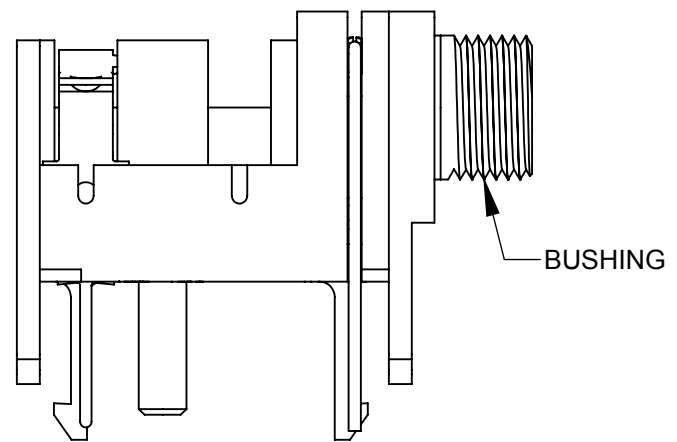
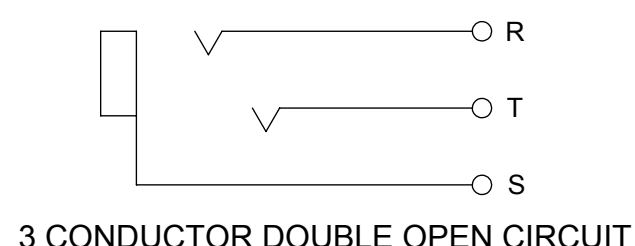
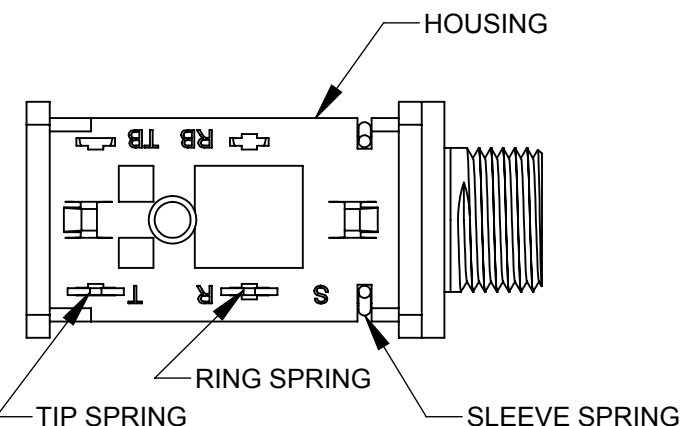
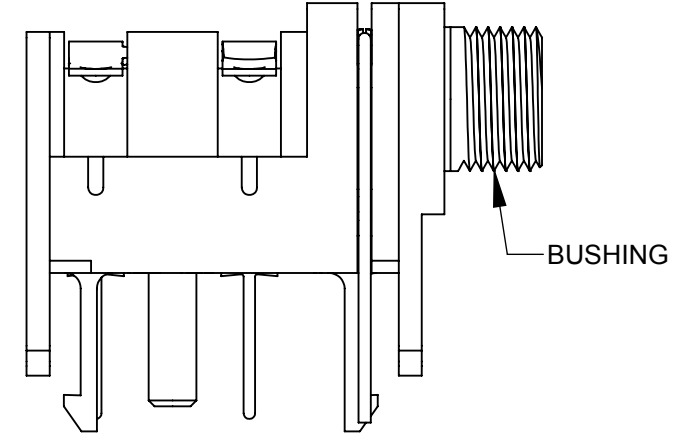

SN70C12B

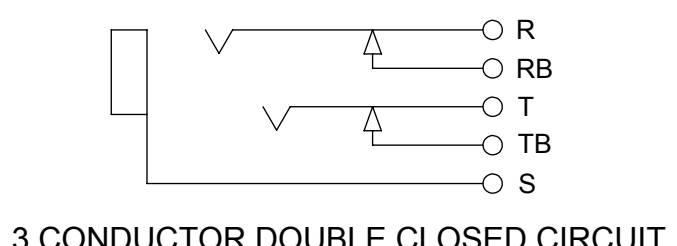
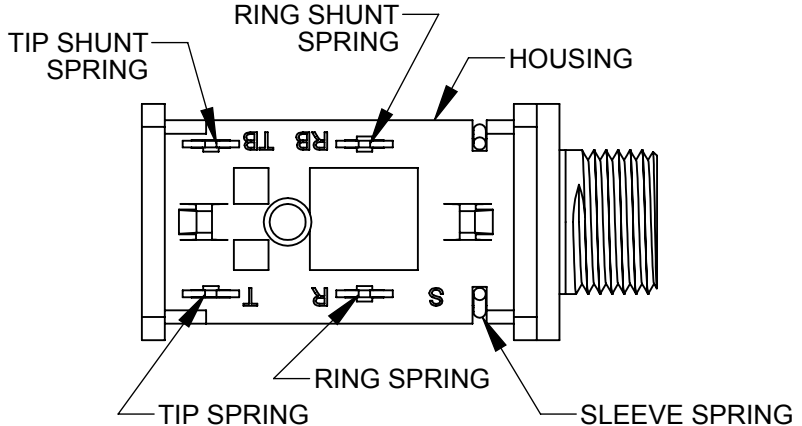
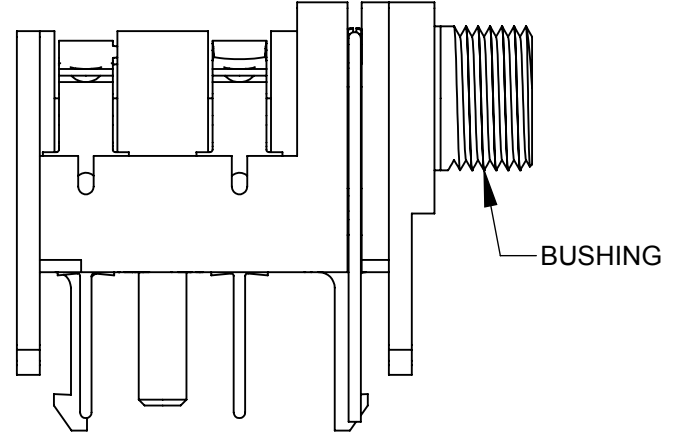

SN70C14B

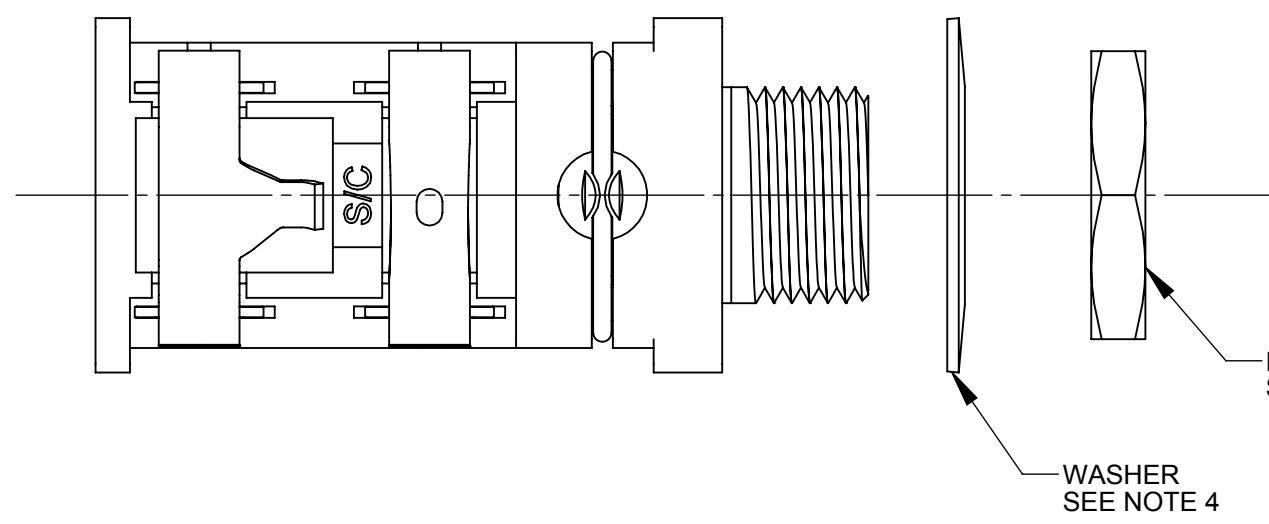

HEX NUT
SEE NOTE 4

WASHER
SEE NOTE 4

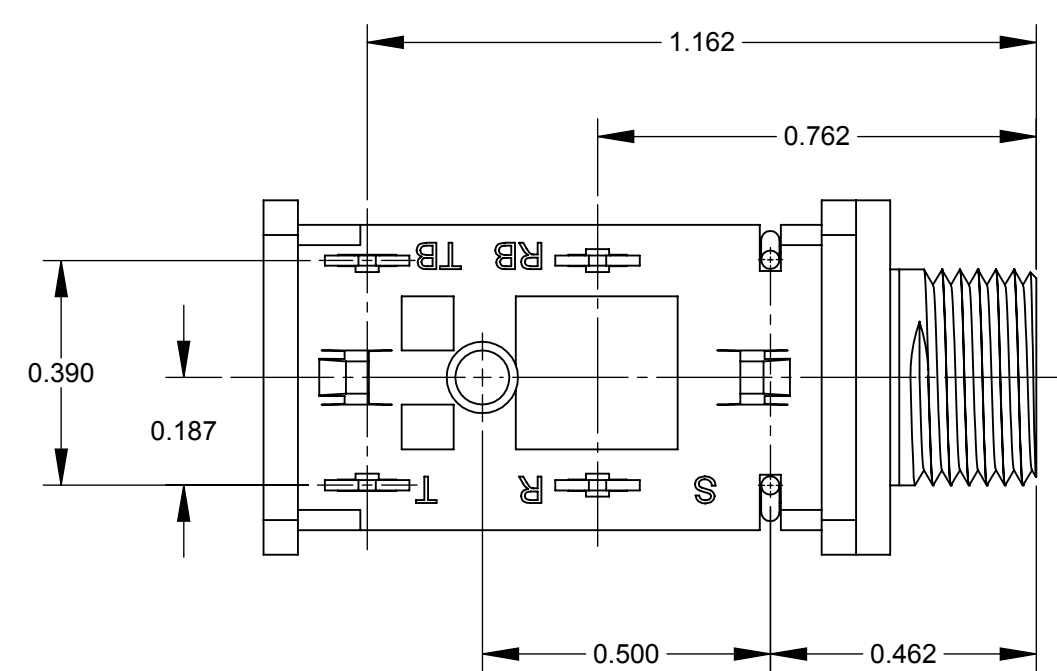
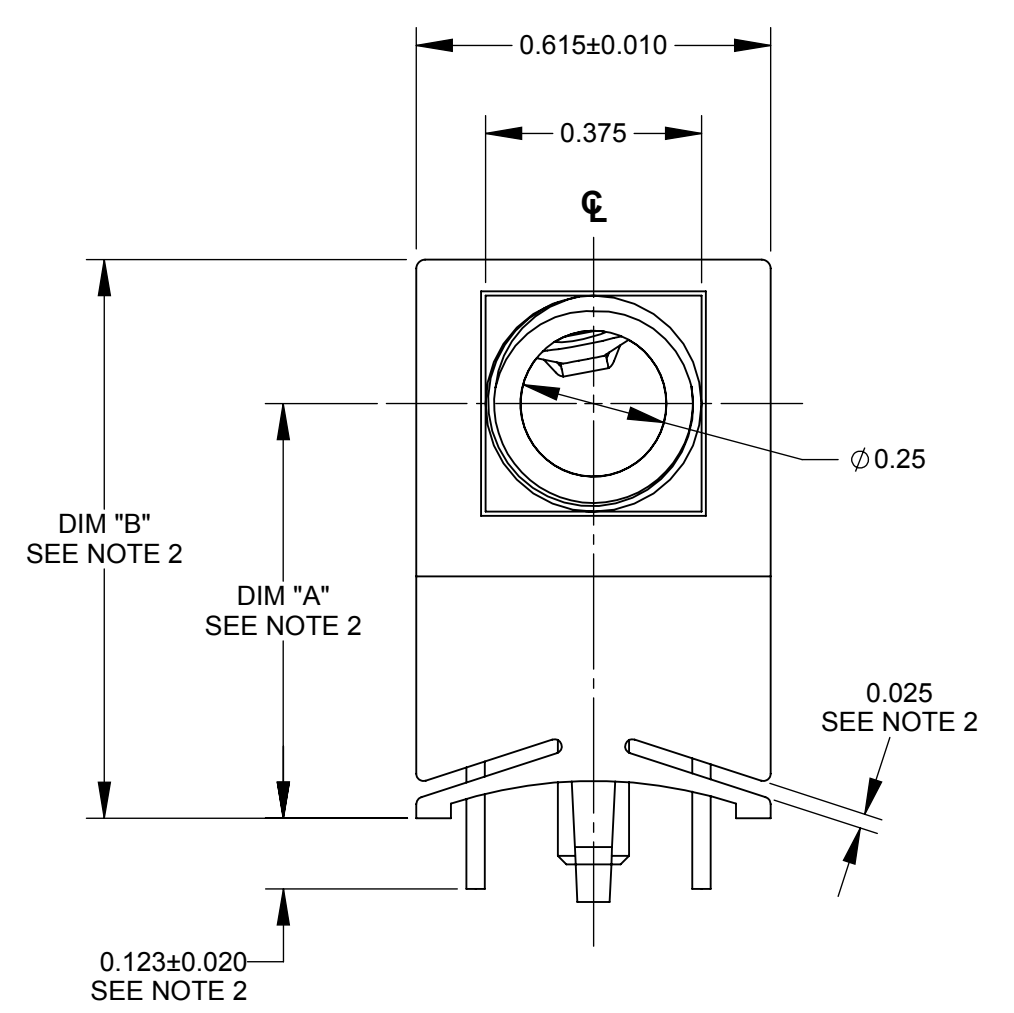
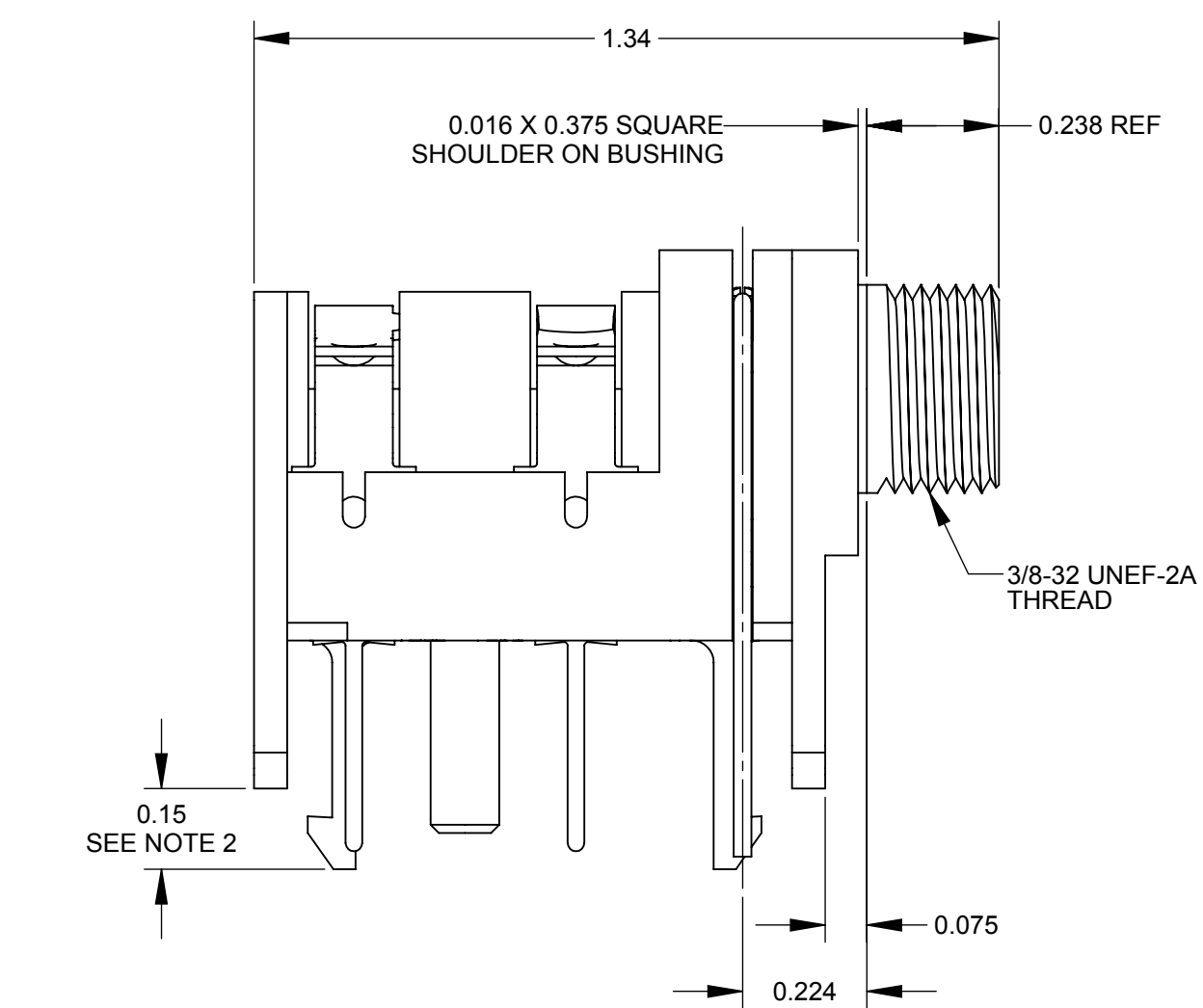
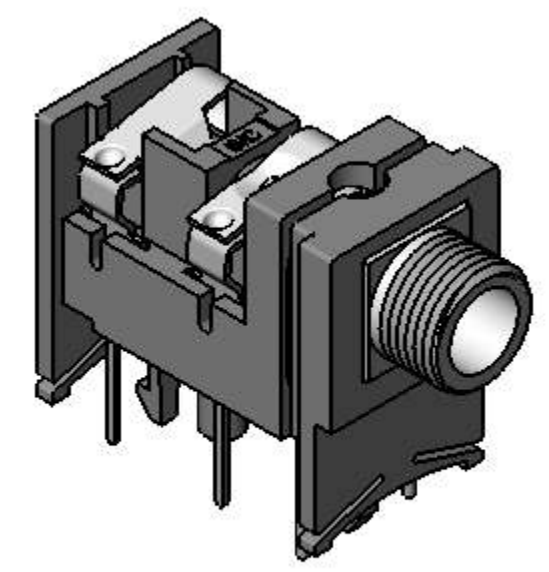

SN70C14B SHOWN

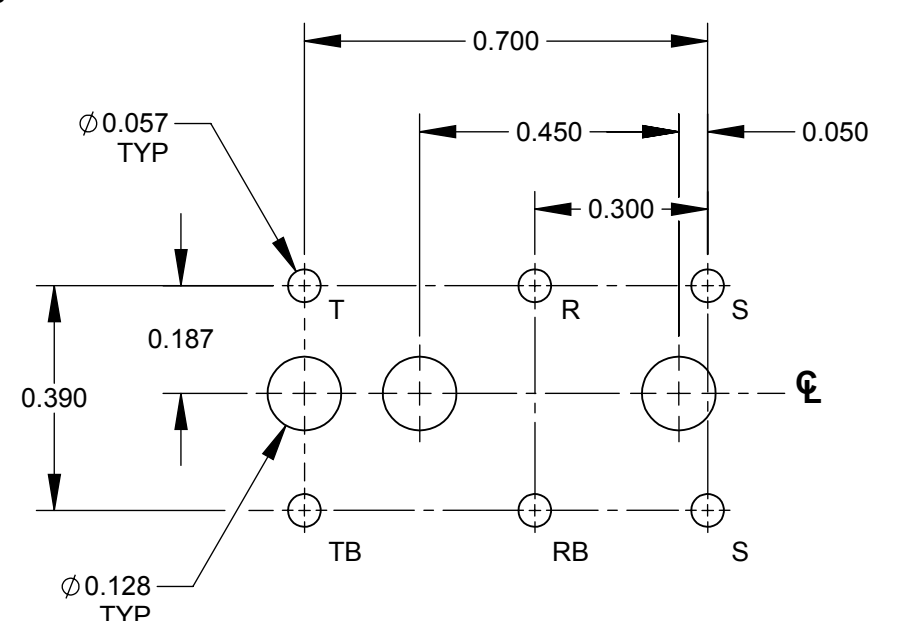

RECOMMENDED PC BOARD LAYOUT COMPONENT SIDE

- NOTES:
- MAY BE USED WITH PC BOARD THICKNESSES RANGING FROM 0.054 - 0.070.
 - THESE DIMENSIONS VARY DEPENDING ON PCB THICKNESS. DIMENSIONS SHOWN ARE FREE STATE AS SHIPPED.
 - MATERIAL SPECIFICATIONS:
HOUSING - THERMOPLASTIC, BLACK.
SPRINGS - SPECIAL COPPER ALLOY, TINNED.
BUSHING - COPPER ALLOY, NICKEL PLATED.
SLEEVE TERMINAL - SPECIAL COPPER ALLOY, TINNED.
HARDWARE - COPPER ALLOY, NICKEL PLATED.
 - HARDWARE SHIPPED UNASSEMBLED.
 - THESE PRODUCTS ARE RoHS COMPLIANT.

PART NUMBER	DIM "A"		DIM "B"	
	FREE STATE	WITH 0.062 THICK PCB	FREE STATE	WITH 0.062 THICK PCB
SN70C11	0.720	0.708	0.970	0.958
SN70C12A	0.720	0.708	0.970	0.958
SN70C12B	0.720	0.708	0.970	0.958
SN70C14B	0.720	0.708	0.970	0.958

REV	ECO NUMBER	DATE	BY	APVD
D	CAD REDRAW ECO #27409	11/17/14	PC	TJK

UNLESS OTHERWISE SPECIFIED

1. ALL DIMENSIONS IN INCHES

- TWO PLACE DECIMALS ±0.02

- THREE PLACE DECIMALS ±0.005

DO NOT SCALE DRAWING

THIS DRAWING DESCRIBES A DESIGN CONSIDERED PROPRIETARY IN NATURE, DEVELOPED AND MANUFACTURED BY SWITCHCRAFT INC. AND IS RELEASED ON A CONFIDENTIAL BASIS FOR IDENTIFICATION PURPOSES ONLY.

SIZE	WIDTH	MULT	LBS/M	TEMPER
FINISH		MATERIAL SPEC No.		
SPEC No.		SCALE 3:1		
DATE DRAWN	BY	CHKD	APVD	
11/21/83	EB	AM	RV	
		01/02/85	01/04/85	
NAME			PART No.	
PHONE JACK METAL BUSHING			SN70C SERIES	
				REV D

CUSTOMER DRAWING