

REVISIONS					
REV	ECO	DESCRIPTION	DATE	BY	APPR
A3	-	RELEASE NEW DWG FORMAT	21/OCT/13	DRP	-
A4	C1070S	UPDATE DRAWING	28/JUN/19	JOE	TOMMY
A5	C1298S	UPDATE PLATING	14/SEP/20	SULLEN	TOMMY

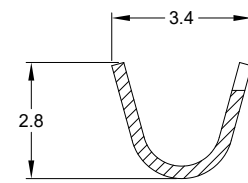

SECTION A-A
SCALE - 2:1

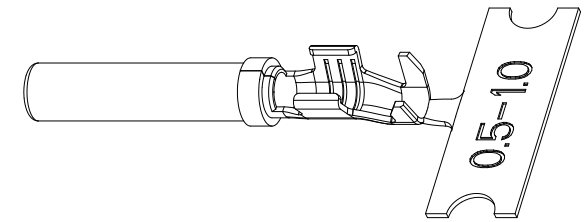
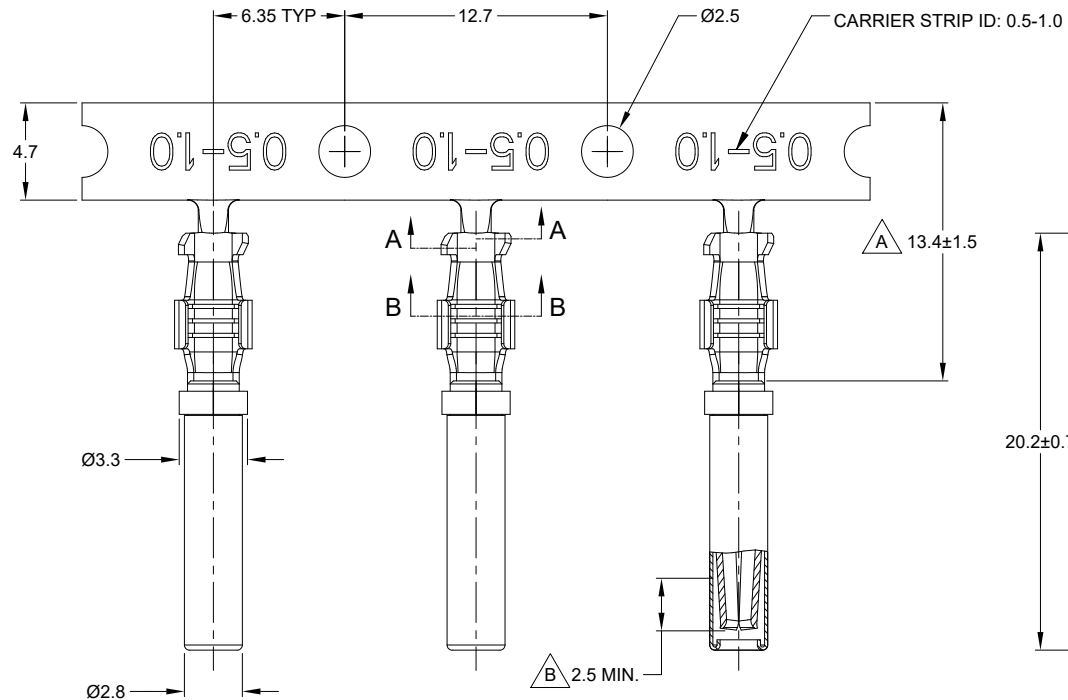
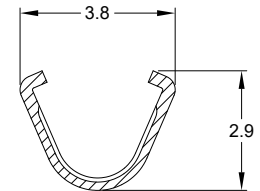

SECTION B-B
SCALE - 2:1

NOTES: UNLESS OTHERWISE SPECIFIED

- MATERIAL: COPPER ALLOY
- PLATING: SEE PART NUMBER CHART
- CONTACT SIZE: 16
- SPECIFICATIONS:
 - CURRENT RATING: 13 AMPS
 - CONTACT MILLIVOLT DROP: 100 MILLIVOLT DROP @ 13 AMP TEST CURRENT.
 - RoHS COMPLIANT
- RECOMMENDED WIRE RANGE: 18 - 20 AWG (0.75 - 0.5mm²)
RECOMMENDED INSUL O.D.: 1.40 - 2.54MM (0.055 - 0.1 INCH)
- PACKAGE: 4000 PCS/REEL
- AVAILABLE APPLICATORS: MFX-3950-K OR MFX-3950-G
- ALL DIMENSIONS ARE FOR REFERENCE USE ONLY

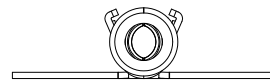

PART NUMBER CHART		
PLATING	PART NUMBER	PLATING DESCRIPTION
NICKEL	AT62-16-0622	SELECTIVE TIN OVER NICKEL OVERALL IN Δ ZONE
GOLD	AT62-16-0644	SELECTIVE GOLD FLASH OVER NICKEL OVERALL IN ∇ ZONE OR ENTIRE CONTACT
TIN	AT62-16-0677	TIN OVER NICKEL OVERALL

SEE PART NUMBER CHART		REF: 1062-16-0622, 1062-16-0644, 1062-16-0677		PART NUMBER		DESCRIPTION		ITEM
QUANTITY		SIGNATURES		DATE		MATERIALS LIST		
UNLESS OTHERWISE SPECIFIED		DRAWN: SULLENZANG		14/SEP/20		Amphenol Sine Systems - www.amphenol-sine.com 44724 Morley Drive Clinton Township, MI 48036 CONTACT, SOCKET, STAMPED, SIZE 16, 18-20 AWG, A SERIES		
1) All dimensions are in metric(mm).		CHECKED: ORIONLI		15/SEP/20				
2) Tolerances are as follows:		ENGINEER:						
1 PL DEC ±0.30		APPROVAL: TOMMYXIE		18/SEP/20				
2 PL DEC ±0.15		CUSTOMER:				THIS DRAWING IS SUPPLIED FOR INFORMATION ONLY. DESIGN FEATURES, SPECIFICATIONS AND PERFORMANCE DATA SHOWN HEREON ARE THE PROPERTY OF THE AMPHENOL CORPORATION. NO RIGHTS OF REPRODUCTION ARE IMPLIED. ALL DIMENSIONS ARE SUBJECT TO NORMAL MANUFACTURING VARIATIONS.		
3 PL DEC ±0.08		3) Note reference = Δ				SIZE: B C- TYPE: NONE DWG NO: AT62-16-06XX SCALE: NONE REVISION: A5		
MATERIAL SPECIFICATIONS:		PROCESS SPECIFICATIONS:		NEXT ASSY:		SHEET 1 OF 1		

TITLE: SOCKET, STAMPED, SIZE 16, 18-20 AWG, A SERIES
DWG NO: AT62-16-06XX
REV: A5
SH: 1
OF: 1