

Stepper motor driver evaluation board based on the L99SM81V for automotive applications



Features

- Board functionality based on [L99SM81V](#) programmable stepper motor driver for automotive applications:
 - with micro-stepping and hold functions
 - BEMF monitoring for stall detection
 - programmable configuration via SPI
 - 5 V internal linear voltage regulator (output available on board connector)
- Board reverse battery protection with [STD95N4F3](#) MOSFET, which can be substituted with two optionally mounted diodes and a jumper
- Input operating voltage range from 6 V to 28 V
- Output current up to 1.35 A
- Board size: 65 mm length x 81 mm width x 11 mm maximum component height
- WEEE and RoHS compliant
- All ST components are qualified Automotive grade
- Part of the AutoDevKit™ initiative
- Applications: automotive bipolar stepper motor



Description

The [AEK-MOT-SM81M1](#) evaluation board is designed to drive a bipolar stepper motor in micro-stepping mode, with coil voltage monitoring for stall detection.

This application board features the automotive-grade [L99SM81V](#) stepper motor driver with embedded power MOSFETs and a comprehensive set of I/Os for MCU control and feedback signaling using SPI communication through a 12-pin male connector or two 5-pin connectors on the board.

The board is developed as part of the AutoDevKit initiative, and evaluation firmware is available for suitable microcontrollers such as the automotive-grade SPC5 series MCU on the [AEK-MCU-C4MLIT1](#) control board.

Product summary	
AutoDevKit stepper motor driver board for automotive applications	AEK-MOT-SM81M1
programmable stepper motor driver for automotive applications	L99SM81V
Development environment	SPC5-Studio addon for Eclipse (with AutoDevKit plugin extension)
Suggested microcontroller	SPC5 family MCUs
Applications	Automotive bipolar stepper motor; e.g.: <ul style="list-style-type: none"> - adaptive vehicle front lighting systems - vehicle HUD projectors

1 Overview

The **AEK-MOT-SM81M1** board targets automotive applications such as adaptive front lighting systems and HUD projectors, with stepping resolution ranging from 4 full steps to 64 micro steps for the finest possible positional control.

The **L99SM81V** driver logically manages timers, counters, reference tables and mode or status registers that are read or set by the external microcontroller to drive the two coil phases of a bipolar stepper motor, with separate RUN and HOLD profiles for moving the rotor or keeping it stationary.

Apart from supply voltage and driver current diagnostics, the driver also monitors the output voltages across the phase terminals in order to detect and flag critical motor stall events that can compromise motor operation and control.

Figure 1. Car stepper motor application diagram

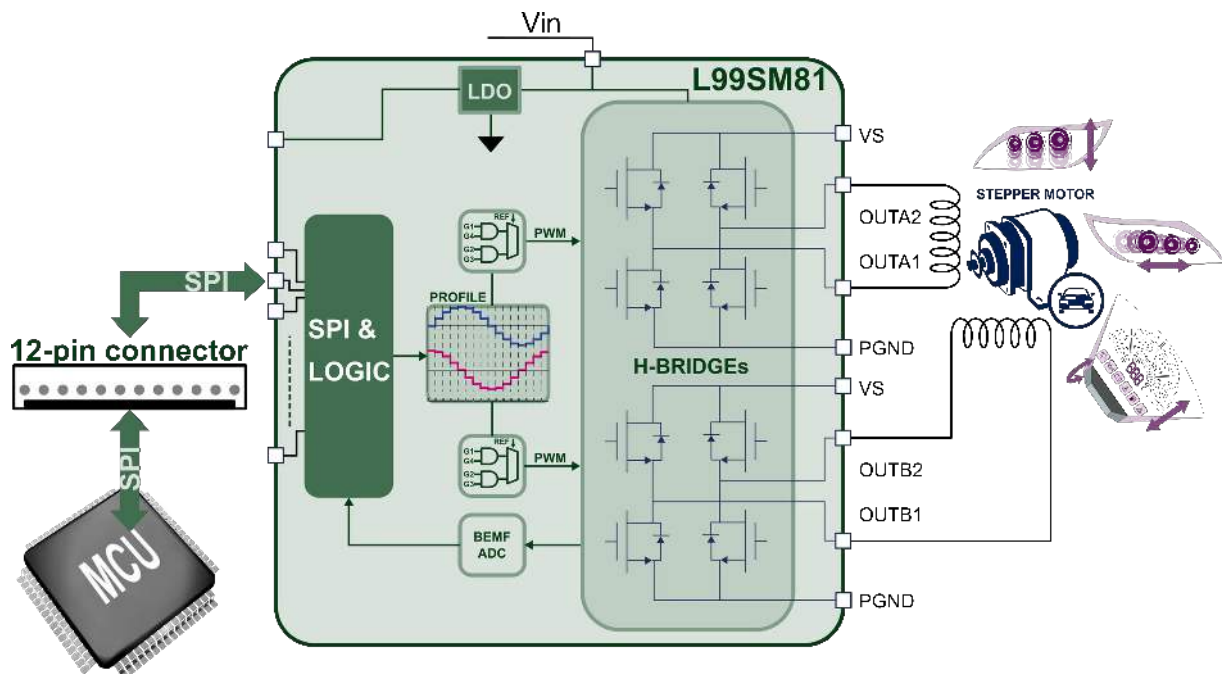

RELATED LINKS

Visit the [Automotive Bipolar Stepper Motor](#) page on the ST website for further relevant application and design information
[AutoDevKit: Adaptive Front Lighting demonstration kit video on YouTube](#)

2 Schematic diagrams

Figure 2. AEK-MOT-SM81M1 schematic diagram

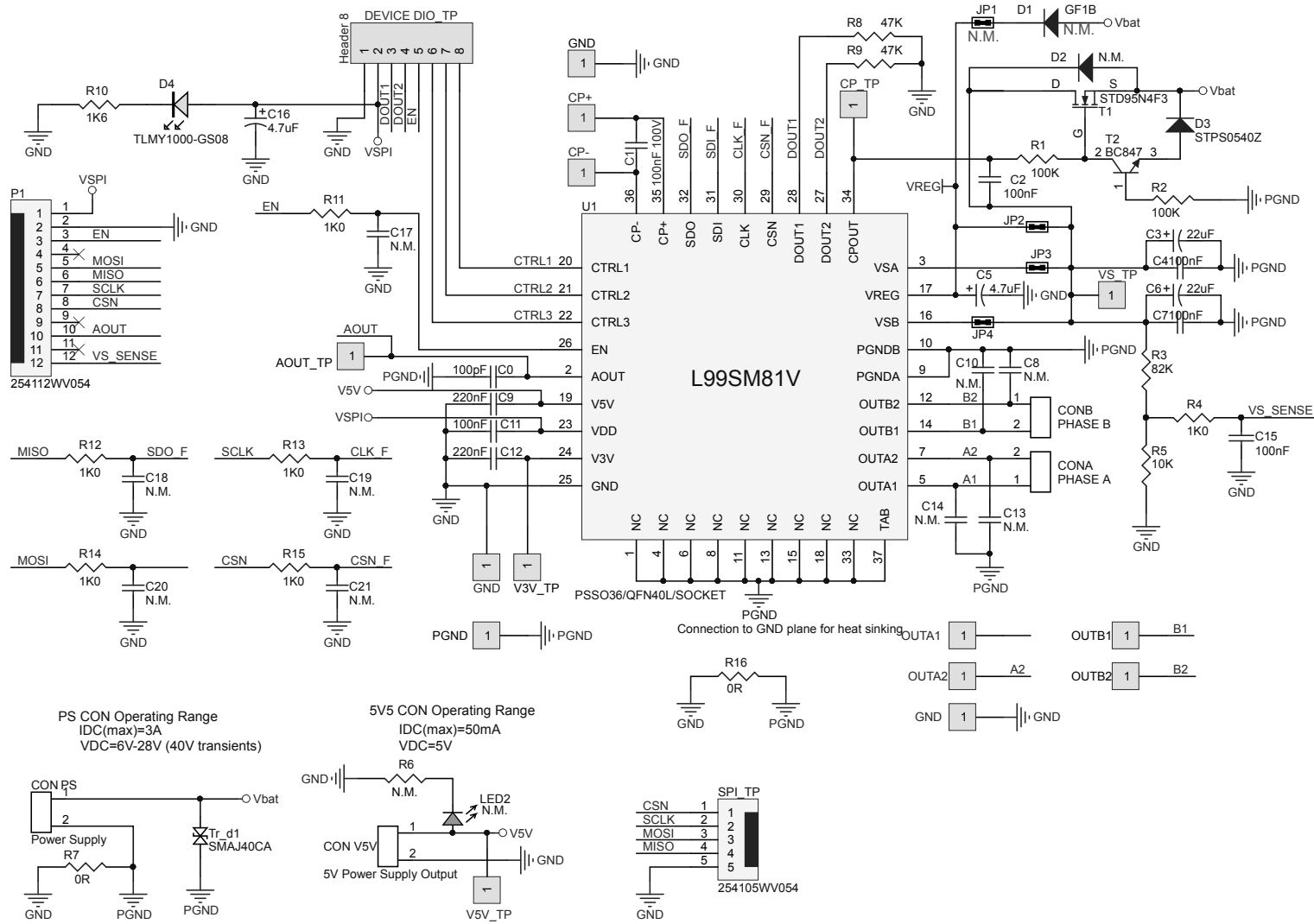

Revision history

Table 1. Document revision history

Date	Version	Changes
08-Jul-2019	1	Initial release.

IMPORTANT NOTICE – PLEASE READ CAREFULLY

STMicroelectronics NV and its subsidiaries (“ST”) reserve the right to make changes, corrections, enhancements, modifications, and improvements to ST products and/or to this document at any time without notice. Purchasers should obtain the latest relevant information on ST products before placing orders. ST products are sold pursuant to ST’s terms and conditions of sale in place at the time of order acknowledgement.

Purchasers are solely responsible for the choice, selection, and use of ST products and ST assumes no liability for application assistance or the design of Purchasers’ products.

No license, express or implied, to any intellectual property right is granted by ST herein.

Resale of ST products with provisions different from the information set forth herein shall void any warranty granted by ST for such product.

ST and the ST logo are trademarks of ST. For additional information about ST trademarks, please refer to www.st.com/trademarks. All other product or service names are the property of their respective owners.

Information in this document supersedes and replaces information previously supplied in any prior versions of this document.

© 2019 STMicroelectronics – All rights reserved