

MATERIALS AND FINISHES

BODY, OUTER CONTACT: BRASS  
PLATED SEE TABLE

CONTACT: PHOSPHOR BRONZE  
PLATED SEE TABLE

INSULATOR: TEFLON

O\_RING: SILICON RUBBER

DUST CAP: PE  
COLOR: TRANSPARENT

PERFORMANCE REQUIREMENTS:

FREQUENCY RANGE: DC-7000MHZ  
IMPEDANCE: 50 OHMS  
WITHSTANDING VOLTAGE: 1000V/50Hz  
VSWR: ≤1.30 @0-7000MHZ

PACKING BY TRAY

RG402 CABLE  
RECOMMENDED STRIPPING DIMENSIONS

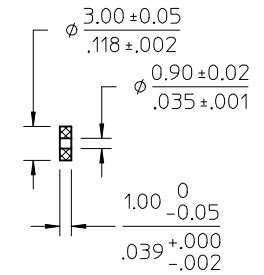
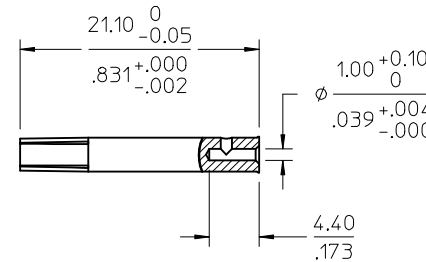
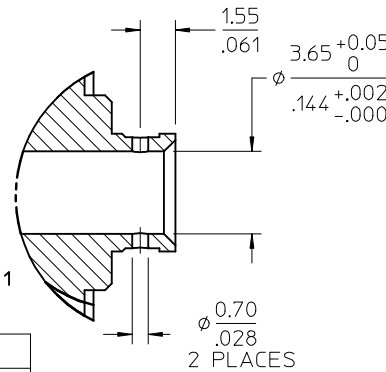
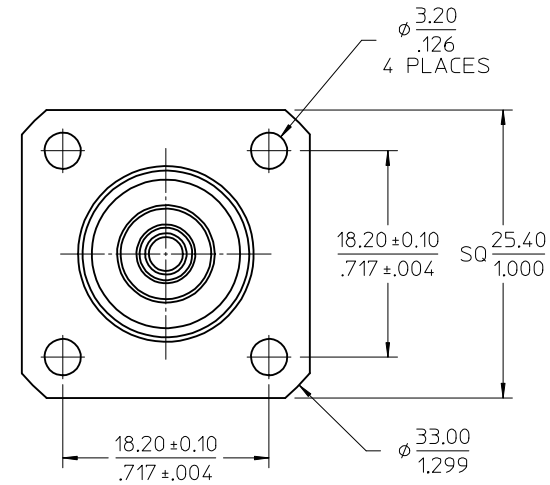
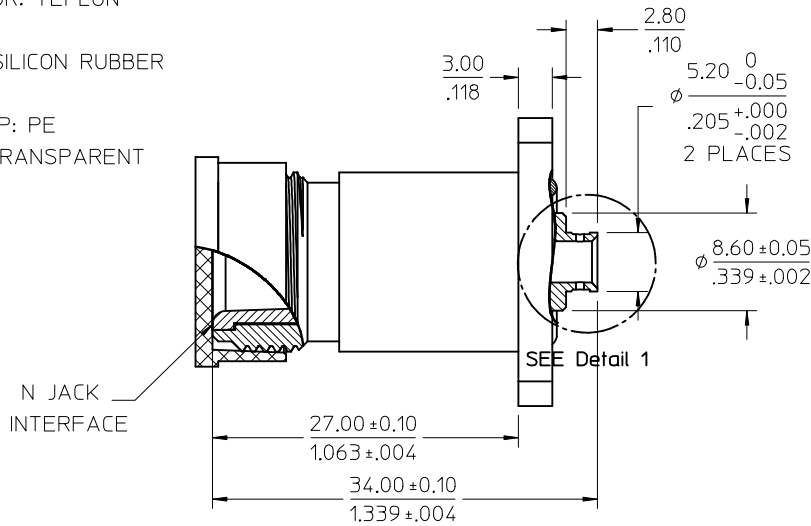
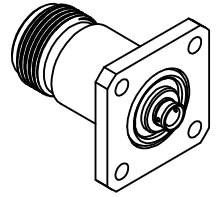
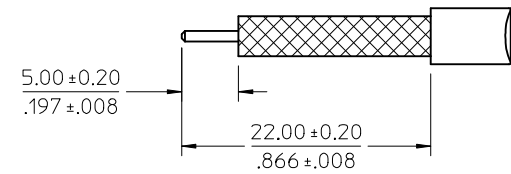

PART # 73141-4220

IEC60169-16	INTERFACE
SPECIFICATION	DESCRIPTION

CHG: NEW RELEASE PER PDRJ1507704 EC NO: URF2016-0093 DRWNL: CHEN03 2015/08/07 CHKD: MXU11 2015/08/07 APPR: MYE08 2015/08/07	REV	DESCRIPTION
	A	

QUALITY SYMBOLS	▽=0 ▽=0
-----------------	------------

GENERAL TOLERANCES (UNLESS SPECIFIED)	mm INCH
4 PLACES ±	±
3 PLACES ±	±
2 PLACES ±	±
1 PLACE ±	±
ANGULAR ± 2 °	
DRAFT WHERE APPLICABLE MUST REMAIN WITHIN DIMENSIONS	

DIMENSION STYLE	MM/IN
DRAWN BY	LCHEN03
DATE	2015/08/07
CHECKED BY	MXU11
DATE	2015/08/07
APPROVED BY	MYE08
DATE	2015/08/07
MATERIAL NO.	SEE TABLE

SCALE	DESIGN UNITS	THIRD ANGLE PROJECTION
	METRIC	
TITLE		
N JACK 4H FLANGE FOR 141 CABLE		
MOLEX INCORPORATED		
MATERIAL NO.	DOCUMENT NO.	SHEET NO.
SEE TABLE	SD-73141-422	1 OF 1
THIS DRAWING CONTAINS INFORMATION THAT IS PROPRIETARY TO MOLEX INCORPORATED AND SHOULD NOT BE USED WITHOUT WRITTEN PERMISSION		