

ASSEMBLY - VIEW FROM TOP

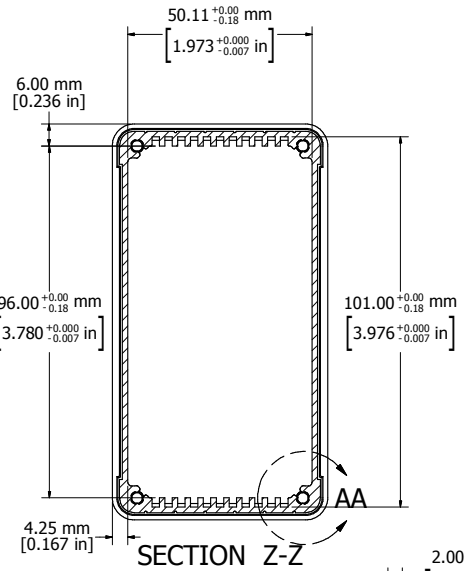

SECTION Z-Z

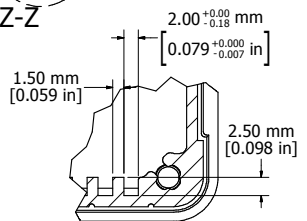
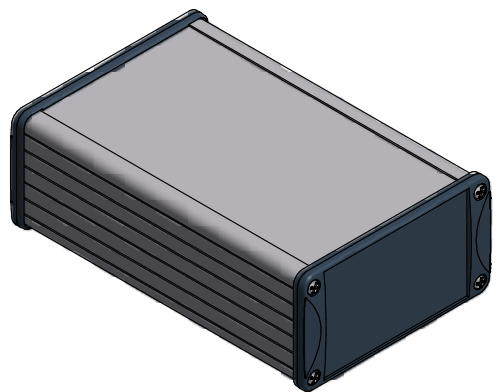

DETAIL AA



Fits 160mm (6.299") X 100mm (3.937") PCB  
 Note: Aluminum extrusion has a tolerance of +/- .02"

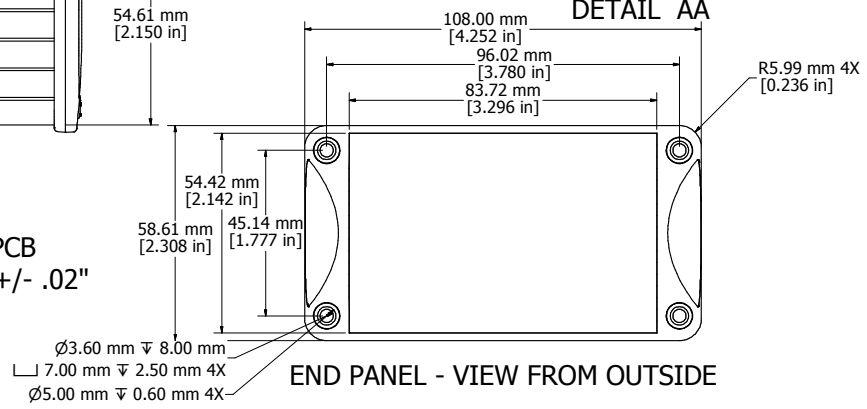

END PANEL - VIEW FROM OUTSIDE

**PROTECTION TO IP 65**

Enclosures can be Factory Modified ( Milling, Drilling, Printing etc. )  
 Contact Factory [mjm@hammondmfg.com](mailto:mjm@hammondmfg.com) for quotes  
 Solid models of this enclosure available in STEP or IGES.

**NOTE**

Purchased assembly includes box, end panels, stainless steel #6 Taptight screws, self adhesive rubber feet, gaskets and O-Rings.  
 Box made from Extruded Aluminum 6063.  
 End panels made from Type 380 Diecast Aluminum with a black powder paint finish.

**WATERPROOF 1457N1601**

**PART NUMBERS**

Clear anodized box with black powder painted end panels	1457N1601
Black powder painted box and end panels	1457N1601BK
<b>EMI/RFI SHIELDED (IP 54)</b>	
Clear anodized box with black powder painted end panels	1457N1601E
Black powder painted box and end panels	1457N1601EBK

**ACCESSORIES**

See website for accessories.

**HAMMOND MANUFACTURING™**  
**1457N1601**  
[www.hammondmfg.com](http://www.hammondmfg.com)