

PART NUMBER	POSITION 1	POSITION 2	POSITION 3	POSITION 4
568-0141-1113	RED DIFFUSED	RED DIFFUSED	RED DIFFUSED	RED DIFFUSED
568-0142-2223	GREEN DIFFUSED	GREEN DIFFUSED	GREEN DIFFUSED	GREEN DIFFUSED
568-0143-3333	YELLOW DIFFUSED	YELLOW DIFFUSED	YELLOW DIFFUSED	YELLOW DIFFUSED

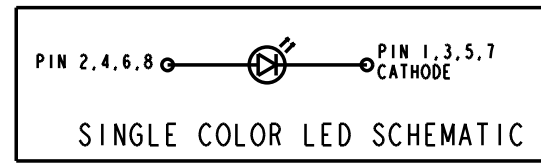

REV.	ECN NO.	REVISIONS	DRN.	CKD.	APP.	DATE
A		NEW RELEASE	TC			

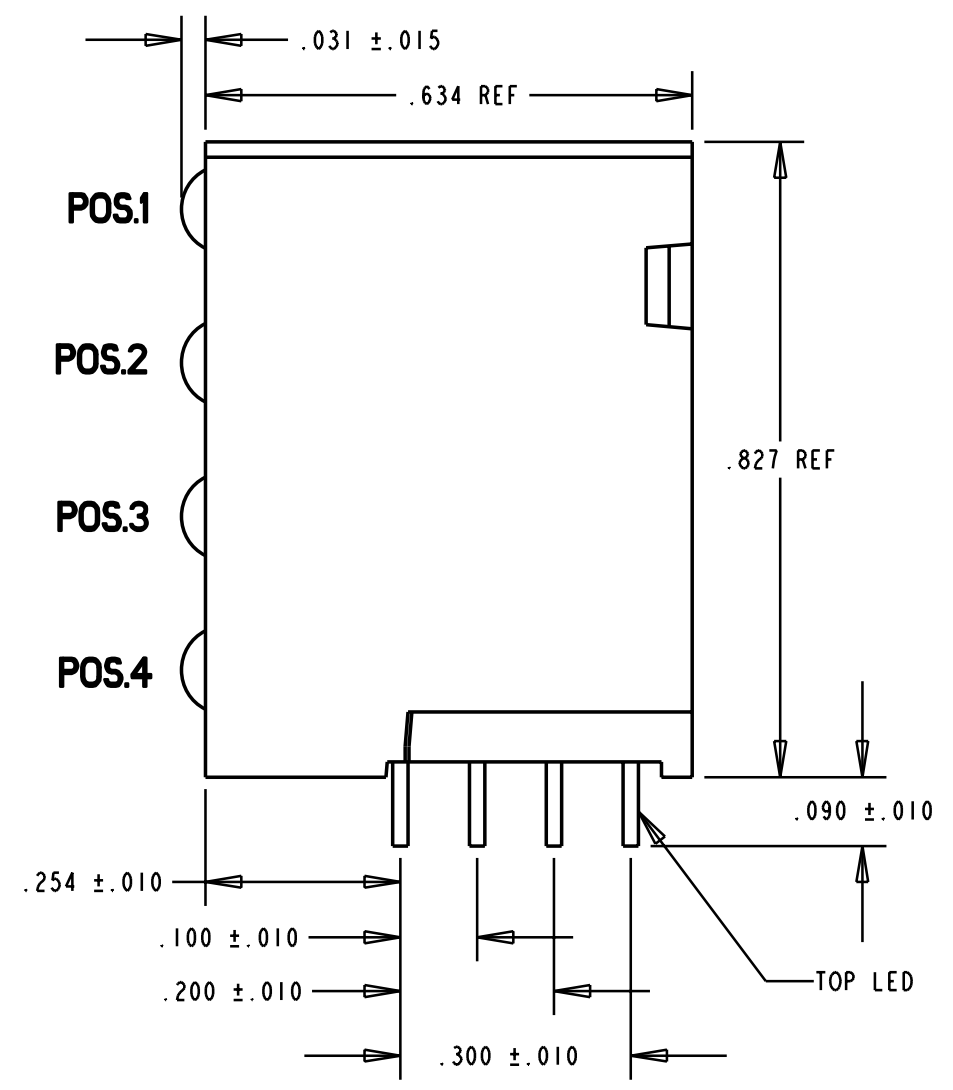
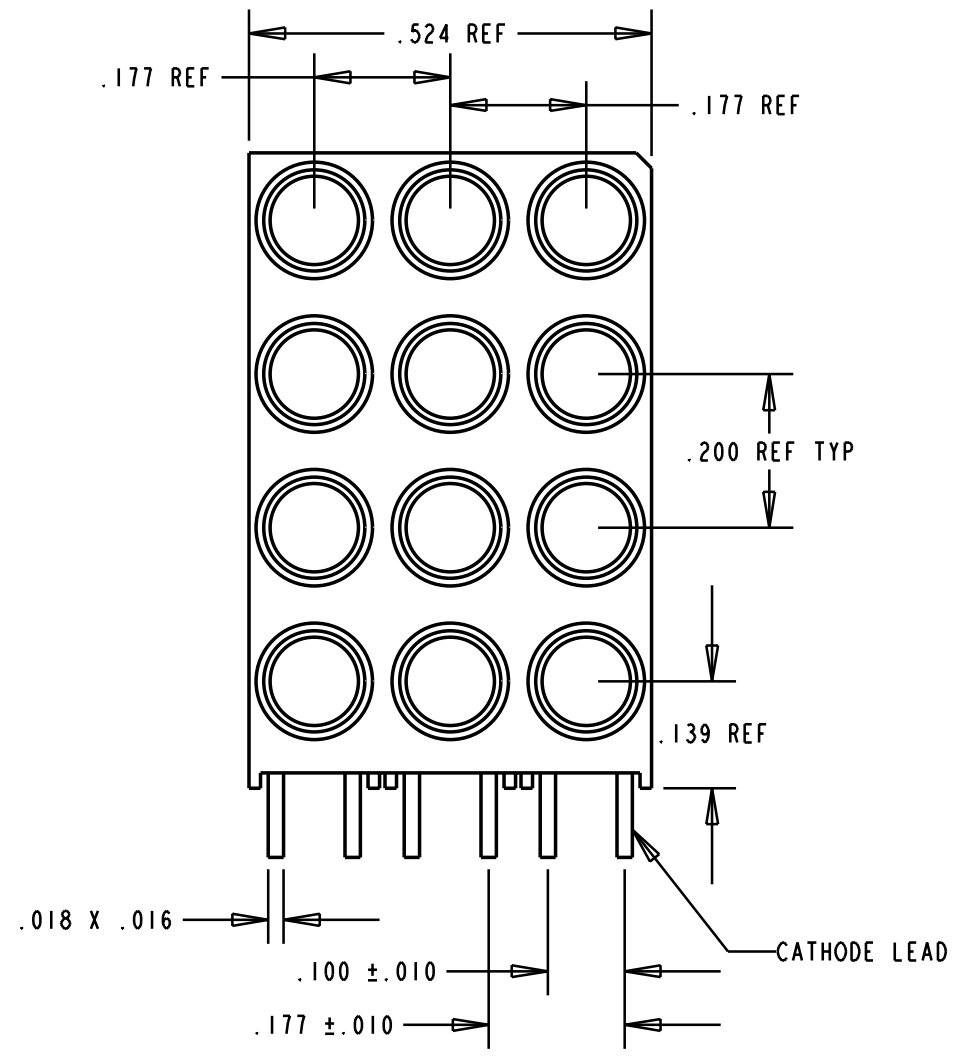

- NOTES:
- LEADS TO FIT INTO HOLES SPACED AS PER HOLE PATTERN
  - LEADS TO BE FREE OF DEFORMATION AFTER BENDING AND CUTTING
  - PIN NUMBERS FOR REFERENCE ONLY, DESIGNATION NON-EXISTENT ON PART
  - LED LEAD DIMENSIONS SHOWN ARE MEASURED AT HOUSING EXIT
  - PACKAGING =  
BLOCKS ARE PLACED IN CLEAR ANTISTATIC TRAY  
105 BLOCKS PER TRAY
  - DIALIGHT PART NUMBER: 568-014X-XXX3

OPERATING CHARACTERISTICS AT 25°C AMBIENT						
CHARACTERISTICS	LED COLOR	MIN	TYP	MAX	UNITS	TEST CONDITIONS
LUMINOUS INTENSITY	RED	7.4	10.0		mcd	I <sub>f</sub> = 10 mA
	GREEN	4.7	12.6			
	YELLOW	7.4	10.0			
FORWARD VOLTAGE	RED		2.0	2.8	V	I <sub>f</sub> = 20 mA
	GREEN		2.1	2.8		
	YELLOW		2.1	2.8		
REVERSE CURRENT	ALL		100		µA	V <sub>R</sub> = 5 V
PEAK WAVELENGTH	RED		635		nm	
	GREEN		565			
	YELLOW		585			
VIEWING ANGLE	ALL		60		Degree	
CAPACITANCE	RED		20		pF	V <sub>f</sub> = 0, f = 1MHz
	GREEN		35			
	YELLOW		15			

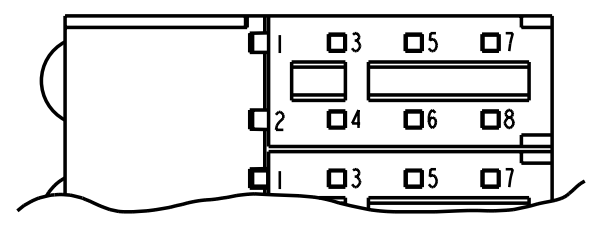
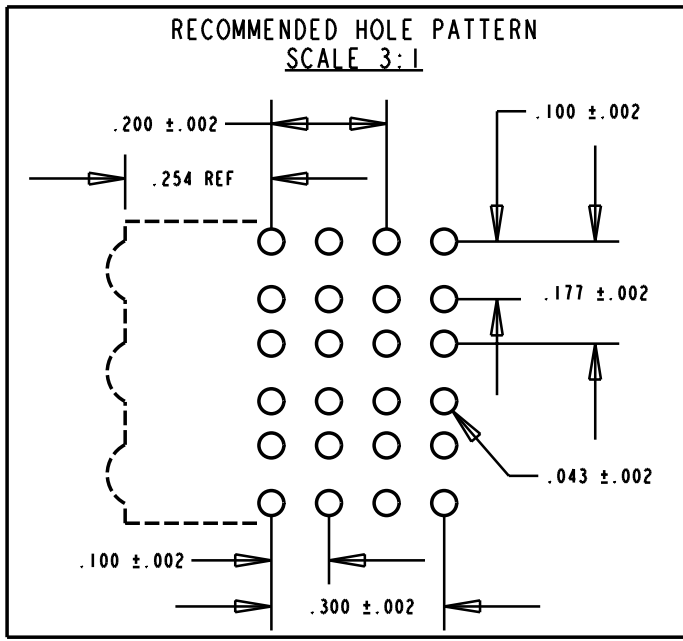

ABSOLUTE MAXIMUM RATING AT 25°C AMBIENT				
	UNITS	RED	GREEN	YELLOW
POWER DISSIPATION	mW	100	100	60
DERATE LINEARLY FROM 50°C	mA/°C	0.4	0.4	0.25
CONTINUOUS FORWARD CURRENT	mA	30	30	20
PEAK FORWARD CURRENT (1/10 DUTY CYCLE, 0.1 ms PULSE WIDTH)	mA	120	120	80
LEAD SOLDERING TEMPERATURE, 5 SEC., 1/16" FROM BODY	°C	260	260	260
OPERATING TEMPERATURE	°C	-55 TO +100	-55 TO +100	-55 TO +100
STORAGE TEMPERATURE	°C	-55 TO +100	-55 TO +100	-55 TO +100

THIS DRAWING AND THE CONTENTS HEREIN ARE CONFIDENTIAL AND THE SOLE PROPERTY OF DIALIGHT. REPRODUCTION OF THIS DRAWING OR CONSTRUCTION OF ANY PARTS WITHIN THIS DRAWING ARE FORBIDDEN WITHOUT THE WRITTEN CONSENT OF DIALIGHT.

SCALE 4:1	DRAWING NUMBER	REV
ALL DIM'S IN: INCHES	C-16594	A
TOLERANCES: UNLESS OTHERWISE SPECIFIED	TITLE	
FRACTIONS: ±1/64	4X3 CBI ARRAY BLOCK	
DECIMALS (.XX): ±.020	MATERIAL	
DECIMALS (.XXX): ±.015	Dialight	
DECIMALS (.XXXX): ±.010	1913 ATLANTIC AVE.	
ANGLES: ±3°	MANASQUAN, N. J. 08736	
FINISH:	FSCM 83330	SHEET OF FAMILY TABLE: