



SKYWORKS®

APS3606

Active Splitter for Analog/Digital
CATV Set-Top Boxes
PRELIMINARY DATA SHEET - Rev 1.0

FEATURES

- Single Input, Triple Output Design
- High Linearity, Low Distortion Outputs Support Video Tuner Applications
- Wideband Operation: To Above 1 GHz
- 4.3 dB Typical Noise Figure at 3.5 dB Gain
- Extended Dynamic Range Gain Control, Independent for each RF path
- Single +5 V Supply
- Balanced 75 Ohm Inputs/Outputs
- RoHS Compliant/Lead Free

APPLICATIONS

- CATV Set-Top Boxes with Multiple Tuners, and Analog or Analog/Digital input signals.

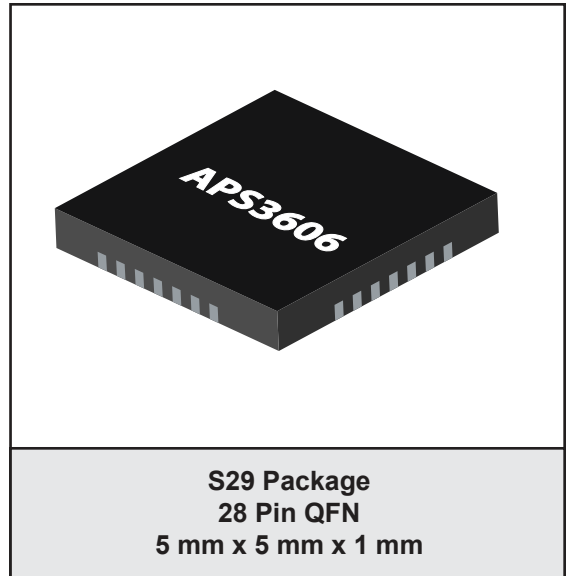

PRODUCT DESCRIPTION

This active splitter accepts a balanced RF input in the 50 MHz to 1.1 GHz frequency range and provides three balanced RF outputs with minimal degradation in signal quality. The single-package surface mount device amplifies the input signals using highly linear, low noise amplification stages, and couples the amplified signal to three separate output paths that can drive video tuner inputs.

Each of the RF paths includes independent Gain Control. The overall linearity of each path is maintained across a wide gain range, ensuring low distortion

effects on each output signal.

Requiring only a single +5 Volt supply, the active splitter design is implemented using the GaAs MESFET process. The RoHS-compliant surface mount packaging makes the device ideal for use in today's multiple-tuner set-top boxes for Cable TV.

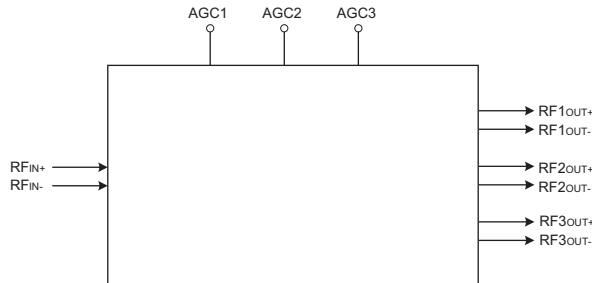

Figure 1: Functional Block Diagram

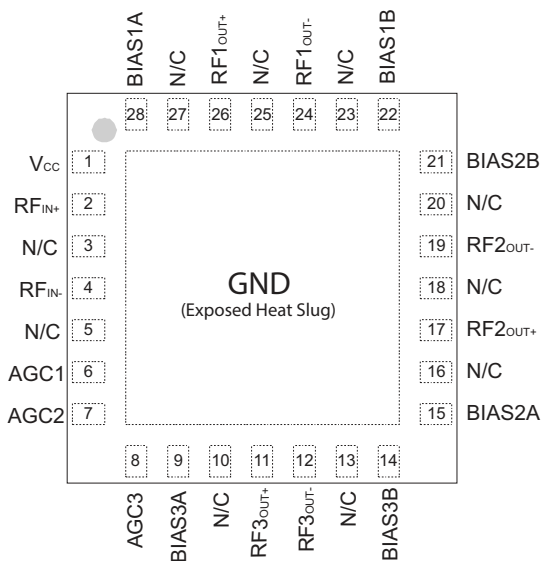

Figure 2: Pinout (X-ray Top View)

Table 1: Pin Description

PIN	NAME	DESCRIPTION	PIN	NAME	DESCRIPTION
1	V _{CC}	Supply Voltage	28	BIAS1A	RF1 Bias
2	RF _{IN+}	RF Input (+)	27	N/C	No Connection
3	N/C	No Connection	26	RF1 _{OUT+}	RF1 Output (+)
4	RF _{IN-}	RF Input (-)	25	N/C	No Connection
5	N/C	No Connection	24	RF1 _{OUT-}	RF1 Output (-)
6	AGC1	RF1 Gain Control Input	23	N/C	No Connection
7	AGC2	RF2 Gain Control Input	22	BIAS1B	RF1 Bias
8	AGC3	RF3 Gain Control Input	21	BIAS2B	RF2 Bias
9	BIAS3A	RF3 Bias	20	N/C	No Connection
10	N/C	No Connection	19	RF2 _{OUT-}	RF2 Output (-)
11	RF3 _{OUT+}	RF3 Output (+)	18	N/C	No Connection
12	RF3 _{OUT-}	RF3 Output (-)	17	RF2 _{OUT+}	RF2 Output (+)
13	N/C	No Connection	16	N/C	No Connection
14	BIAS3B	RF3 Bias	15	BIAS2A	RF2 Bias

ELECTRICAL CHARACTERISTICS

Table 2: Absolute Minimum and Maximum Ratings

PARAMETER	MIN	MAX	UNIT	COMMENTS
Supply Voltage (V_{CC})	0	+8	V	
AGC Input Voltage (V_{AGC})	0	+5	V	
RF Input Power (P_{IN})	-	+25	dBmV	differential into 75 \square

Stresses in excess of the absolute ratings may cause permanent damage. Functional operation is not implied under these conditions. Exposure to absolute ratings for extended periods of time may adversely affect reliability.

Table 3: Operating Ranges

PARAMETER	MIN	TYP	MAX	UNIT	COMMENTS
Operating Frequency (f)	50	-	1100	MHz	
Supply Voltage (V_{CC})	-	+5	-	V	
AGC Input Voltage (V_{AGC})	+0.3	-	+3.0	V	max. gain at +3 V
RF Input Power (P_{IN})	-15	-	+15	dBmV	differential into 75 \square
Case Temperature (T_C)	-20	-	+85	$^{\circ}$ C	

The device may be operated safely over these conditions; however, parametric performance is guaranteed only over the conditions defined in the electrical specifications.

Table 4: DC Electrical Specifications
($T_c = +25\text{ }^\circ\text{C}$, $V_{cc} = +5\text{ V}$, $75\ \Omega$ system)

PARAMETER	MIN	TYP	MAX	UNIT	COMMENTS
Current Consumption	-	175	240	mA	from +5 V supply
ACG Input Leakage Current	-	50	-	μA	each AGC input

Table 5: Video Tuner Path AC Electrical Specifications
($T_c = +25\text{ }^\circ\text{C}$, $V_{cc} = +5\text{ V}$, $75\ \Omega$ system)

PARAMETER	MIN	TYP	MAX	UNIT	COMMENTS
Gain at Maximum AGC	3	3.5	-	dB	at 1 GHz
Gain at Minimum AGC	-	-28	-	dB	at 1 GHz
AGC Range	28	32	-	dB	at 1 GHz; $V_{AGC} = 0.5\text{ V}$ to 3.0 V
Noise Figure	-	4.3	-	dB	at maximum gain
CTB (1)	-	-70	-66	dBc	
CSO (1)	-	-70	-66	dBc	
XMOD (1)	-	-67	-	dBc	
Isolation Between Output and Any other Output Port	-	35	-	dB	
Isolation Between Input and Output	-	35	-	dB	
Input Return Loss	-	-12	-	dB	$75\ \Omega$ differential input
Output Impedance	-	75	-	Ω	differential

Notes:

(1) 132 channels, +6 dBmV flat output, up to +15 dBmV flat input

APPLICATION INFORMATION

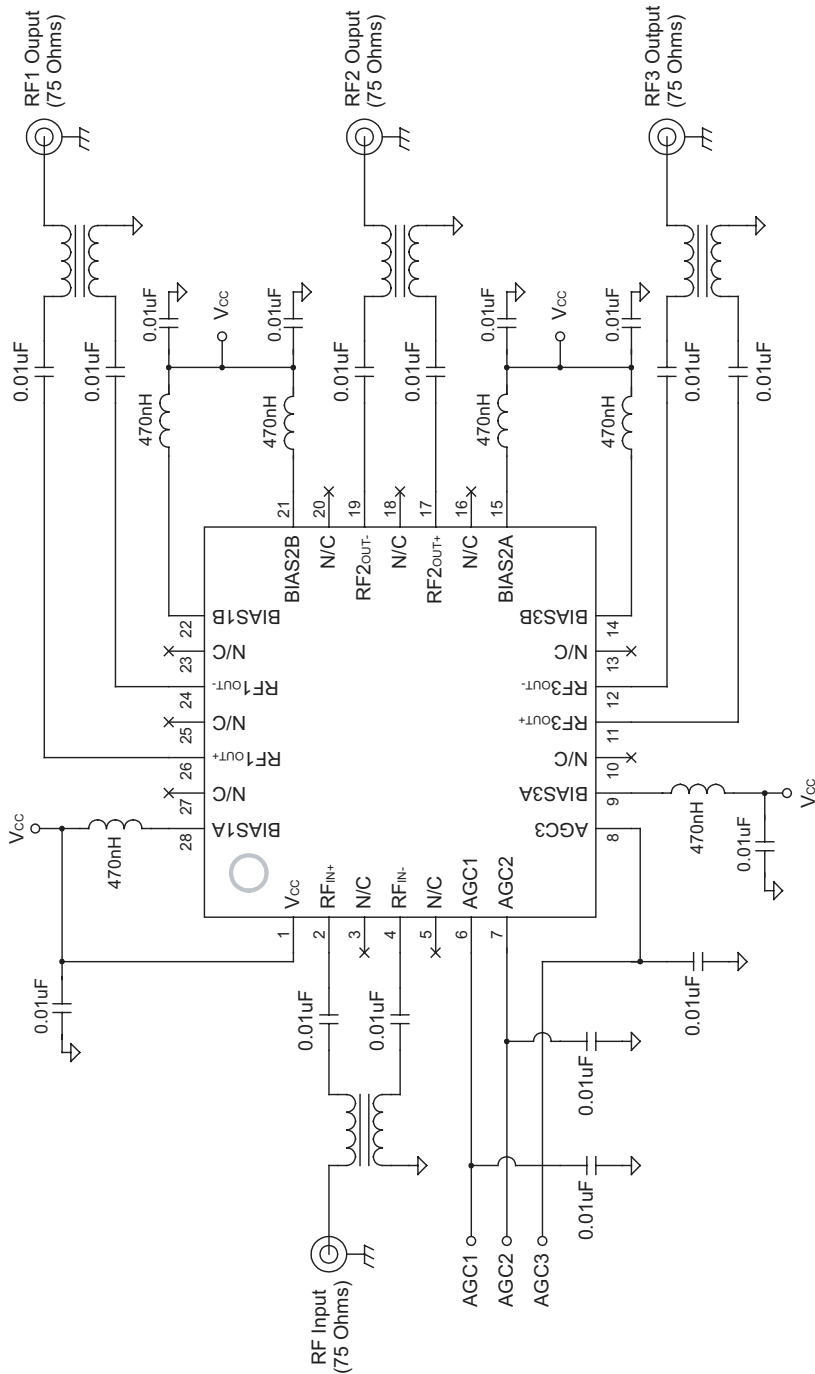
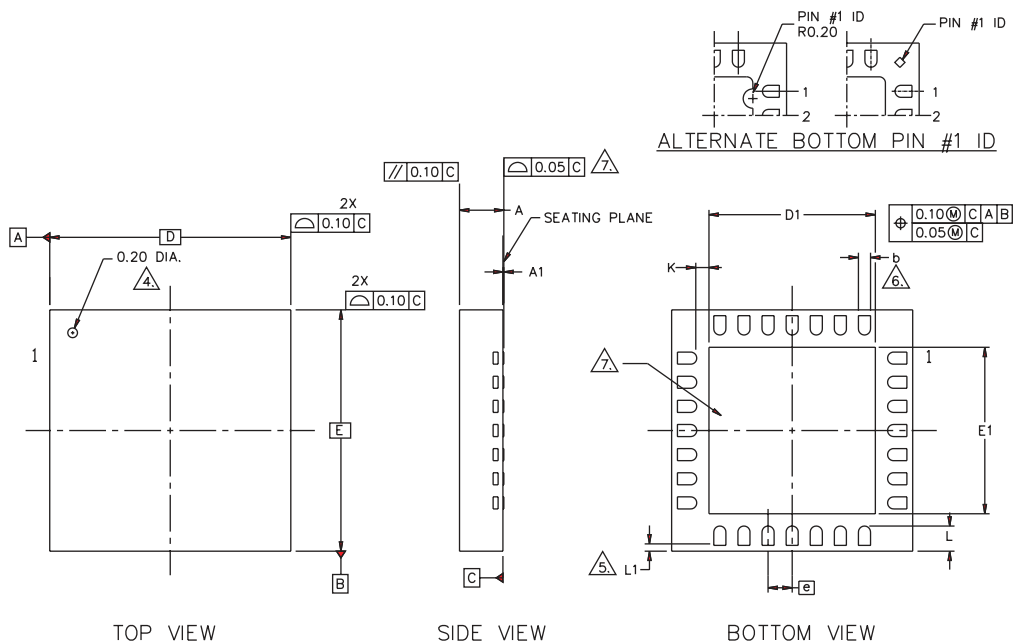

Figure 3: Application Circuit

PACKAGE OUTLINE



NOTES :

1. ALL DIMENSIONS ARE IN MILLIMETERS.
2. MAX. PACKAGE WARPAGE IS 0.05 mm.
3. MAXIMUM ALLOWABLE BURRS IS 0.076 mm IN ALL DIRECTIONS.
4. PIN #1 ID ON TOP WILL BE LASER MARKED.
5. A MAXIMUM 0.15mm PULL BACK (L1) MAYBE PRESENT, L MINUS L1 TO BE EQUAL TO OR GREATER THAN 0.30mm.
6. DIMENSION b APPLIES TO METALLIZED TERMINAL AND IS MEASURED BETWEEN 0.15 AND 0.30mm FROM TERMINAL TIP. IF THE TERMINAL HAS THE OPTIONAL RADIUS ON THE OTHER END OF THE TERMINAL, THE DIMENSION b SHOULD NOT BE MEASURED IN THAT RADIUS AREA.
7. BILATERAL COPLANARITY ZONE APPLIES TO THE EXPOSED HEAT SINK SLUG AS WELL AS THE TERMINALS.
8. REFERENCE JEDEC OUTLINE MO-220.

S V M B Q L	DIMENSIONS--MM		S V M B Q L	DIMENSIONS--INCHES		S V M B Q L
	MIN.	MAX.		MIN.	MAX.	
A	0.80	1.00	A	0.031	0.039	
A1	0.00	0.05	A1	0.000	0.002	
b	0.18	0.30	b	0.007	0.012	
D	5.00 BSC		D	0.197 BSC		
D1	3.30	3.55	D1	0.130	0.140	
E	5.00 BSC		E	0.197 BSC		
E1	3.30	3.55	E1	0.130	0.140	
e	0.50 BSC		e	0.020 BSC		
K	0.20 MIN.		K	0.007 MIN.		
L	0.30	0.57	L	0.012	0.022	
L1	0.15 MAX.		L1	0.006 MAX.		

Figure 4: S29 Package Outline - 28 Pin 5 mm x 5 mm x 1 mm QFN

ORDERING INFORMATION

ORDER NUMBER	TEMPERATURE RANGE	PACKAGE DESCRIPTION	COMPONENT PACKAGING
APS3606RS29P8	-20 °C to +85 °C	RoHS Compliant 28 Pin 5 mm x 5 mm x 1 mm QFN Package	Tape and Reel, 2500 pieces per Reel

Copyright © 2016 Skyworks Solutions, Inc. All Rights Reserved.

Information in this document is provided in connection with Skyworks Solutions, Inc. ("Skyworks") products or services. These materials, including the information contained herein, are provided by Skyworks as a service to its customers and may be used for informational purposes only by the customer. Skyworks assumes no responsibility for errors or omissions in these materials or the information contained herein. Skyworks may change its documentation, products, services, specifications or product descriptions at any time, without notice. Skyworks makes no commitment to update the materials or information and shall have no responsibility whatsoever for conflicts, incompatibilities, or other difficulties arising from any future changes.

No license, whether express, implied, by estoppel or otherwise, is granted to any intellectual property rights by this document. Skyworks assumes no liability for any materials, products or information provided hereunder, including the sale, distribution, reproduction or use of Skyworks products, information or materials, except as may be provided in Skyworks Terms and Conditions of Sale.

THE MATERIALS, PRODUCTS AND INFORMATION ARE PROVIDED "AS IS" WITHOUT WARRANTY OF ANY KIND, WHETHER EXPRESS, IMPLIED, STATUTORY, OR OTHERWISE, INCLUDING FITNESS FOR A PARTICULAR PURPOSE OR USE, MERCHANTABILITY, PERFORMANCE, QUALITY OR NON-INFRINGEMENT OF ANY INTELLECTUAL PROPERTY RIGHT; ALL SUCH WARRANTIES ARE HEREBY EXPRESSLY DISCLAIMED. SKYWORKS DOES NOT WARRANT THE ACCURACY OR COMPLETENESS OF THE INFORMATION, TEXT, GRAPHICS OR OTHER ITEMS CONTAINED WITHIN THESE MATERIALS. SKYWORKS SHALL NOT BE LIABLE FOR ANY DAMAGES, INCLUDING BUT NOT LIMITED TO ANY SPECIAL, INDIRECT, INCIDENTAL, STATUTORY, OR CONSEQUENTIAL DAMAGES, INCLUDING WITHOUT LIMITATION, LOST REVENUES OR LOST PROFITS THAT MAY RESULT FROM THE USE OF THE MATERIALS OR INFORMATION, WHETHER OR NOT THE RECIPIENT OF MATERIALS HAS BEEN ADVISED OF THE POSSIBILITY OF SUCH DAMAGE.

Skyworks products are not intended for use in medical, lifesaving or life-sustaining applications, or other equipment in which the failure of the Skyworks products could lead to personal injury, death, physical or environmental damage. Skyworks customers using or selling Skyworks products for use in such applications do so at their own risk and agree to fully indemnify Skyworks for any damages resulting from such improper use or sale.

Customers are responsible for their products and applications using Skyworks products, which may deviate from published specifications as a result of design defects, errors, or operation of products outside of published parameters or design specifications.

Customers should include design and operating safeguards to minimize these and other risks. Skyworks assumes no liability for applications assistance, customer product design, or damage to any equipment resulting from the use of Skyworks products outside of stated published specifications or parameters.

Skyworks and the Skyworks symbol are trademarks or registered trademarks of Skyworks Solutions, Inc., in the United States and other countries. Third-party brands and names are for identification purposes only, and are the property of their respective owners. Additional information, including relevant terms and conditions, posted at www.skyworksinc.com, are incorporated by reference.

Skyworks Solutions, Inc.

Phone [781] 376-3000 • Fax [781] 376-3100 • sales@skyworksinc.com • www.skyworksinc.com

Skyworks Proprietary and Confidential information • Products and Product Information are Subject to Change Without Notice