

LOC	DIST	REVISIONS					
		P	LTN	DESCRIPTION	DATE	DWN	APVD
		A		RELEASED PER ECO-08-011133	13MAY2008	ZMR	DLG
		C		REVISED PER ECO-14-016798	19NOV2014	HW	MC
		D		REVISED PER ECO-18-005823	16APR2018	TX	SH

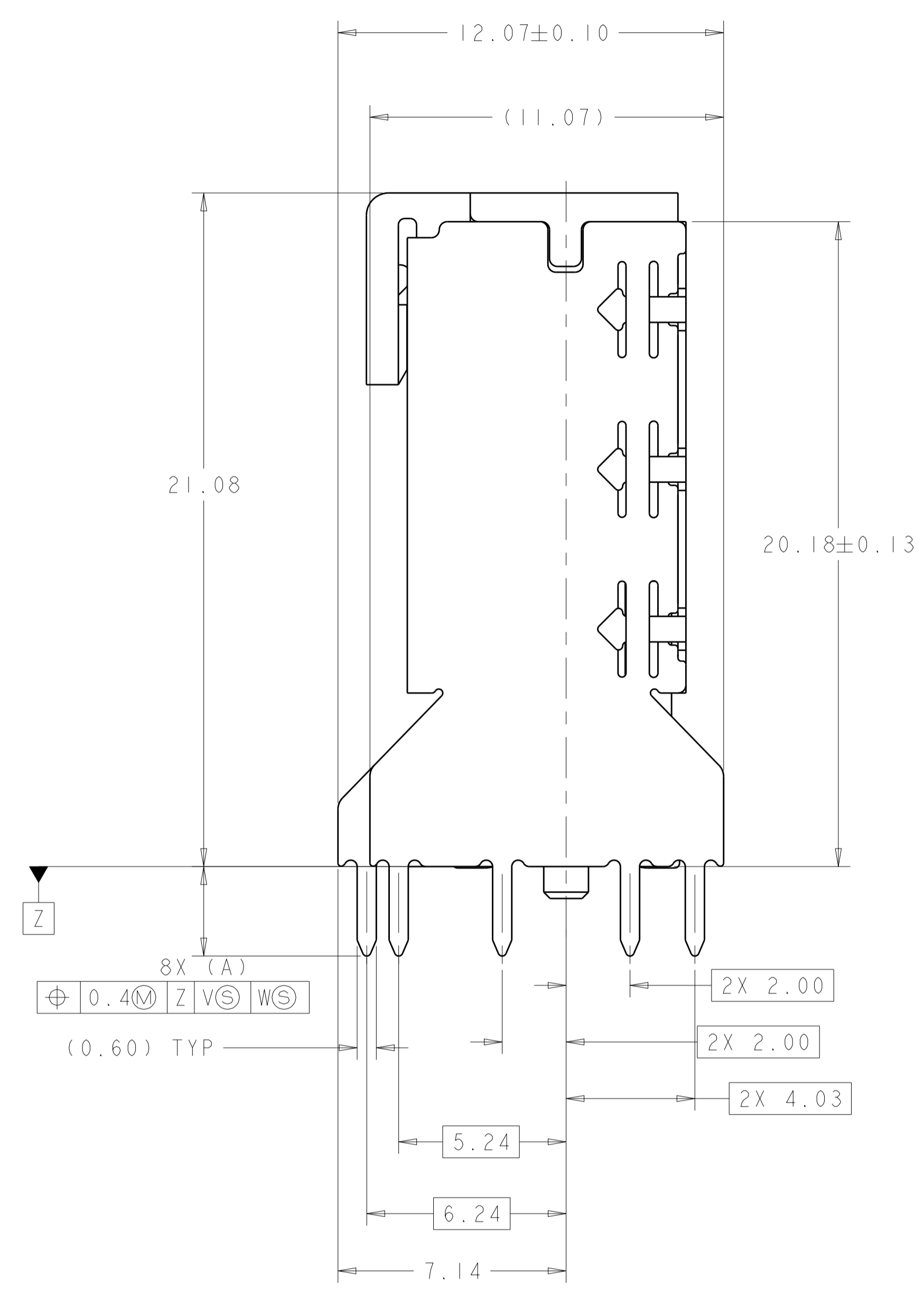

- 1 MATERIAL: HOUSING-LCP, COLOR: BLACK
- 2 MATERIAL: TERMINAL-PHOSPHOR BRONZE PER ASTM B 103.
- 3 FINISH: TERMINAL
0.76µm MIN GOLD PLATE PER ASTM B 488, APPLIES TO INTERFACE AREA AND 2.03µm MIN TIN PLATE SOLDER TAILS, ALL OVER 3.81µm MIN NICKEL PLATE PER QQ-N-290.
- 4 MATERIAL: SHELL-NICKEL-SILVER PER ASTM B 122.
- 5 DATUM AND BASIC DIMENSION ESTABLISHED BY CUSTOMER.
- 6 CONTACT TAILS TO BE 0.25 MAX BELOW FLUSH WITH DATUM Z.
- 7. REFER TO CUSTOMER DRAWING 1888020 FOR CONNECTOR DETAILS.
- 8 FINISH: TERMINAL
0.38µm MIN GOLD PLATE PER ASTM B 488, APPLIES TO INTERFACE AREA AND 2.03µm MIN TIN PLATE SOLDER TAILS, ALL OVER 3.81µm MIN NICKEL PLATE PER QQ-N-290.
- 9 THE ENTIRE AREA OF THE CONNECTOR FOOTPRINT, INDICATED BY THE DASHED LINE, TO BE CONSIDERED THE KEEPOUT AREA FOR COMPONENTS.
- 10 CROSS-HATCHED AREAS REPRESENT ZONES ON THE PCB THAT COME IN CONTACT WITH OR BE IN CLOSE PROXIMITY TO THE PLASTIC HOUSING OR THE CONNECTOR CAGE. INDICATED AREAS TO BE CONSIDERED TRACE FREE

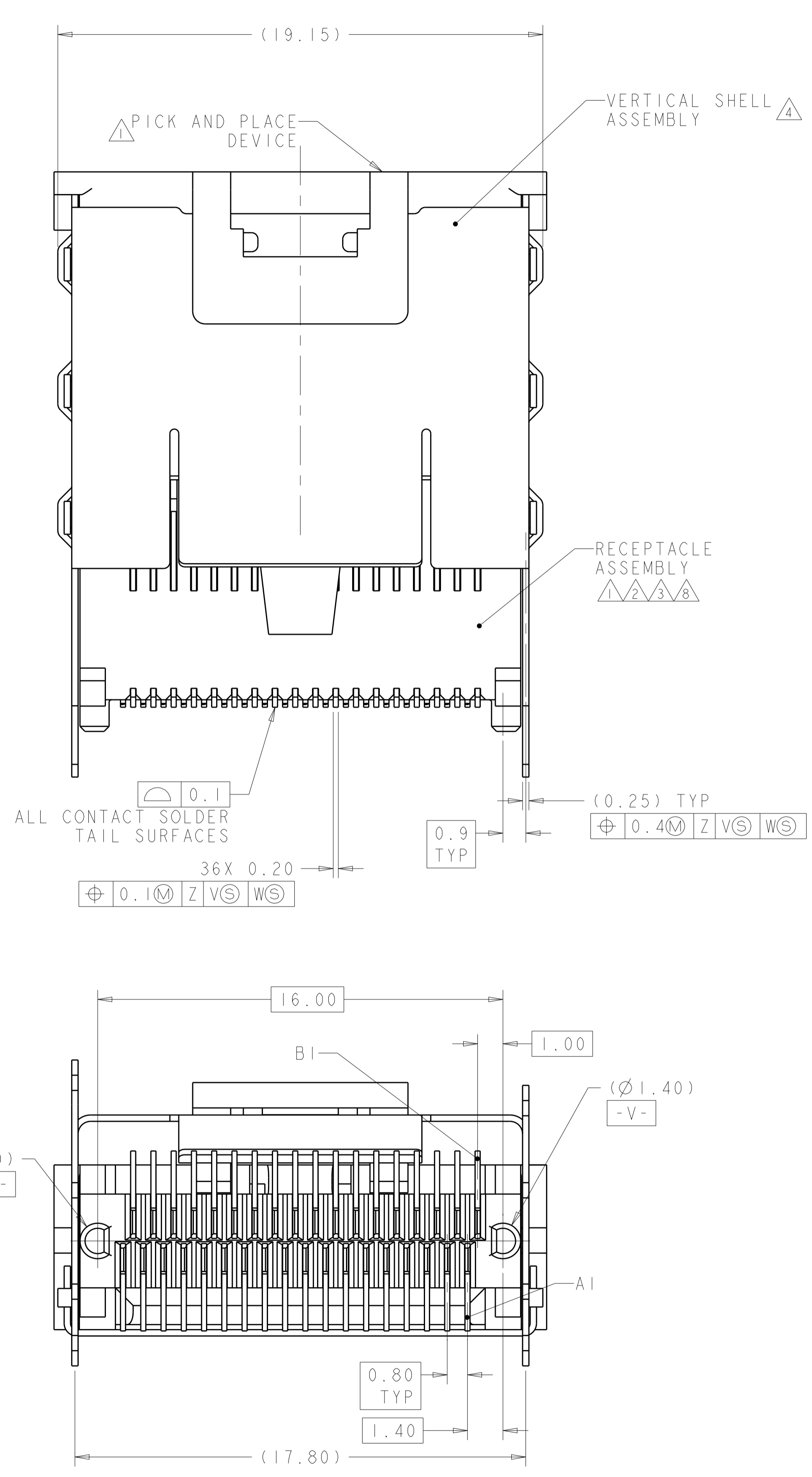
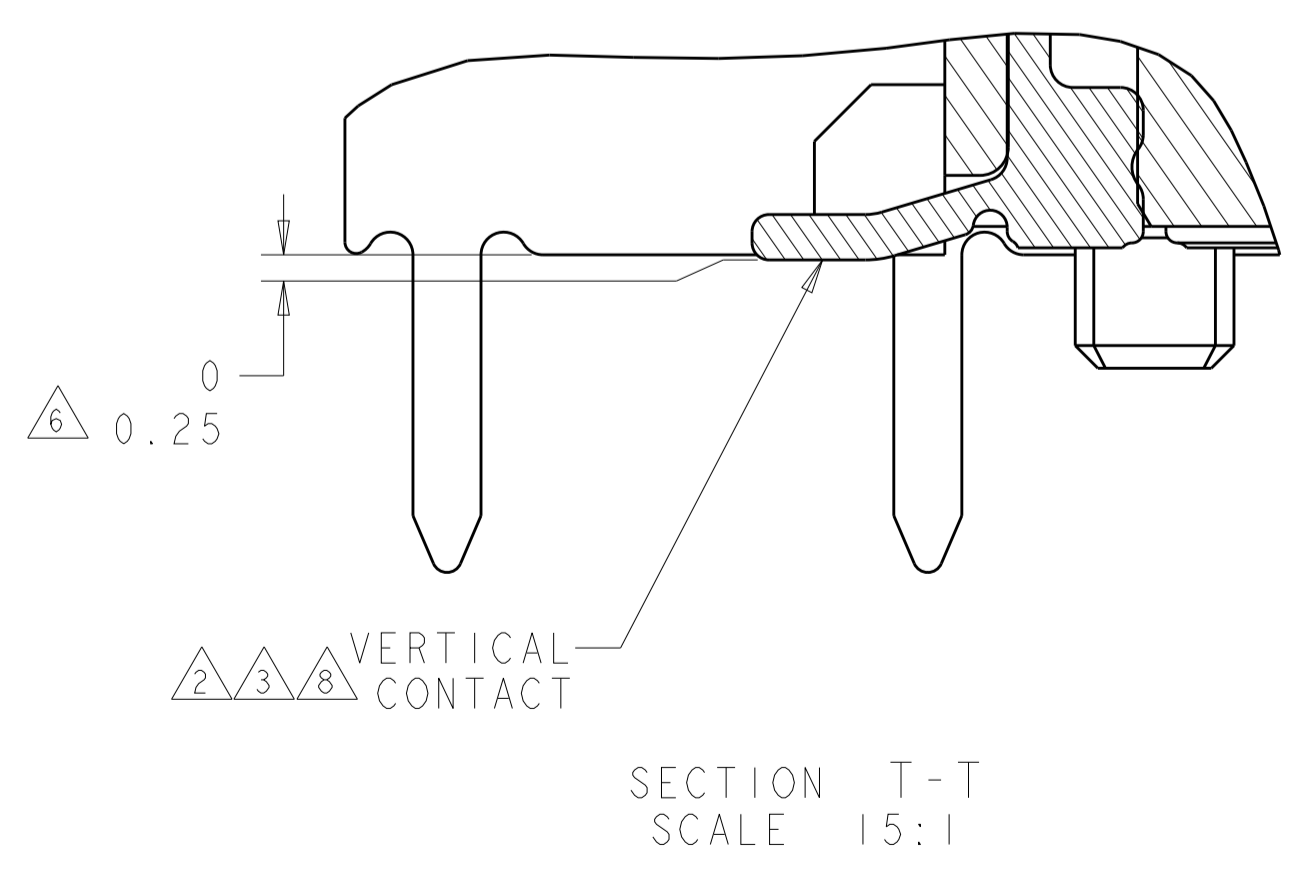
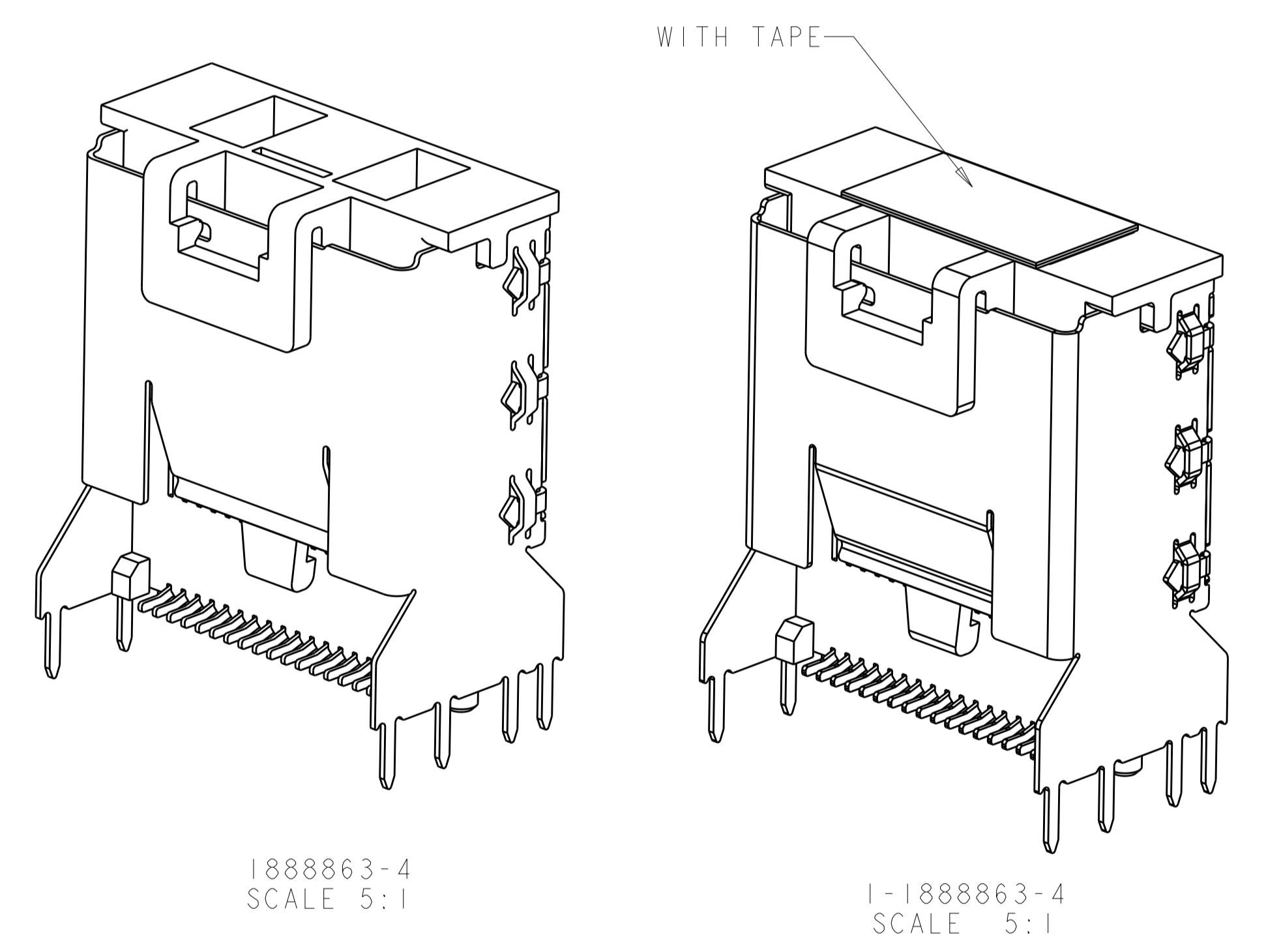

FINISH	DIM A	POSN	PART NUMBER
8	2.00	36	2-1888863-0
	3.50	36	1-1888863-0
3	2.80	36	1888863-9
	3.50	36	1888863-8
	2.80	36	1-1888863-4
	2.80	36	1888863-4

DIMENSIONS: mm 		TOLERANCES UNLESS OTHERWISE SPECIFIED: 0 PLC ± 1 PLC ±0.25 2 PLC ±0.15 3 PLC ± 4 PLC ± ANGLES ±		DWN B. MCMASTER 25JAN07 CHK D. GORENC 25JAN07 APVD D. GORENC 25JAN07 NAME EVERCLEAR Mini-SAS VERTICAL INTERNAL RECEPTACLE ASSEMBLY WITH UNKEYED SHELL PRODUCT SPEC 108-2234 APPLICATION SPEC SIZE CAGE CODE DRAWING NO WEIGHT CUSTOMER DRAWING		Tyco Electronics SCALE 8:1 SHEET 1 OF 2 REV D	
-----------------------	--	---	--	--	--	--	--

LOC		DIST		REVISIONS			
				DESCRIPTION	DATE	DWN	APVD
-	-	-	-	SEE SHEET 1	-	-	-

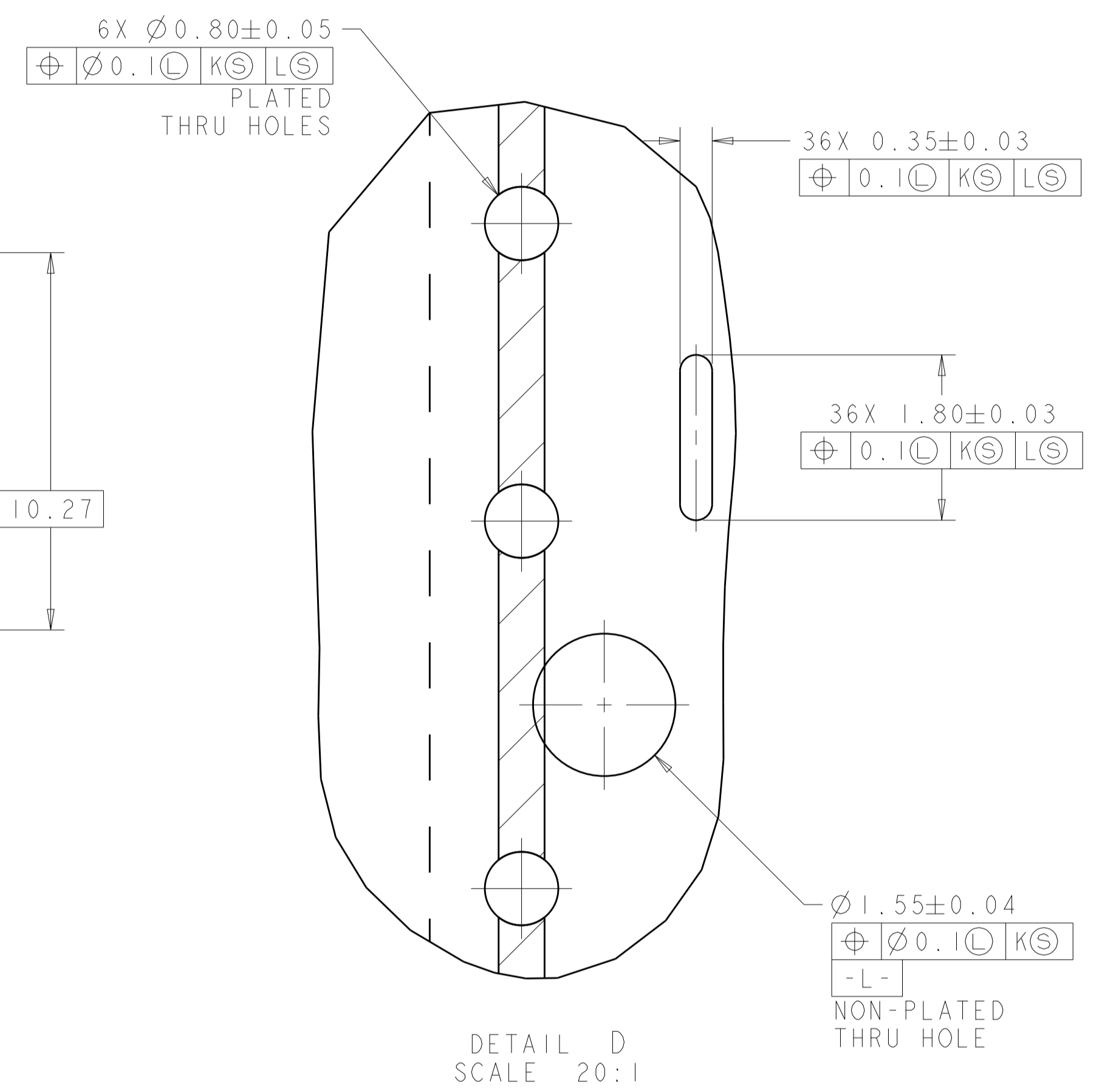
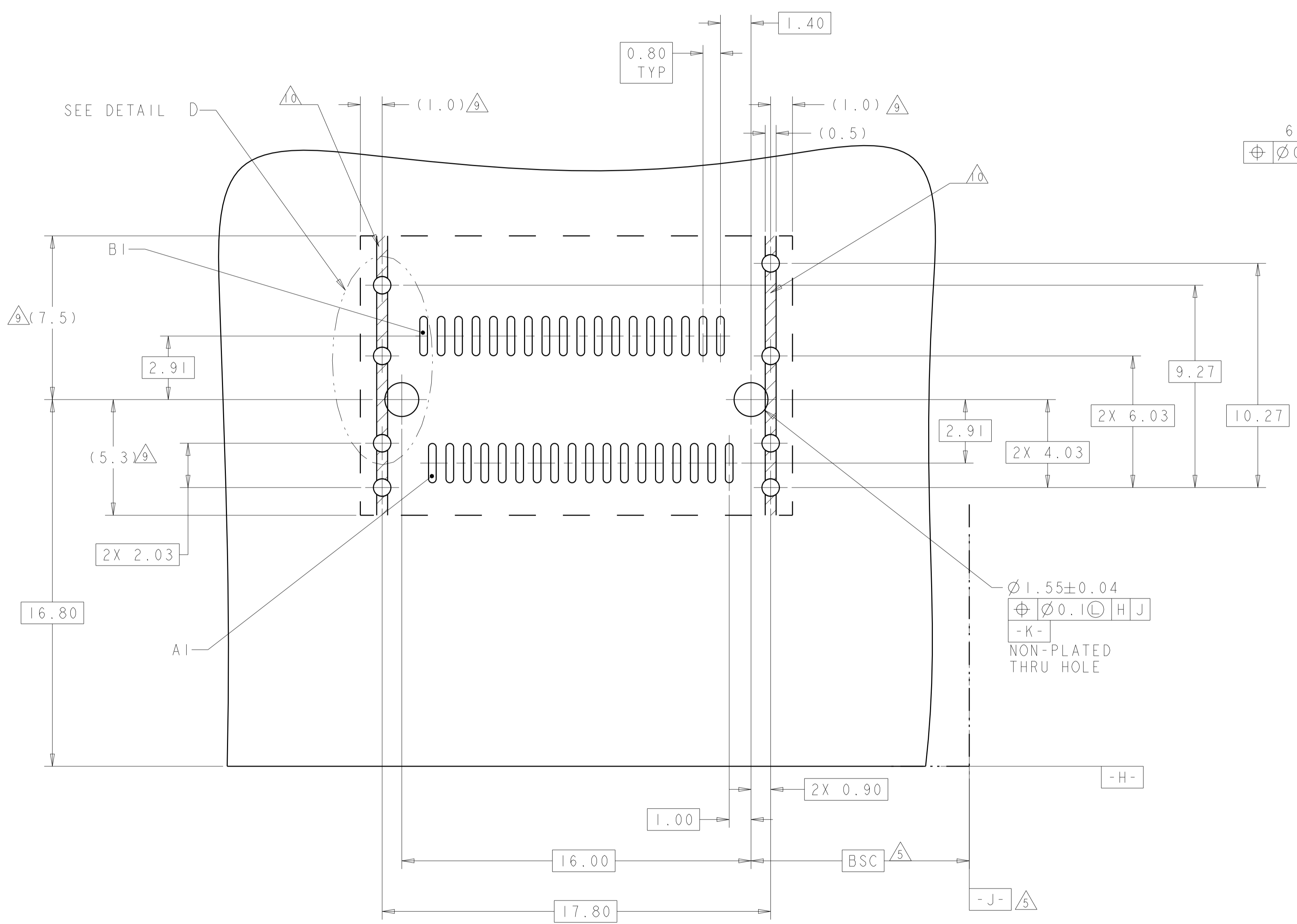

RECOMMENDED PCB LAYOUT
 SCALE 8:1

<small>THIS DRAWING IS UNPUBLISHED. IT IS THE PROPERTY OF TYCO ELECTRONICS CORPORATION. IT IS TO BE USED ONLY FOR THE PURPOSES AND IN THE QUANTITIES SPECIFIED IN THE ORDER. IT IS TO BE RETURNED TO TYCO ELECTRONICS CORPORATION IF NOT SO. IT IS TO BE DESTROYED IF NOT SO. IT IS TO BE DESTROYED IF NOT SO.</small>		DWN: B. MCMASTER 25JAN07 CHK: D. GORENC 25JAN07 APVD: D. GORENC 25JAN07	Tyco Electronics NAME: EVERCLEAR Mini-SAS VERTICAL INTERNAL RECEPTACLE ASSEMBLY WITH UNKEYED SHELL PRODUCT SPEC: 108-2234 APPLICATION SPEC:
DIMENSIONS: mm 0 PLC ±0.25 1 PLC ±0.15 2 PLC ±0.15 3 PLC ±0.15 4 PLC ±0.15 ANGLES ±0.15	TOLERANCES UNLESS OTHERWISE SPECIFIED:	SIZE: A1 CAGE CODE: C=1888863 DRAWING NO:	RESTRICTED TO:
MATERIAL: TBD	FINISH: -	WEIGHT: -	CUSTOMER DRAWING
SCALE: 6:1		SHEET: 2 OF 2	REV: D