

| MATERIAL NUMBER | ENGINEERING NUMBER | FINISHED LENGTH |
|-----------------|--------------------|------------------|
| 1201088181 | E11A06006M005 | 0.5M [1FT 8 IN] |
| 1201080366 | E11A06006M600 | 60M[196FT 10 IN] |
| 1201080533 | E11A06006T100 | 100M[328FT 1 IN] |

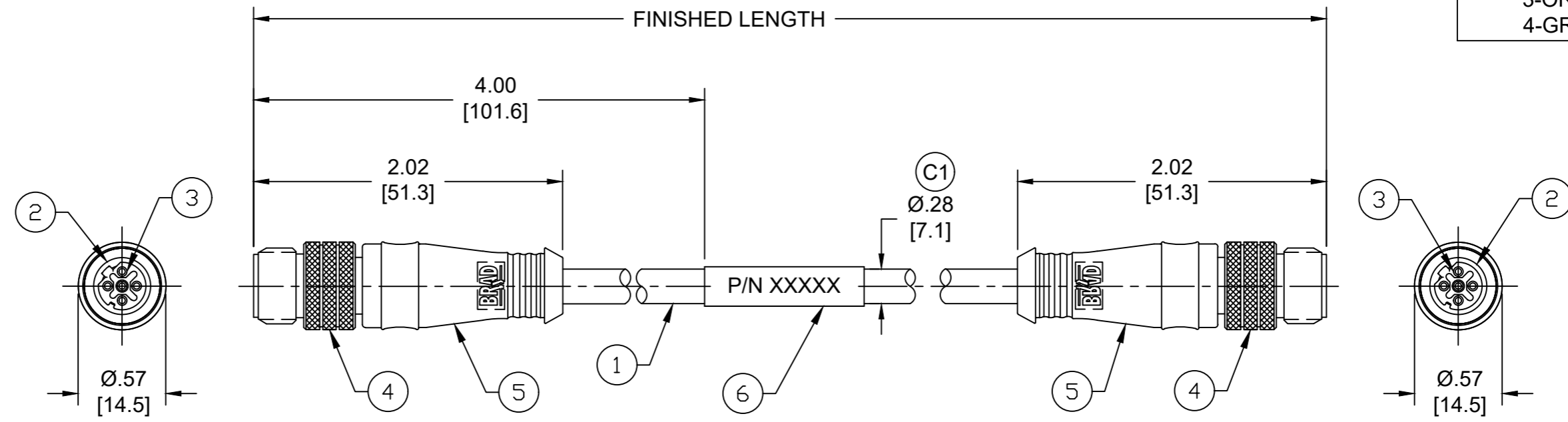
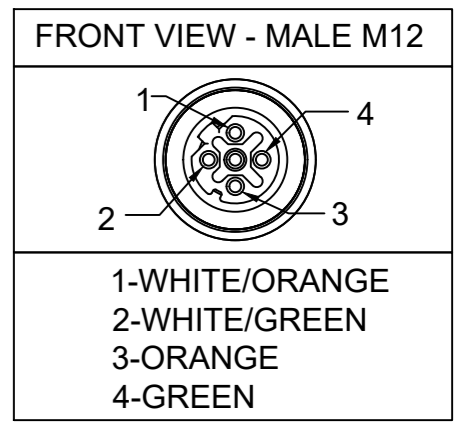

- NOTES:
1. MATERIAL: AS NOTED
 2. FINISH: AS NOTED
 3. ELECTRICAL:
VOLTAGE: 30V AC/DC
CURRENT: 1.5A
 4. TEMP RATING: -20°TO +75°C (C1)
 5. PROTECTION: IP67 (WHEN MATED)
 6. COUPLING THREAD: M12X1
 7. UL LISTED FILE: E361772 (C1)
 8. ALL DIMENSIONS ARE FOR REFERENCE UNLESS TOLERANCED OR NOTED OTHERWISE

PART NUMBER LEGEND
E11A06006M005

FINISHED LENGTH
M005 - 0.5 METER
M010 - 1 METER
M200 - 20 METER
T100 - 100 METER

(C1) CABLE LENGTH TOLERANCES

| | |
|--------------------------|-------------------------|
| <.3M [1FT]: | +19mm-0 [+ .75in-0] |
| .3 - .9M [1 - 3FT]: | +44.5mm-0 [+1.75in-0] |
| .9 - 1.8M [3 - 6FT]: | +55.6mm-0 [+2.19in-0] |
| 1.8 - 3.7M [6 - 12FT]: | +88.9mm-0 [+3.50in-0] |
| 3.7 - 7.3M [12 - 24FT]: | +165.1mm-0 [+6.50in-0] |
| 7.3-14.6M [24 - 48FT]: | +317.5mm-0 [+12.50in-0] |
| 14.6 - 30.5M [48-100FT]: | +622.3mm-0 [+24.50in-0] |
| OVER 30M [100FT] | +2% OF FINISHED LENGTH |

| ITEM | DESCRIPTION | MATERIAL | FINISH |
|------|---------------|--------------|--------------------|
| 6 | WRAP LABEL | VINYL | BLACK/WHITE |
| 5 | OVERMOLD | PUR | BLACK |
| 4 | COUPLING NUT | BRASS | NICKEL PLATED |
| 3 | CONTACT PIN | COPPER ALLOY | GOLD/NICKEL PLATED |
| 2 | MALE INSERT | PUR | BLACK |
| 1 | #24 AWG CABLE | TPE JACKET | BLUE |

| | | | | |
|--|---|----------------------------|------------------------------|--|
| FUNCTIONAL SYMBOLS F=0 E=0 P=0 | THIS DRAWING CONTAINS INFORMATION THAT IS PROPRIETARY TO MOLEX ELECTRONIC TECHNOLOGIES, LLC AND SHOULD NOT BE USED WITHOUT WRITTEN PERMISSION | | | |
| | DIMENSION UNITS | SCALE | | |
| | INCH/MM | NTS | EC NO: 703079 | |
| | GENERAL TOLERANCES (UNLESS SPECIFIED) | | DRWN: ABENJAMINLW 2021/10/27 | |
| 4 PLACES ±---- | | CHK'D: RSTONE 2022/04/12 | | |
| 3 PLACES ±---- | | APPR: BWOODMAN 2022/04/18 | | |
| 2 PLACES ±---- | | INITIAL REVISION: | | |
| 1 PLACE ±---- | | DRWN: BARDEN 2013/02/15 | | |
| 0 PLACES ±---- | | APPR: JFMURPHY 2013/04/18 | | |
| ANGULAR TOL ± ---- ° | | DOCUMENT NUMBER | | |
| DRAFT WHERE APPLICABLE MUST REMAIN WITHIN DIMENSIONS | | SD-120108-052 | | |
| THIRD ANGLE PROJECTION | | DOC TYPE/DOC PART/REVISION | | |
| DRAWING | | PSD 001 C1 | | |
| SERIES | | | | |
| B-SIZE 120108 | | | | |
| MATERIAL NUMBER | | | | |
| SEE CHART | | | | |
| CUSTOMER | | | | |
| FORD | | | | |
| SHEET NUMBER | | | | |
| 1 OF 1 | | | | |