

## SSF29 SERIES

### HIGH PRESSURE SIDE MOUNT SWITCH



The SSF29 type is a side mount vertical switch designed to give reliable switching at higher pressures, up to 40 bar. The switch is mounted in the side of the tank, from the inside, so requires access to the inside of the tank.

They are manufactured in 316L stainless steel and will work in liquids of SG 0.7 minimum.

The switch action may be reversed by removing the float, inverting and then refitting it to the stem.

### Features

- Operates in pressure up to 40 bar
- Internal side mount vertical switch
- Stainless steel 316L
- User configurable N/O (make on rise) or N/C (make on fall) switch action
- Operating temperature to 120°C

## SPECIFICATIONS

### Technical

<b>Mounting Style</b>	Internal
<b>Mounting Thread</b>	1/8" BSP
<b>Float &amp; Stem Material</b>	316 grade SS
<b>Maximum Temperature</b>	120°C
<b>Maximum Pressure</b>	40 bar
<b>Float SG</b>	0.6
<b>Minimum Fluid SG</b>	0.7
<b>Cable Length - Standard</b>	100cm
<b>Cable Size</b>	17/0.10 - AWG22
<b>Cable Conductor Material</b>	Tinned copper
<b>Cable Sheath Material</b>	XLPE
<b>Cable Temperature Rating</b>	125°C
<b>Sealing Gasket</b>	Not supplied
<b>Tightening Torque for Fixing Nut</b>	2.0kg/cm

### Electrical

<b>Contact Form</b>		N/O (N/C)
<b>Switching Power Max</b>	VA	50
<b>Switching Voltage AC Max</b>	V	300
<b>Switching Voltage DC Max</b>	V	300
<b>Switching Current Max</b>	A	0.5

All ratings are for resistive load only.

# STANDARD PARTS

	Material	Max Power	Max Pressure	Leadouts
<b>SSF29X100</b>	SS 316L	50VA	40 bar	100cm XLPE 17/0.1

Custom versions can be made for particular applications. Please contact Sensata with your requirements.

## DIMENSIONS

All dimensions are in millimeters.

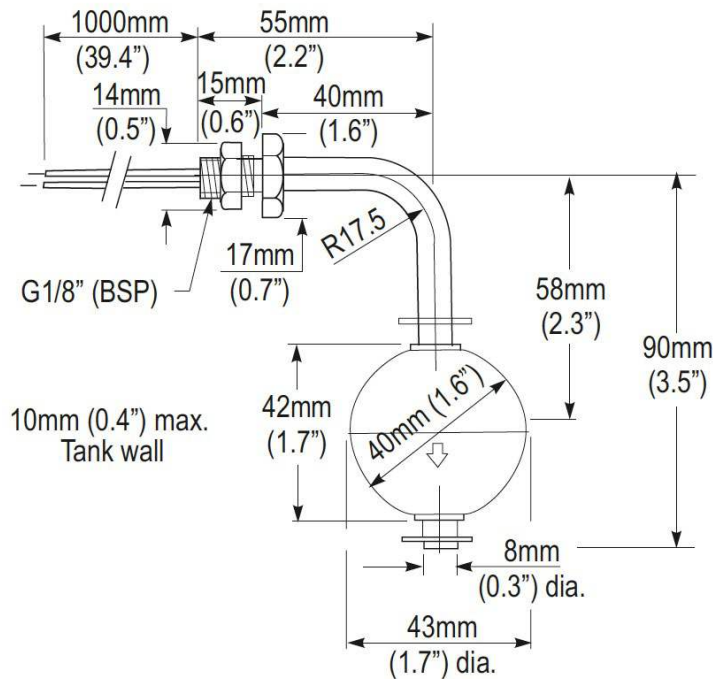

Made in the UK

Page 2

Sensata Technologies, Inc. ("Sensata") data sheets are solely intended to assist designers ("Buyers") who are developing systems that incorporate Sensata products (also referred to herein as "components"). Buyer understands and agrees that Buyer remains responsible for using its independent analysis, evaluation and judgment in designing Buyer's systems and products. Sensata data sheets have been created using standard laboratory conditions and engineering practices. Sensata has not conducted any testing other than that specifically described in the published documentation for a particular data sheet. Sensata may make corrections, enhancements, improvements and other changes to its data sheets or components without notice.

Buyers are authorized to use Sensata data sheets with the Sensata component(s) identified in each particular data sheet. HOWEVER, NO OTHER LICENSE, EXPRESS OR IMPLIED, BY ESTOPPEL OR OTHERWISE TO ANY OTHER SENSATA INTELLECTUAL PROPERTY RIGHT, AND NO LICENSE TO ANY THIRD PARTY TECHNOLOGY OR INTELLECTUAL PROPERTY RIGHT, IS GRANTED HEREIN. SENSATA DATA SHEETS ARE PROVIDED "AS IS". SENSATA MAKES NO WARRANTIES OR REPRESENTATIONS WITH REGARD TO THE DATA SHEETS OR USE OF THE DATA SHEETS, EXPRESS, IMPLIED OR STATUTORY, INCLUDING ACCURACY OR COMPLETENESS. SENSATA DISCLAIMS ANY WARRANTY OF TITLE AND ANY IMPLIED WARRANTIES OF MERCHANTABILITY, FITNESS FOR A PARTICULAR PURPOSE, QUIET ENJOYMENT, QUIET POSSESSION, AND NON-INFRINGEMENT OF ANY THIRD PARTY INTELLECTUAL PROPERTY RIGHTS WITH REGARD TO SENSATA DATA SHEETS OR USE THEREOF.

All products are sold subject to Sensata's terms and conditions of sale supplied at [www.sensata.com](http://www.sensata.com) SENSATA ASSUMES NO LIABILITY FOR APPLICATIONS ASSISTANCE OR THE DESIGN OF BUYERS' PRODUCTS. BUYER ACKNOWLEDGES AND AGREES THAT IT IS SOLELY RESPONSIBLE FOR COMPLIANCE WITH ALL LEGAL, REGULATORY AND SAFETY-RELATED REQUIREMENTS CONCERNING ITS PRODUCTS, AND ANY USE OF SENSATA COMPONENTS IN ITS APPLICATIONS, NOTWITHSTANDING ANY APPLICATIONS-RELATED INFORMATION OR SUPPORT THAT MAY BE PROVIDED BY SENSATA.

Mailing Address: Sensata Technologies, Inc., 529 Pleasant Street, Attleboro, MA 02703, USA.

## CONTACT US

+44 (0)1202 897969  
 c3w\_sales@sensata.com  
 Cynergy3 Components Ltd.  
 7 Cobham Road,  
 Ferndown Industrial Estate,  
 Wimborne, Dorset,  
 BH21 7PE, United Kingdom