

REVISIONS				
P	LTR	DESCRIPTION	DATE	DWN APVD
D		ECO-18-017215	03DEC2018	FL HL

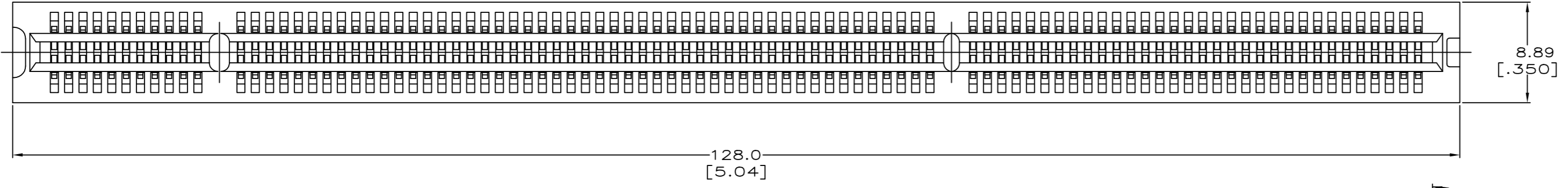

SEE SHEET 2 FOR NOTES

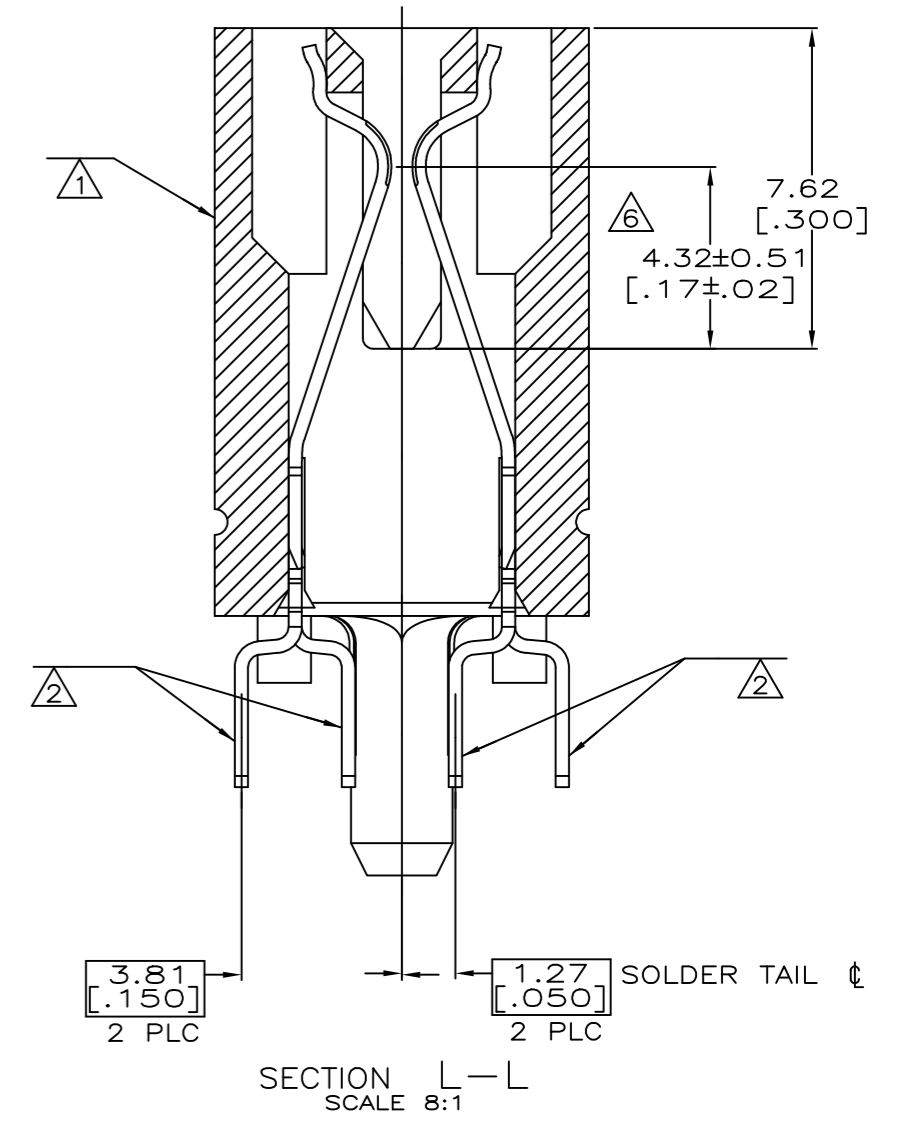
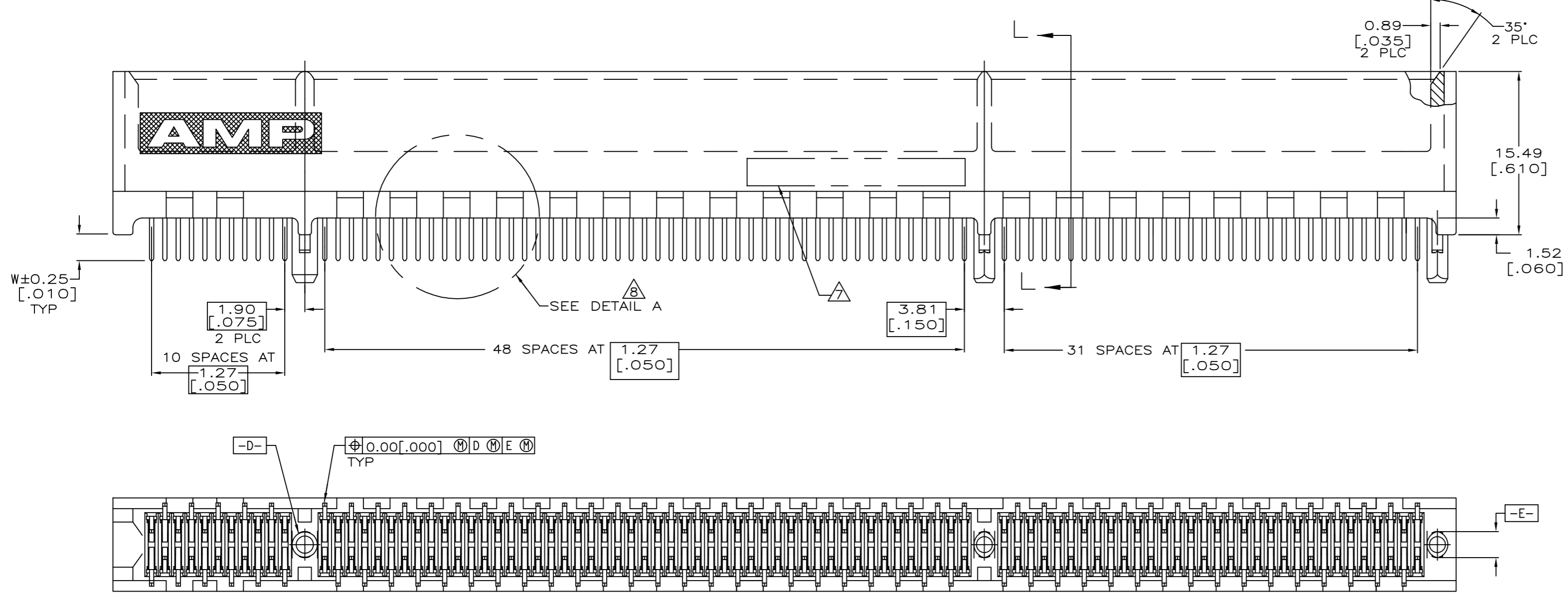

SEE SHEET 2 FOR HOLE PATTERN

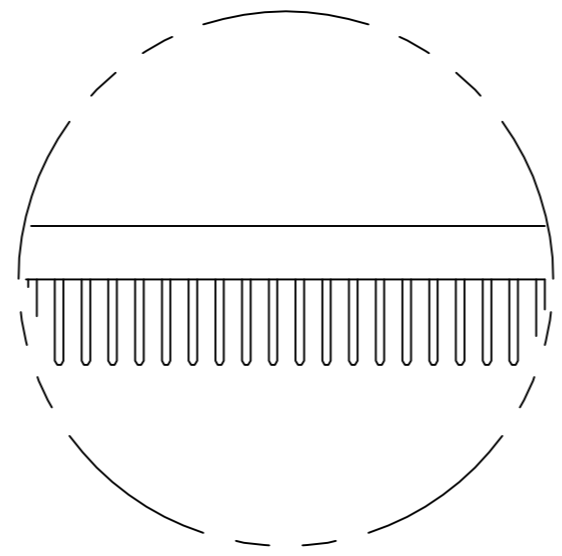

DETAIL A

3.56 [.140]	△	1-5145165-2
3.17 [.125]	△	5145165-8
2.54 [.100]	△	5145165-4
2.54 [.100]	△	5145165-2
2.54 [.100]	△	5145165-1

OBSOLETE

THIS DRAWING IS A CONTROLLED DOCUMENT.		DWN AL FRANTUM 04 FEB 05	TE Connectivity Ltd.	
DIMENSIONS: mm		CHK AL FRANTUM 04 FEB 05	CONNECTOR ASSEMBLY, 92 DUAL POSITION, .050 SERIES, STANDARD EDGE	
TOLERANCES UNLESS OTHERWISE SPECIFIED:		APVD -	NAME	
0 PLC ± -	1 PLC ± -	PRODUCT SPEC 108-14034		
2 PLC ± 0.25 [31]	3 PLC ± 0.13 [005]	APPLICATION SPEC 114-26012		
4 PLC ± -	ANGLES ± °	SIZE CAGE CODE DRAWING NO A1 00779 ©=5145165		
MATERIAL	FINISH	WEIGHT		RESTRICTED TO
△/△	△/△/△	CUSTOMER DRAWING		SCALE 4:1 SHEET 1 OF 2 REV D

REVISIONS				
P	LTR	DESCRIPTION	DATE	DWN APVD
-	-	SEE SHEET 1	-	-

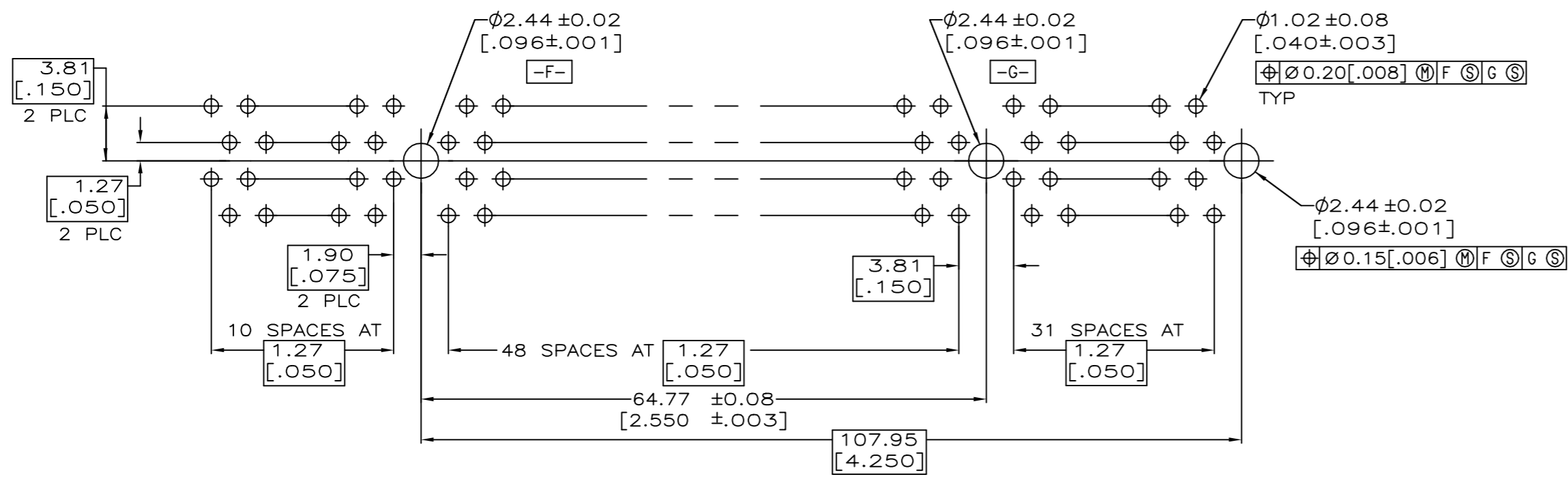

RECOMMENDED CONNECTOR MOUNTING HOLE PATTERN
(CONNECTOR SIDE SHOWN)

- 1 HOUSING: HIGH TEMPERATURE THERMOPLASTIC.
COLOR - NATURAL
- 2 CONTACT: PHOSPHOR BRONZE.
- 3 CONTACT FINISH: 0.00127[.000050] MIN NICKEL ALL OVER.
GOLD FLASH OVER NICKEL IN CONTACT AREA.
0.00254[.000100] MIN MATTE TIN OVER NICKEL ON SOLDER TAILS.
- 4 CONTACT FINISH: 0.00127[.000050] MIN NICKEL ALL OVER.
0.00038[.000015] GOLD OVER NICKEL IN CONTACT AREA.
0.00254[.000100] MIN MATTE TIN OVER NICKEL ON SOLDER TAILS.
- 5 CONTACT FINISH: 0.00127[.000050] MIN NICKEL ALL OVER.
0.00076[.000030] GOLD OVER NICKEL IN CONTACT AREA.
0.00254[.000100] MIN MATTE TIN OVER NICKEL ON SOLDER TAILS.
- 6 DISTANCE FROM CONTACT POINT TO BOTTOM OF CARD SLOT.
- 7 AMP PART NUMBER, DATE CODE AND CSA LOGO MARKED IN APPROXIMATE LOCATION SHOWN.
- 8 CORED OR SOLID SIDE WALLS ARE AT DISCRETION OF AMP INCORPORATED.

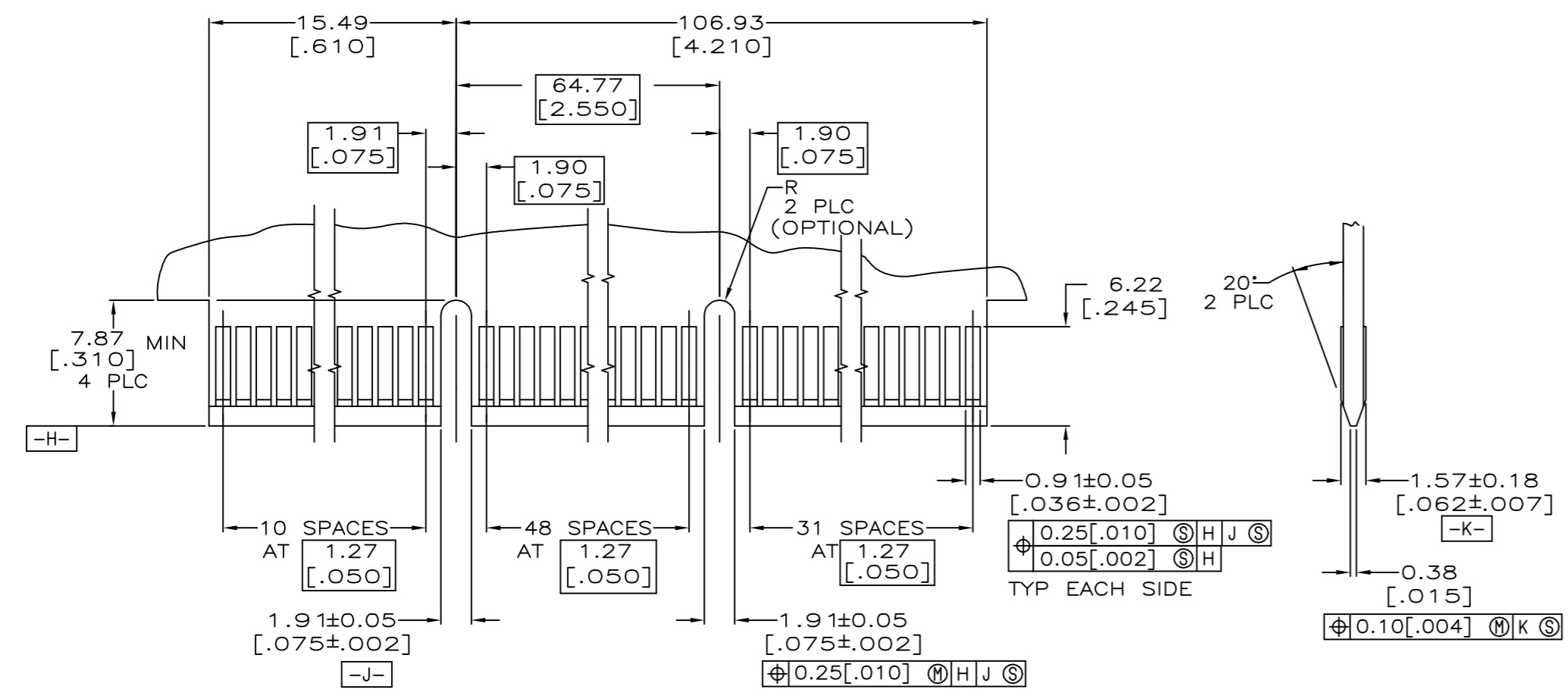

RECOMMENDED MATING BOARD EDGE CONFIGURATION

THIS DRAWING IS A CONTROLLED DOCUMENT.		DWN: AL FRANTUM 04 FEB 05	TE Connectivity Ltd.
		CHK: AL FRANTUM 04 FEB 05	
DIMENSIONS: mm		APVD: -	NAME: -
TOLERANCES UNLESS OTHERWISE SPECIFIED: 0 PLC ± - 1 PLC ± - 2 PLC ± 0.25 [01] 3 PLC ± 0.13 [005] 4 PLC ± - X ANGLES ± - X		PRODUCT SPEC: 108-14034	CONNECTOR ASSEMBLY, 92 DUAL POSITION, .050 SERIES, STANDARD EDGE
MATERIAL: -		FINISH: -	APPLICATION SPEC: 114-26012
		WEIGHT: -	SIZE: A1
		CUSTOMER DRAWING	CAGE CODE: 00779
		SCALE: 4:1	DRAWING NO: 5145165
		SHEET: 2 OF 2	REV: D