

Features and Benefits

- Absolute Rotary & Linear Position Sensor IC
- Robust Dual Mold Package (DMP) feat. 4 Decoupling Capacitors (ESD/EMC)
- Reliable NoPCB Module Integration
- Triaxis Hall Technology
- Simple Magnetic Design
- Programmable Transfer Characteristic (Multi-Points – Piece-Wise-Linear)
- Selectable Output Mode: Analog (Ratiometric) – Pulse Width Modulation (PWM)
- 12 bit Resolution - 10 bit Thermal Accuracy
- Open/Short Diagnostics
- On Board Diagnostics
- Over-Voltage Protection
- Under-Voltage Detection
- 48 bit ID Number option
- Automotive Temperature Range
- AEC-Q100 & AEC-Q200 Qualified
- DMP-4 RoHS Compliant

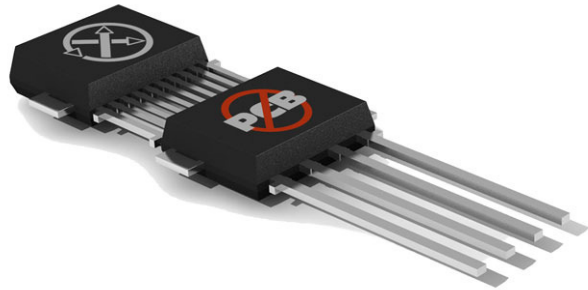

Applications

- Absolute Rotary Position Sensor
- Absolute Linear Position Sensor
- EGR Valve Position Sensor
- Turbo Actuator
- Throttle Position Sensor
- Clutch, Shift & Fork Position Sensor
- Ride Height Position Sensor
- Float Level Sensor

Ordering Information

Product Code	Temperature Code	Package Code	Option code	Packing form code
MLX90364	L	VS	ABB-100	RE
MLX90364	L	VS	ABB-100	TU
MLX90364	L	VS	ABB-101	RE
MLX90364	L	VS	ABB-103	RE
MLX90364	L	VS	ABB-200	RE
MLX90364	L	VS	ABB-200	TU
MLX90364	L	VS	ABB-201	RE
MLX90364	L	VS	ABB-203	RE
MLX90364	L	VS	ADB-100	RE
MLX90364	L	VS	ADB-100	TU
MLX90364	L	VS	ADB-101	RE
MLX90364	L	VS	ADB-103	RE
MLX90364	L	VS	ADB-200	RE
MLX90364	L	VS	ADB-200	TU
MLX90364	L	VS	ADB-201	RE
MLX90364	L	VS	ADB-203	RE

Legend:

Temperature Code: L for Temperature Range - 40°C to 150°C,

Package Code: VS for DMP-4

Option Code: **AAA-123:**

AAA: die version

1: IMC placement

23: Trim and form option:

- 00: Standard (straight leads) see section 20.1
- 01: Trim and Form STD1 2.54 see section 20.2
- 03: Trim and Form STD2 2.54 see section 20.3

Packing Form: RE for Reel (face-up)

TU for Tube

Ordering Example: MLX90364LVS-ADB-200-RE

1. Functional Diagram

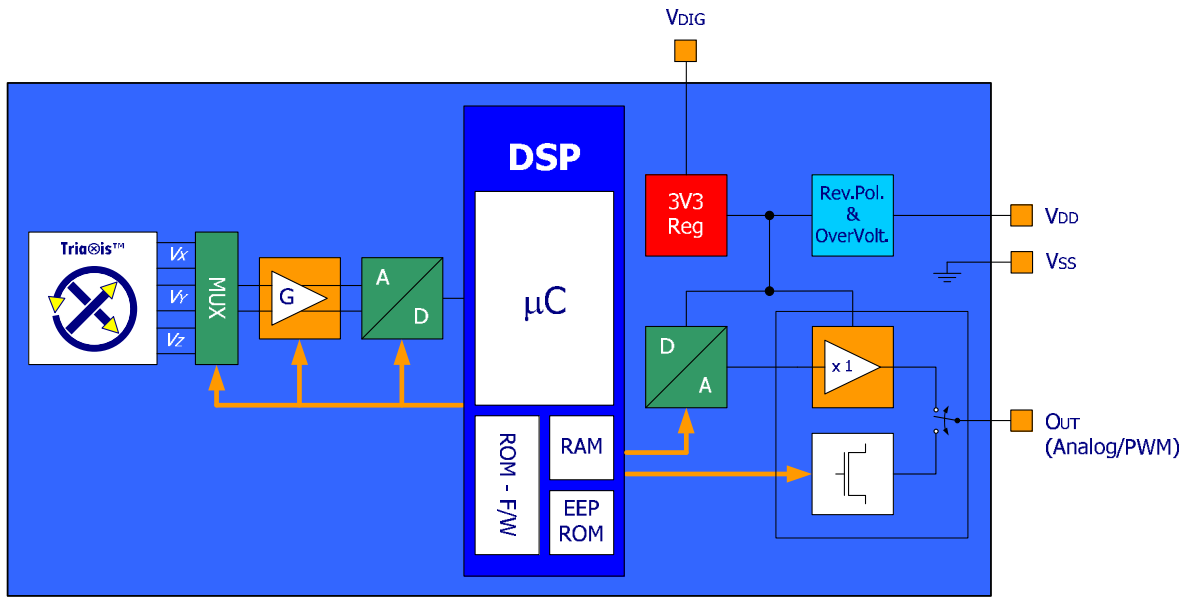

Figure 1 - MLX90364 Block Diagram

2. Description

The MLX90364 Triaxis® Position Sensor Assembly is a high accuracy linear and angular position sensor which eliminates need for inclusion of a printed circuit board (PCB) within sensing modules.

This device is based on a Dual Mold Package (DMP) construction, which integrates a Triaxis position sensing die together with the decoupling capacitors necessary to meet the strenuous ESD and EMC requirements. No PCB is needed.

The Triaxis position sensing die is nothing but the one used for the MLX90365 in conventional surface-mount packages (SOIC-8 – single die & TSSOP-16 – dual die).

The decoupling capacitors are 4 identical 100nF/X8R well suited for package integration and the target operating temperature range.

Similarly to other Triaxis products, the MLX90364 is sensitive to the flux density applied orthogonally and parallel to the IC surface i.e. the 3 components of the flux density applied to the IC (i.e. B_x , B_y and B_z).

This allows the MLX90364 with the correct magnetic circuit to decode the absolute position of any moving magnet (e.g. rotary position from 0 to 360 Degrees or linear displacement, stroke).

MLX90364 reports a programmable ratiometric analog output signal compatible with any resistive potentiometer or programmable linear Hall sensor. Through programming, the MLX90364 provides also a digital PWM (Pulse Width Modulation) output characteristic.

MLX90364 Triaxis® Position Sensor Assembly enables the realization of position sensor modules for which a PCB is no longer needed: this yield to an increase of the electrical, mechanical and environmental robustness of the final application.

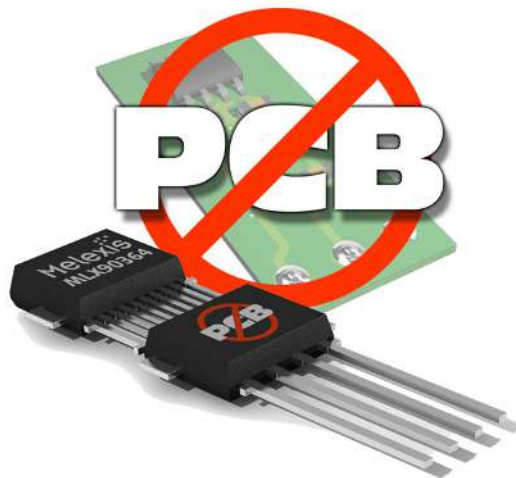

Figure 2 – NoPCB – MLX90364 makes conventional PCB redundant

TABLE of CONTENTS

FEATURES AND BENEFITS	1
APPLICATIONS.....	1
ORDERING INFORMATION.....	2
1. FUNCTIONAL DIAGRAM.....	3
2. DESCRIPTION.....	4
3. GLOSSARY OF TERMS – ABBREVIATIONS – ACRONYMS	7
4. PINOUT.....	7
5. ABSOLUTE MAXIMUM RATINGS	7
6. DESCRIPTION.....	8
7. MLX90364 ELECTRICAL SPECIFICATION.....	10
8. MLX90365 TIMING SPECIFICATION	12
9. MLX90364 PWM TIMING SPECIFICATION	12
10. MLX90364 ACCURACY SPECIFICATION	13
10.1. NORMAL MAGNETIC RANGE: $20\text{ MT} \leq B < 70\text{ MT}$	13
10.2. EXTENDED RANGE #1 : $15\text{ MT} \leq B < 20\text{ MT}$	14
10.3. EXTENDED RANGE #2: $10\text{ MT} \leq B < 15\text{ MT}$	14
11. MLX90364 PWM ACCURACY SPECIFICATION	15
12. MLX90364 MAGNETIC SPECIFICATION	16
13. MLX90364 CPU & MEMORY SPECIFICATION	16
14. MLX90364 END-USER PROGRAMMABLE ITEMS.....	17
15. DESCRIPTION OF END-USER PROGRAMMABLE ITEMS.....	18
15.1. OUTPUT MODE.....	18
15.1.1. <i>PWM Output Mode</i>	18
15.2. OUTPUT TRANSFER CHARACTERISTIC.....	19
15.2.1. <i>Enable scaling Parameter (only for LNR type 4 pts)</i>	19
15.2.2. <i>CLOCKWISE Parameter</i>	19
15.2.3. <i>Discontinuity Point (or Zero Degree Point)</i>	20
15.2.4. <i>4-Pts LNR Parameters</i>	20
15.2.5. <i>17-Pts LNR Parameters</i>	21
15.2.6. <i>CLAMPING Parameters</i>	22
15.3. IDENTIFICATION	22
15.4. SENSOR FRONT-END	22
15.4.1. <i>MAPXYZ</i>	22
15.4.2. <i>SMISM, k and SEL_k Parameters</i>	23
15.4.3. <i>GAINMIN and GAINMAX Parameters</i>	23
15.4.4. <i>GAINMIN and GAINMAX Parameters</i>	23
15.5. FILTER	23
15.5.1. <i>Hysteresis Filter</i>	23
15.5.2. <i>FIR Filters</i>	24
15.6. PROGRAMMABLE DIAGNOSTIC SETTINGS	25
15.6.1. <i>DIAG mode</i>	25

15.6.2.	DIAG Level.....	25
15.6.3.	Field Strength Diagnostic (Feature under development).....	26
15.6.4.	PWM Diagnostic	26
15.6.5.	Diagnostic Features	26
15.7.	EEPROM ENDURANCE	26
16.	MLX90364 SELF DIAGNOSTIC.....	27
17.	BUILT-IN CAPACITORS AND RECOMMENDED APPLICATION DIAGRAMS.....	29
18.	STANDARD INFORMATION REGARDING MANUFACTURABILITY OF MELEXIS PRODUCTS WITH DIFFERENT LEAD PRE-FORMING AND SOLDERING/WELDING PROCESSES	30
19.	ESD PRECAUTIONS.....	30
20.	PACKAGE INFORMATION.....	30
20.1.	DMP-4 – PACKAGE OUTLINE DIMENSIONS (POD) – STRAIGHT LEADS	30
20.2.	DMP-4 – PACKAGE OUTLINE DIMENSIONS (POD) – TRIMMED & FORMED LEADS [1].....	31
20.3.	DMP-4 – PACKAGE OUTLINE DIMENSIONS (POD) – TRIMMED & FORMED LEADS [2].....	32
20.4.	DMP-4 - PINOUT AND MARKING	32
20.5.	DMP-4 - SENSITIVE SPOT POSITIONING & SENSE DIRECTION	34
21.	DISCLAIMER.....	36

3. Glossary of Terms – Abbreviations – Acronyms

- Gauss (G), Tesla (T): Units for the magnetic flux density – 1 mT = 10 G
- TC: **T**emperature **C**oefficient (in ppm/Deg.C.)
- NC: **N**ot **C**onnected
- PWM: **P**ulse **W**idth **M**odulation
- %DC: **D**uty **C**ycle of the output signal i.e. $T_{ON} / (T_{ON} + T_{OFF})$
- ADC: **A**nalog-to-**D**igital **C**onverter
- DAC: **D**igital-to-**A**nalog **C**onverter
- LSB: **L**east **S**ignificant **B**it
- MSB: **M**ost **S**ignificant **B**it
- DNL: **D**ifferential **N**on-**L**inearity
- INL: **I**ntegral **N**on-**L**inearity
- RISC: **R**educed **I**nstruction **S**et **C**omputer
- ASP: **A**nalog **S**ignal **P**rocessing
- DSP: **D**igital **S**ignal **P**rocessing
- CoRDIC: **C**oordinate **R**otation **D**igital **C**omputer (i.e. iterative rectangular-to-polar transform)
- EMC: **E**lectro-**M**agnetic **C**ompatibility
- ALS: **A**nalog **L**ow **S**peed
- AHS: **A**nalog **H**igh **S**peed
- DLS: **D**igital **L**ow **S**peed
- DHS: **D**igital **H**igh **S**peed
- DMP: **D**ual **M**old **P**ackage

4. Pinout

Pin #	
1	VSS (Ground)
2	VDD
3	OUT
4	VSS (Ground)

5. Absolute Maximum Ratings

Parameter	Value
Supply Voltage, VDD (overvoltage)	+ 24 V
Reverse Voltage Protection	- 12 V (breakdown at -14 V)
Positive Output Voltage	+ 18 V (breakdown at 24 V)
Output Current (I _{OUT})	+ 30 mA (in breakdown)
Reverse Output Voltage	- 0.3 V
Reverse Output Current	- 50 mA (in breakdown)
Operating Ambient Temperature Range, T _A	- 40°C ... + 150°C
Storage Temperature Range, T _S	- 40°C ... + 150°C
Magnetic Flux Density	± 1 T

Exceeding the absolute maximum ratings may cause permanent damage. Exposure to absolute maximum rated conditions for extended periods may affect device reliability.

6. Description

As described on the block diagram the three vector components of the magnetic flux density (B_x , B_y and B_z) applied to the IC are sensed through the sensor front-end. The respective Hall signals (V_x , V_y and V_z) are generated at the Hall plates and amplified.

The analog signal processing is based on a fully differential analog chain featuring the classic offset cancellation technique (Hall plate 2-Phases spinning and chopper-stabilized amplifier).

The conditioned analog signals are converted through an ADC (15 bits) and provided to a DSP block for further processing. The DSP stage is based on a 16 bit RISC micro-controller whose primary function is the extraction of the position from two (out of three) raw signals (after so-called front-end compensation steps) through the following function:

$$\alpha = \angle(V_1, k \cdot V_2)$$

where α is the magnetic angle $\angle(B_1, B_2)$, $V_1 = V_x$ or V_y or V_z , $V_2 = V_x$ or V_y or V_z and k is a programmable factor to match the amplitude of V_1 and $k \cdot V_2$.

The DSP functionality is governed by the micro-code (firmware – F/W) of the micro-controller which is stored into the ROM (mask programmable). In addition to the magnetic angle extraction, the F/W controls the whole analog chain, the output transfer characteristic, the output protocol, the programming/calibration and also the self-diagnostic modes.

The magnetic angular information is intrinsically self-compensated vs. flux density variations. This feature allows therefore an improved thermal accuracy vs position sensor based on conventional linear Hall sensors.

In addition to the improved thermal accuracy, the realized position sensor features excellent linearity performances taking into account typical manufacturing tolerances (e.g. relative placement between the Hall IC and the magnet).

Once the position (angular or linear stroke) information is computed, it is further conditioned (mapped) vs. the target transfer characteristic and it is provided at the output(s) as either a ratiometric analog output level through a 12 bit DAC followed by a buffer or a digital PWM output.

For instance, the analog output can be programmed for offset, gain and clamping to meet any rotary position sensor output transfer characteristic:

$$\begin{aligned} V_{out}(\alpha) &= \text{ClampLo} && \text{for } \alpha \leq \alpha_{min} \\ V_{out}(\alpha) &= V_{offset} + \text{Gain} \times \alpha && \text{for } \alpha_{min} \leq \alpha \leq \alpha_{max} \\ V_{out}(\alpha) &= \text{ClampHi} && \text{for } \alpha \geq \alpha_{max} \end{aligned}$$

where V_{offset} , Gain , ClampLo and ClampHi are the main adjustable parameters for the end-user.

The linear part of the transfer curve can be adjusted through a multi-point calibration:

This back-end step consists into either

- up to 4 arbitrary points (5 segments + clamping levels) calibration or
- a Piece-Wise-Linear (PWL) output transfer characteristics - 17 equidistant points w/ programmable origin over 16 different angle ranges from 65 to 360 degrees.



MLX90364AxB

*Triaxis® Position
Sensor Assembly*

The calibration parameters are stored in EEPROM featuring a Hamming Error Correction Coding (ECC).

The programming steps do not require any dedicated pins. The operation is done using the supply and output nodes of the IC. The programming of the MLX90364 is handled at both engineering lab and production line levels by the Melexis Programming Unit PTC-04 with the dedicated MLX90364 daughterboard and software tools (DLL – User Interface).

7. MLX90364 Electrical Specification

DC Operating Parameters at VDD = 5V (unless otherwise specified) and for TA as specified by the Temperature suffix L.

Parameter	Symbol	Test Conditions	Min	Typ	Max	Units
Nominal Supply Voltage	VDD		4.5	5	5.5	V
Supply Current	I _{dd}				10	mA
Isurge Current ⁽¹⁾	I _{surge}				20	mA
Power-On reset (rising)	HPOR_LH	Refer to internal voltage Vdig	2	2.25	2.5	V
Power-On reset Hysteresis	HPOR_Hyst		50		200	mV
Start-up Level (rising)	MT4V LH		3.8	4.0	4.2	V
Start-up Hysteresis	MT4V Hyst		50		200	mV
PTC Entry Level (rising)	MT7V_LH		5.8	6.2	6.6	V
PTC Entry Level Hysteresis	MT7V_Hyst		50		200	mV
Output Short Circuit Current	I _{short}	Vout = 0 V			15	mA
		Vout = 5 V			15	mA
		Vout = 18 V (TA = 25°C)			18	mA
Output Load	RL	Pull-down to Ground	4.7	10	∞	kΩ
		Pull-up to 5V	4.7	10	∞	kΩ
Analog Saturation Output Level	Vsat_lo	Pull-up load RL ≥ 10 kΩ to 5 V Pull-up load RL ≥ 5 kΩ to 18V		0.5 2	2 3	%VDD
	Vsat_hi	Pull-down load RL ≥ 5 kΩ Pull-down load RL ≥ 10 kΩ	94 96	96 98		%VDD
Active Diagnostic Output Level	Diag_lo	Pull-up load RL ≥ 10 kΩ to 5 V Pull-up load RL ≥ 5 kΩ to 18V		0.5 2	2 3	%VDD
	Diag_hi	Pull-down load RL ≥ 5 kΩ Pull-down load RL ≥ 10 kΩ	94 96	96 98		%VDD
Passive Diagnostic Output Level (Broken Track Diagnostic) ⁽²⁾	BVssPD	Broken VSS & Pull-down load RL ≥ 10 kΩ	97.5			%VDD
	BVssPU	Broken VSS & Pull-up load RL ≥ 1kΩ	99.5	100		%VDD
	BVDDPD	Broken VDD & Pull-down load RL ≥ 1kΩ		0	0.5	%VDD
	BVDDPU	Broken VDD & Pull-up load RL ≥ 5kΩ			2	%VDD
Clamped Output Level	Clamp_lo	Programmable	0		100	%VDD ⁽³⁾
	Clamp_hi	Programmable	0		100	%VDD ⁽³⁾

¹ The specified value is valid during early start-up time only; the current might dynamically exceed the specified value, shortly, during the Start-up phase.

² For detailed information, see also section 1.5

³ Clamping levels need to be considered vs the saturation of the output stage (see Vsat_lo and Vsat_hi)

As an illustration of the previous table, the MLX90364 fits the typical classification of the output span described on the Figure 4.

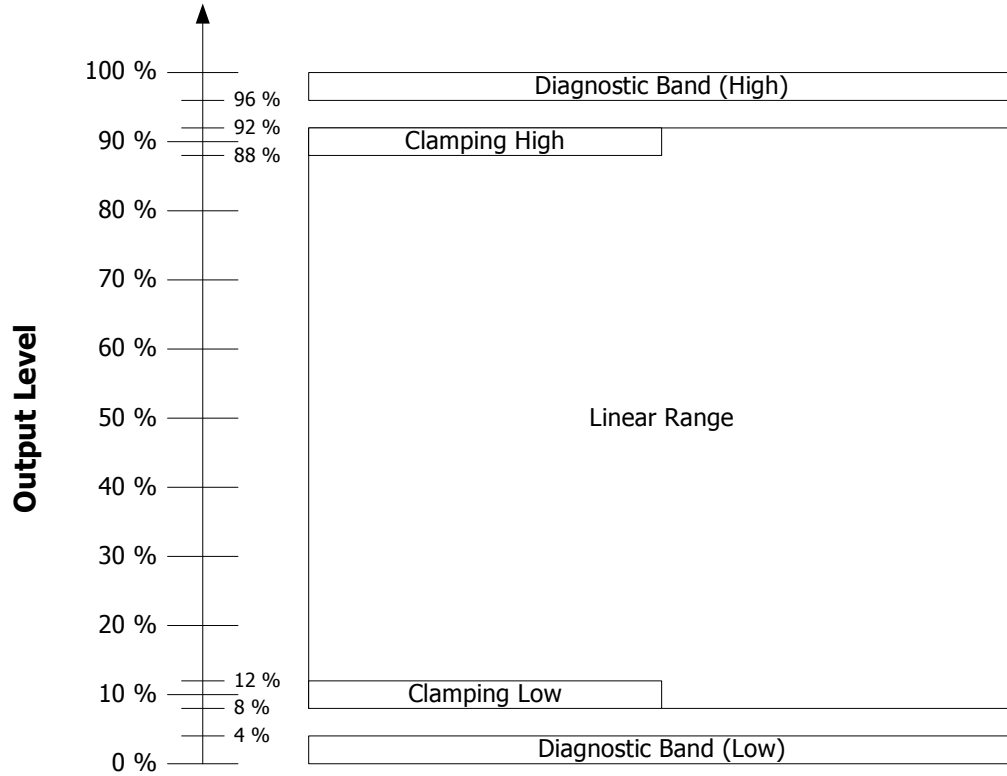

Figure 4 – Example of Output Span Classification for typical application.

8. MLX90365 Timing Specification

DC Operating Parameters at VDD = 5V (unless otherwise specified) and for T_A as specified by the Temperature suffix L.

Parameter	Symbol	Test Conditions	Min	Typ	Max	Units
Main Clock Frequency	Ck	All contributors included thermal drift	12.6	13.3	14	MHz
Main Clock Frequency Thermal Drift	$\Delta^T\text{Ck}$				$\pm 3\%$	Ck _{NOM}
Refresh Rate			281	290	299	μs
Step Response Time	Ts	Filter=0 ⁽⁴⁾	844	870	896	μs
		Filter=1	1125	1160	1195	
		Filter=2	1407	1450	1494	
Watchdog	Twd		114.5	118	121.5	ms
Start-up Cycle	Tsu	Analog OUT Slew-rate excluded			5	ms
Analog OUT Slew-rate			25	37		V/ms

9. MLX90364 PWM Timing Specification

DC Operating Parameters at VDD = VPU = 5V (unless otherwise specified) and for T_A as specified by the Temperature suffix L.

Parameter	Symbol	Test Conditions	Min	Typ	Max	Units
Digital Output Rise Time		LOW SIDE DRIVER – Mode 5 R _L = 1 k Ω PU		80	130	μs
		PUSH-PULL – Mode 7 R _L = 1 k Ω PU		27	50	μs
Digital Output Fall Time		LOW SIDE DRIVER – Mode 5 R _L = 1 k Ω PU		27	50	μs
		PUSH-PULL – Mode 7 R _L = 1 k Ω PU		27	50	μs

⁴ See section 15 for details concerning Filter parameter

10. MLX90364 Accuracy Specification

10.1. Normal Magnetic range: $20\text{ mT} \leq B < 70\text{ mT}$

DC Operating Parameters at $V_{DD} = 5V$ (unless otherwise specified) and for T_A as specified by the Temperature suffix L.

Parameter	Symbol	Test Conditions	Min	Typ	Max	Units
ADC Resolution on the raw signals sine and cosine ⁵⁾	R_{ADC}			15		bits
Thermal Offset Drift #1 ⁶⁾ at the DSP input (excl. DAC and output stage)			-90		+90	LSB ₁₅
Thermal Offset Drift #2 (DAC and Output Stage)			-0.2		+0.2	%VDD
Thermal Drift of Sensitivity Mismatch ⁷⁾		XY axis	-0.5		+0.5	%
		XZ (YZ) axis	-1		+1	%
Magnetic Angle phase error		$T_A = 25^\circ\text{C} - \text{XY axis}$	-0.3		0.3	Deg.
		$T_A = 25^\circ\text{C} - \text{XZ axis}$	-2		2	
		$T_A = 25^\circ\text{C} - \text{YZ axis}$	-10		10	
Thermal Drift of Magnetic Angle phase error		XY axis, XZ (YZ) axis		0.01		Deg.
XY – Intrinsic Linearity Error ⁸⁾	Le	$T_A = 25^\circ\text{C} - \text{factory trim. "SMISM"}$	-1		1	Deg
XZ - Intrinsic Lin. Error ⁸⁾	Le	$T_A = 25^\circ\text{C} - \text{"k" trimmed for XZ}$	-2.5	± 1.25	2.5	Deg
YZ - Intrinsic Lin. Error ⁸⁾	Le	$T_A = 25^\circ\text{C} - \text{"k" trimmed for YZ}$	-10	± 2.5	+10	Deg
Analog Output Resolution	R_{DAC}	12b DAC (Theoretical, Noise free)		0.025		%VDD/LSB ₁₂
		INL (before EOL calibration)	-4		+4	LSB ₁₂
		DNL	0.05	1	3	LSB ₁₂
Output stage Noise		Clamped Output		0.05	0.075	%VDD
Noise pk-pk ⁹⁾		Slow mode, Filter=2		0.10	0.2	Deg
		Fast mode, Filter=0		0.15	0.2	Deg
Ratiometry Error (Analog output only)		$4.5V \leq V_{DD} \leq 5.5V$	-0.05		+0.05	%VDD
		$LT4V \leq V_{DD} \leq MT7V$	-0.1		+0.1	%VDD

⁵ 16 bits corresponds to 15 bits + sign. Internal computation is performed using 16 bits.

⁶ For instance, in case of a rotary position sensor application, Thermal Offset Drift #1 equal $\pm 60\text{LSB}_{15}$ yields to max. ± 0.3 Deg. angular error for the computed angular information (output of the DSP). This is only valid if $k = 1$. "MLX90364 Front-End Application Note" will be released for more details.

⁷ For instance, in case of a rotary position sensor application, Thermal Drift of Sensitivity Mismatch equal $\pm 0.5\%$ yields to max. ± 0.15 Deg. angular error for the computed angular information (output of the DSP). See "MLX90364 Front-End Application Note" for more details.

⁸ The Intrinsic Linearity Error refers to the IC itself (offset, sensitivity mismatch, orthogonality) taking into account an ideal rotating field for B_x and B_y . Once associated to a practical magnetic construction and the associated mechanical and magnetic tolerances, the output linearity error increases. However, it can be improved with the multi-point end-user calibration. The intrinsic Linearity Error for Magnetic angle $\angle XZ$ and $\angle YZ$ can be reduced through the programming of the k factor.

⁹ Noise pk-pk (peak-to-peak) is here intended as 6 times the Noise standard Deviation. The application diagram used is described in the recommended wiring. For detailed information, refer to section Filter in application mode (Section 15.5).

10.2. Extended Range #1 : $15\text{ mT} \leq B < 20\text{ mT}$

DC Operating Parameters at VDD = 5V (unless otherwise specified) and for T_A as specified by the Temperature suffix L.

Parameter	Symbol	Test Conditions	Min	Typ	Max	Units
Offset on Raw Signals X,Y,Z	X0,Y0,Z0	T _A = 25 Deg.C.	-120		+120	bits
Thermal Offset Drift #1 at the DSP input (excl. DAC and output stage)			-180		+180	LSB ₁₅
Noise pk-pk		Slow mode, Filter=2 Fast mode, Filter=0			60 75	LSB ₁₅ LSB ₁₅

In case of the use of the MLX90364 in those extended ranges, Melexis recommends to validate the headroom of the internal diagnostic and if necessary to disable the diagnostic mode related to the amplitude of the flux strength and/or amplification factor of the device.

10.3. Extended Range #2: $10\text{ mT} \leq B < 15\text{ mT}$

DC Operating Parameters at VDD = 5V (unless otherwise specified) and for T_A as specified by the Temperature suffix L.

Parameter	Symbol	Test Conditions	Min	Typ	Max	Units
Offset on Raw Signals X,Y,Z	X0,Y0,Z0	T _A = 25 Deg.C.	-180		+180	bits
Thermal Offset Drift #1 at the DSP input (excl. DAC and output stage)			-270		+270	LSB ₁₅
Noise pk-pk		Slow mode, Filter=2 Fast mode, Filter=0			90 112	LSB ₁₅ LSB ₁₅

In case of the use of the MLX90364 in those extended ranges, Melexis recommends to validate the headroom of the internal diagnostic and if necessary to disable the diagnostic mode related to the amplitude of the flux strength and/or amplification factor of the device.

11. MLX90364 PWM Accuracy Specification

DC Operating Parameters at VDD = 5V +/- 10 % (unless otherwise specified) and for T_A as specified by the Temperature suffix L.

Parameter	Symbol	Test Conditions	Min	Typ	Max	Units
PWM Output Resolution	R _{PWM}	12 bits		0.025		%DC/LSB
PWM % DC Jitter ⁽¹⁰⁾	J _{DC}	LOW SIDE DRIVER – Mode5 200Hz, R _L = 1 kΩ PU PUSH-PULL – Mode7 200Hz, R _L = 1 kΩ PU		±0.015	±0.075 ±0.075	%DC
PWM Freq Jitter ⁽¹¹⁾	J _{PWM}	LOW SIDE DRIVER – Mode5 100-1000 Hz, R _L = 1 kΩ PU PUSH-PULL – Mode7 100-1000 Hz, R _L = 1 kΩ PU		±0.05 ±0.05	±0.2 ±0.2	Hz
PWM % DC thermal drift		LOW SIDE DRIVER – Mode5 100Hz, R _L = 1 kΩ PU 200Hz, R _L = 1 kΩ PU PUSH-PULL – Mode7 100Hz, R _L = 1 kΩ PU 200Hz, R _L = 1 kΩ PU		0.02 0.02 0.02 0.02	0.03 0.03 0.03 0.03	%DC

Parameter	Symbol	Test Conditions
PWM TON, Tperiod	T _{ON} T _{PWM}	Trigger level = 50 % V _{Push-pull}
Rise time Fall time		10% and 90% of amplitude
Jitter	J on J period	± 3 σ for 1000 successive acquisitions
Duty Cycle	% DC	T _{on} / T _{Period}

¹⁰ Jitter is defined by ± 3 σ for 1000 successive acquisitions with clamped output.

¹¹ Jitter is defined by ± 3 σ for 1000 successive acquisitions with clamped output.

12. MLX90364 Magnetic Specification

DC Operating Parameters at VDD = 5V (unless otherwise specified) and for TA as specified by the Temperature suffix L.

Parameter	Symbol	Test Conditions	Min	Typ	Max	Units
Magnetic Flux Density	B _x , B _y ⁽¹²⁾		20		70 ⁽¹³⁾	mT
Magnetic Flux Density	B _z				126	mT
Magnetic Field Norm	Norm	$\sqrt{B_x^2 + B_y^2 + (B_z/\text{GainIMC})^2}$	20 ⁽¹⁴⁾			mT
IMC Gain ⁽¹⁵⁾	GainIMC		1.2	1.5	1.8	
Magnet Temperature Coefficient	TCm		-2400		0	ppm/°C

13. MLX90364 CPU & Memory Specification

The DSP is based on a 16 bit RISC μ Controller. This CPU provides 2.5 Mips while running at 10 MHz.

Parameter	Symbol	Test Conditions	Min	Typ	Max	Units
ROM				10		kB
RAM				384		B
EEPROM				128		B

¹² The condition must be fulfilled for at least one field BX, or BY.

¹³ Above 70 mT, the IMC starts saturating yielding to an increase of the linearity error. Below 20 mT, the performances slightly degrade due to a reduction of the signal-to-noise ratio, signal-to-offset ratio.

¹⁴ Below 20 mT, the performances slightly degrade due to a reduction of the signal-to-noise ratio, signal-to-offset ratio.

¹⁵ This is the magnetic gain linked to the Integrated Magneto Concentrator structure. It applies to BX and BY and not to BZ. This is the overall variation. Within one lot, the part to part variation is typically $\pm 10\%$ versus the average value of the IMC gain of that lot.

14. MLX90364 End-User Programmable Items

Parameter	Comments	Default Values		
		Standard	PPAR	# bit
OUT mode	Define the output stage mode	1	1	3
DIAG mode	Diagnostic mode	7	7	3
DIAG Level	Diagnostic Level	0	0	1
MAPXYZ	Mapping fields for output angle	0	0	2
CLAMP_HIGH	Clamping High (50%)	50%	10%	16
CLAMP_LOW	Clamping Low (50%)	50%	90%	16
FILTER	Filter mode selection	0	1	2
SMISM	Sensitivity mismatch factor X,Y	MLX	MLX	15
k	Sensitivity mismatch factor X (Y) , Z	MLX	N/A	15
SEL_k	Affected signal component by k: B1 or B2 (in combination of MAPXYZ)	0	0	1
GAINMIN	Low threshold for virtual gain	01h	01h	8
GAINMAX	High threshold for virtual gain	28h	28h	8
GAINSATURATION	Gain Saturates on GAINMIX and GAINMAX	0h	0h	1
FIELDTHRESH	Field limit under which a fault is reported	00FFh	00FFh	16
PWM	PWM function	0h	N/A	1
PWMPOL	PWM polarity	0h	N/A	1
PWMT	PWM Frequency (trimmed at 200Hz)	MLX	N/A	8
DC_FAULT	PWM Duty Cycle if Fault	1h	N/A	8
DC_FTL	PWM Duty Cycle if Field Strength Too Low	1h	N/A	8
DC_WEAK	PWM Duty Cycle if Weak Magnet	1h	N/A	8
WEAKMAGTHRESH	Weak Magnet threshold Byte (1lsb = 1mT)	0h	N/A	8
DP	Discontinuity point	0h	0h	15
CW	Clock Wise	0h	0h	1
FHYST	Hysteresis filter	0h	0h	8
MELEXISID1	Melexis identification reference	MLX	MLX	16
MELEXISID2	Melexis identification reference	MLX	MLX	16
MELEXISID3	Melexis identification reference	MLX	MLX	16
4POINTS	Selection of correction method 4 or 16 pts	1h	1h	1
LNR_S0	4pts – Initial Slope	0 %/deg	0 %/deg	16
LNR_A_X	4pts – AX Coordinate	0 deg	0 deg	16
LNR_A_Y	4pts – AY Coordinate	10 %	10 %	16
LNR_A_S	4pts – AS Coordinate	0.22%/deg	0.22%/deg	16
LNR_B_X	4pts – BX Coordinate	360 deg	360 deg	16
LNR_B_Y	4pts – BY Coordinate	100%	100%	16
LNR_B_S	4pts – BS Coordinate	0 %/deg	0 %/deg	16
LNR_C_X	4pts – CX Coordinate	360 deg	360 deg	16
LNR_C_Y	4pts – CY Coordinate	100%	100%	16
LNR_C_S	4pts – CS Coordinate	0 %/deg	0 %/deg	16
LNR_D_X	4pts – DX Coordinate	360 deg	360 deg	16
LNR_D_Y	4pts – DY Coordinate	100%	100%	16
LNR_D_S	4pts – DS Coordinate	0 %/deg	0 %/deg	16
W	17pts – Output angle range	0h	N/A	4
CUSTOMERID1	Cust. id reference	Bin 1	Bin 1	16

CUSTOMERID2	Cust. id reference	202h	3h	16
CUSTOMERID3	Cust. id reference	0h	0h	16
LNR_Yn	17pts – Y-coordinate point n (n = 2,1,2 ... 16)	N/A	N/A	16
DIAG Settings	16 Bit Diagnostics enabling	FDFh	4080h	16
CRC_DISABLE	Enable EERPOM CRC check (3131h= disable)	0h	0h	16

15. Description of End-User Programmable Items

15.1. Output Mode

The MLX90364 output type is defined by the Output Mode parameter.

Output mode[2:0]	Type	Descriptions	Comments
0	Disable	Output HiZ	Not recommended
1	Analog	Analog Rail-to-Rail	Analog
5	Digital	open drain NMOS	PWM
6	Digital	open drain PMOS	PWM
7	Digital	Push-Pull	PWM

15.1.1. PWM Output Mode

If PWM output mode is selected, the output signal is a digital signal with Pulse Width Modulation (PWM). The PWM polarity is selected by the PWMPOL parameter:

- PWMPOL = 0 for a low level at 100%
- PWMPOL = 1 for a high level at 100%
-

The PWM frequency is selected by the PWMT parameter. The following table provides typical code for different target PWM frequency and for both low and high speed modes.

PWW F (Hz)	PWMT (LSB) @12.5MHz	PWM res. (us)	PWM res. (%)	PWM res. (bit)
125	33333	0.240	0.003	15.0
250	16666	0.240	0.006	14.0
500	8333	0.240	0.012	13.0

Notes:

- A more accurate trimming can be performed to take into account initial tolerance of the main clock.
- The PWM frequency is subjected to the same tolerances as the main clock (see $\Delta^T Ck$).

15.2. Output Transfer Characteristic

There are 2 different possibilities to define the transfer function (LNR):

- With 4 arbitrary points (defined on X and Y coordinates) and 5 slopes
- With 17 equidistant points for which only the Y coordinates are defined.

Parameter	LNR type	Value	Unit
COUNTERCLOCKWISE	Both	0 → CounterClockWise 1 → ClockWise	LSB
DP	Both	0 ... 359.9999	deg
LNR_A_X LNR_B_X LNR_C_X LNR_D_X	Only 4 pts	0 ... 359.9999	deg
LNR_A_Y LNR_B_Y LNR_C_Y LNR_D_Y	Only 4 pts	0 ... 100	%
LNR_S0 LNR_A_S LNR_B_S	Only 4 pts	0 ... 17	%/deg
LNR_C_S LNR_D_S	Only 4 pts	-17 ... 0 ... 17	%/deg
LNR_Y0 LNR_Y1 ... LNR_Y16	Only 16 pts	-50 ... + 150	%
W	Only 16 pts	65.5 ... 360	Deg
CLAMP_LOW	Both	0 ... 100	%
CLAMP_HIGH	Both	0 ... 100	%

15.2.1. Enable scaling Parameter (only for LNR type 4 pts)

This parameter enables to scale LNR_x_Y from -50% - 150% according to the following formula

$$(\text{Scaled Out})\%V_{DD} = 2 \times \text{Out}\%V_{DD} - 50\%$$

15.2.2. CLOCKWISE Parameter

The CLOCKWISE parameter defines the magnet rotation direction.

- CCW is defined by the 1-2-3-4 pin order direction for the Dual Mold Package.
- CW is defined by the reverse direction: 4-3-2-1 pin order direction for the Dual Mold Package.

Refer to the drawing in the sensitive spot positioning sections (Section 20.5)

15.2.3. Discontinuity Point (or Zero Degree Point)

The Discontinuity Point defines the 0° point on the circle. The discontinuity point places the origin at any location of the trigonometric circle. The DP is used as reference for all the angular measurements.

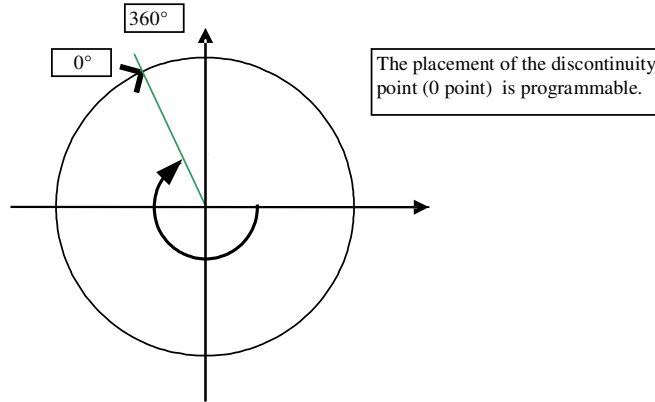

Figure 5 - Discontinuity Point Positioning

15.2.4. 4-Pts LNR Parameters

The LNR parameters, together with the clamping values, fully define the relation (the transfer function) between the digital angle and the output signal.

The shape of the MLX90364 transfer function from the digital angle value to the output voltage is described by the drawing below. Six segments can be programmed but the clamping levels are necessarily flat.

Two, three, or even six calibration points are then available, reducing the overall non-linearity of the IC by almost an order of magnitude each time. Three or six calibration point will be preferred by customers looking for excellent non-linearity figures. Two-point calibrations will be preferred by customers looking for a cheaper calibration set-up and shorter calibration time.

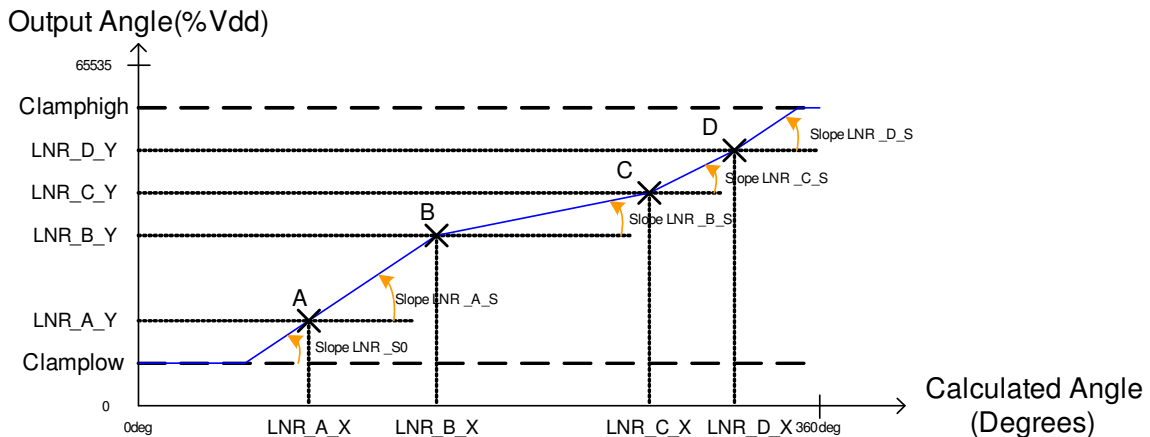

Figure 6

15.2.5. 17-Pts LNR Parameters

The LNR parameters, together with the clamping values, fully define the relation (the transfer function) between the digital angle and the output signal.

The shape of the MLX90364 transfer function from the digital angle value to the output voltage is described by the drawing below. In the 16-Pts mode, the output transfer characteristic is Piece-Wise-Linear (PWL).

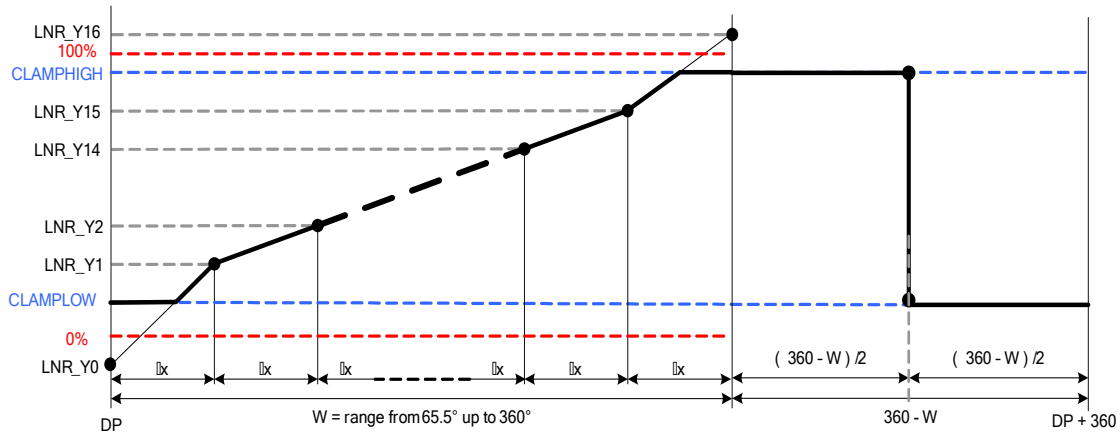

Figure 9 - Input range from 65.5° up to 360°

All the Y-coordinates can be programmed from -50% up to +150% to allow clamping in the middle of one segment (like on the figure), but the output value is limited to CLAMPLOW and CLAMPHIGH values.

Between two consecutive points, the output characteristic is interpolated.

The parameter W determines the input range on which the 17 points (16 segments) are uniformly spread:

W	Range	Δx
0 (0000b)	360.0deg	22.5deg
1	320.0deg	20.0deg
2	288.0deg	18.0deg
3	261.8deg	16.4deg
4	240.0deg	15.0deg
5	221.5deg	13.8deg
6	205.7deg	12.9deg
7	192.0deg	12.0deg

W	Range	Δx
8	180.0deg	11.3deg
9	144.0deg	9.0deg
10	120.0deg	7.5deg
11	102.9deg	6.4deg
12	90.0deg	5.6deg
13	80.0deg	5.0deg
14	72.0deg	4.5deg
15 (1111b)	65.5deg	4.1deg

Outside of the selected range, the output will remain in clamping levels.

15.2.6. CLAMPING Parameters

The clamping levels are two independent values to limit the output voltage range. The CLAMPLOW parameter adjusts the minimum output voltage level. The CLAMPHIGH parameter sets the maximum output voltage level. Both parameters have 16 bits of adjustment and are available for both LNR modes. In analog mode, the resolution will be limited by the D/A converter (12 bits) to 0.024%VDD. In PWM mode, the resolution will be 0.024%DC.

15.3. Identification

Parameter	Value
MELEXISID1	0 ... 65535
MELEXISID2	0 ... 65535
MELEXISID3	0 ... 65535
CUSTOMERID1	0 ... 65535
CUSTOMERID2	0 ... 65535
CUSTOMERID3	0 ... 65535

Identification number: 48 bits (3 words) freely useable by Customer for traceability purpose.

15.4. Sensor Front-End

Parameter	Value
MAPXYZ	0 .. 3
SMISM	0 .. 32768
k	0 .. 32768
SEL_k	0 or 1
GAINMIN	0 ... 41
GAINMAX	0 ... 41
GAINSATURATION	0.. 1

15.4.1. MAPXYZ

The MAPXYZ parameter defines which fields are used to calculate the angle. The different possibilities are described in the tables below.

This 2 bits value selects the first (B1) and second (B2) field components according the table below.

MAPXYZ	B1	B2	Angular
0 – 00b	X	Y	XY mode
1 – 01b	Zx	X	XZx mode
2 – 10b	Y	Zx	YZx mode
3 – 11b	Y	Zy	YZy mode

Note: MAPXYZ = 3 is not recommended.

15.4.2. SMISM, k and SEL_k Parameters

(i) SMISM

When the mapping (B1=X, B2=Y) is selected, SMSIM defines the sensitivity mismatch factor that is applied on B1, B2; When another B1, B2 mapping is selected, this parameter is “don’t care”. This parameter is trimmed at factory; Melexis strongly recommends TO NOT overwrite it for optimal performances.

(ii) k

When the mapping (B1=X, B2=Y) is **NOT** selected, k defines the sensitivity mismatch factor that is applied on B1 or B2 (according to parameter SEL_k – see below). When the mapping (B1=X, B2=Y) is selected, this parameter is “don’t care”. This parameter is trimmed at factory for mapping (B1=Z, B2=X). Melexis recommends to fine trim it when a smaller linearity error (Le) is required and a different mapping than (B1=X, B2=Y) is selected.

(iii) SEL_k

When the mapping (B1=X, B2=Y) is **NOT** selected, SEL_k defines the component on which the sensitivity mismatch factor k (see above): SEL_k = 0 means $B1 \rightarrow k \cdot B1$ and SEL_k = 1 means $B2 \rightarrow k \cdot B2$.

15.4.3. GAINMIN and GAINMAX Parameters

GAINMIN and GAINMAX define the thresholds on the gain code outside which the fault “GAIN out of Spec.” is set; If GAINSATURATION is set, then the virtual gain code is saturated at GAINMIN and GAINMAX, and no Diagnostic fault is set since the saturations applies before the Diag. check.

15.4.4. GAINMIN and GAINMAX Parameters

GAINMIN and GAINMAX define the boundaries within the virtual gain setting is allowed to vary. Outside this range, the output is set in diagnostic mode.

15.5. Filter

Parameter	Value
FILTER	0 ... 2
FHYST	0 ... 255

The MLX90364 includes 2 types of filters:

- Hysteresis Filter: programmable by the FHYST parameter
- Low Pass FIR Filters controlled with the FILTER parameter

15.5.1. Hysteresis Filter

The FHYST parameter is a hysteresis filter. The output value of the IC is not updated when the digital step is smaller than the programmed FHYST parameter value. The output value is modified when the increment is bigger than the hysteresis. The hysteresis filter reduces therefore the resolution to a level compatible with the internal noise of the IC. The hysteresis must be programmed to a value close to the noise level. (1 lsb = +/- 0.012%)

15.5.2. FIR Filters

The MLX90364 features 2 FIR filter modes controlled with Filter = 1...2. Filter = 0 corresponds to no filtering. The transfer function is described below:

$$y_n = \frac{1}{\sum_{i=0}^j a_i} \sum_{i=0}^j a_i x_{n-i}$$

The filters characteristics is given in the following table:

Filter No (j)	0	1	2
Type	Disable	Finite Impulse Response	
Coefficients a _i	1	11	1111
Title	No filter	ExtraLight	Light
99% Response Time	1	2	4
Efficiency RMS (dB)	0	3.0	6.0

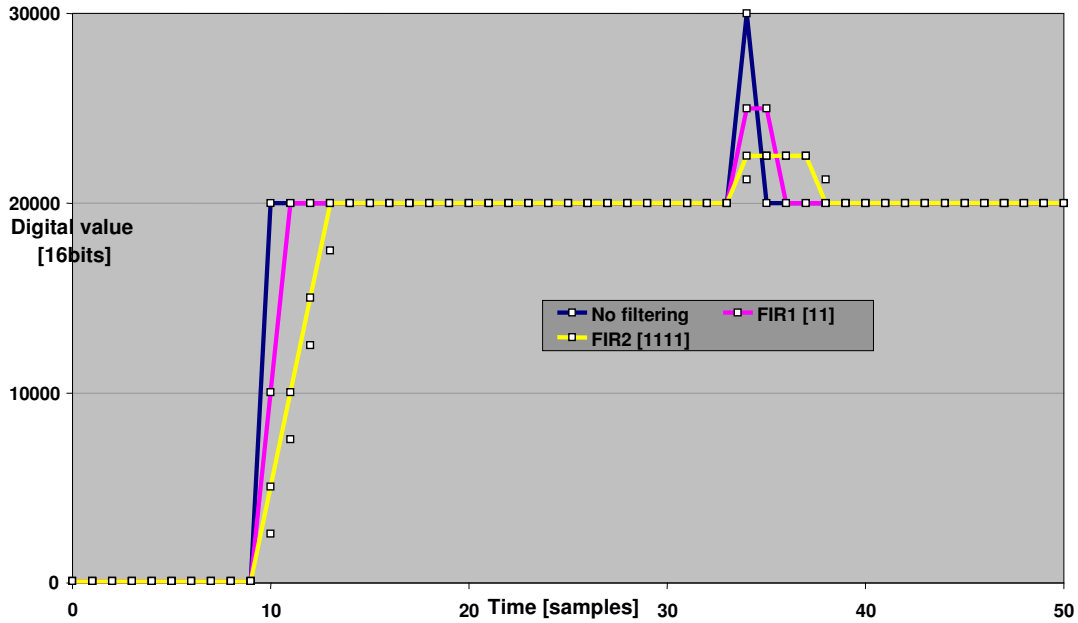

Figure 8 - Step and impulse response of the different filters

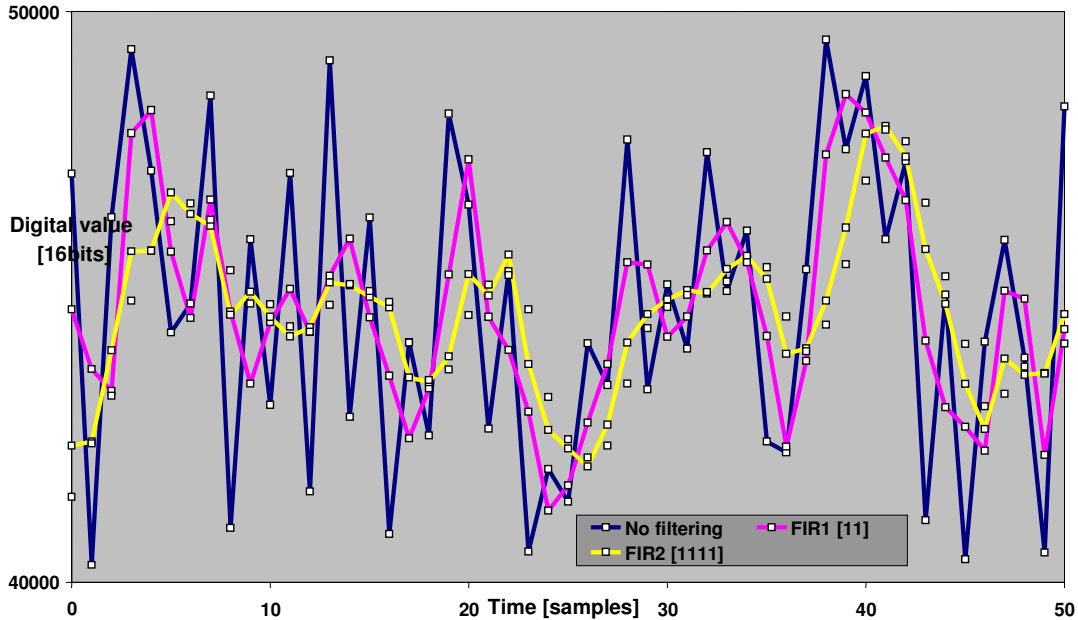

Figure 9 - Noise response of the different filter

15.6. Programmable Diagnostic Settings

15.6.1. DIAG mode

Defines the Output Stage mode in case of Diag.

DIAG mode [2:0]	Type	Descriptions	Comments
0	Disable	Output HiZ	Not recommended
5	Digital	open drain NMOS	
6	Digital	open drain PMOS	
7	Digital	Push-Pull	

15.6.2. DIAG Level

Determines the reporting level (diagnostic low, diagnostic high) during start-up (both analog and PWM mode), or during a fault reporting (Only in Analog mode).

In PWM mode, the fault reporting level shall in principle be 0 when the leading edge is a rising edge, (resp. 1 for a falling edge) in order to detect the first cycle after start-up. MLX recommends then DIAG Level = PWMPOL.

15.6.3. Field Strength Diagnostic (Feature under development)

(i) FIELDTHRESHLOW

Defines the field strength limit under which a fault is reported.
The run-time field strength estimation (FieldStrength) is compared to $256 * \text{FIELDTHRESHLOW}$. The sensitivity of FieldStrength is expected to be: 15.6uV/LSB

The sensitivity of FIELDTHRESHLOW is to be defined

(ii) FIELDTHRESHHIGH

Defines the field strength limit under which a fault is reported. See above for more details.

15.6.4. PWM Diagnostic

(i) DC_FAULT

Defines the duty-cycle that is outputted in case of diagnostic reporting.

(ii) WEAKMAGTHRESH

Defines the threshold on the field strength which determines the weak magnet condition; when WEAKMAGTHRESH = 0, there is no reporting of weak magnet condition.

(iii) DC_FTL

Defines the duty-cycle that is outputted in case of Field Too Low; the Field Too Low Diagnostic is stronger than the Weak Magnet Diagnostic, from 0% till 255% by steps of (100/256)%

(iv) DC_WEAK

Defines the duty-cycle that is outputted in case of Weak Magnet, from 0% till 255% by steps of (100/256)%

15.6.5. Diagnostic Features

Refer to Application_note_Diagnostic_Behavior_90365 for EE_CRC_Enable function description and for Diagnostic features which can be enabled at user.

15.7. EEPROM endurance

Although the EEPROM is used for Calibration Data Storage (similarly to an OTPROM), the MLX90364 embedded EEPROM is qualified to guarantee an endurance of minimum 1000 write cycles at 125°C for (engineering/calibration purpose).

16. MLX90364 Self Diagnostic

The MLX90364 provides numerous self-diagnostic features. Those features increase the robustness of the IC functionality as it will prevent the IC to provide erroneous output signal in case of internal or external failure modes (“fail-safe”).

Diagnostic Item	Action	Effect on Outputs	Type	Monitoring Rate	Reporting Rate
ST-up phase Diagnostics					
RAM March C- 10N Test	Fail-safe mode ** ** CPU reset after 120ms	Diagnostic low/ high Reporting (optional)	Digi HW	n/applicable (start-up only)	n/applicable (start-up only)
Watchdog BIST	Fail-safe mode ** ** CPU reset after 120ms	Diagnostic low/ high Reporting (optional)	Digi HW	n/applicable (start-up only)	n/applicable (start-up only)
FieldTooLow, W/ Programmable Threshold	Diag. (No Debouncing)	Diagnostic low/high Reporting (optional)	Environ &Analog	n/applicable (start-up only)	n/applicable (start-up only)
FieldTooHigh w/ Programmable Threshold	Diag. (No Debouncing)	Diagnostic low/high Reporting (optional)	Environ &Analog	n/applicable (start-up only)	n/applicable (start-up only)
WeakMagnet Diagnostic	Diag. (No Debouncing)	Diagnostic low/high Reporting (optional)	Environ	n/applicable (start-up only)	n/applicable (start-up only)
Under Voltage Monitoring SUPPLYMONI = (MT3VB) OR (MT4VB)	St-up on Hold	Diagnostic low/high	Environ &Analog	n/applicable (start-up only)	n/applicable (start-up only)
Over Voltage Monitoring MT7V	PTC entry	OUT in HiZ	Environ	n/applicable (start-up only)	n/applicable (start-up only)
BG Loop Diag.					
ROM 16bit checksum (continuous)	Fail-safe mode ** ** CPU reset after 120ms	Diagnostic low/high Reporting (optional)	Digi HW	800ms	800ms
RAM Test (continuous)	Fail-safe mode ** ** CPU reset after 120ms	Diagnostic low/high Reporting (optional)	Digi HW	160ms	160ms
EEPROM 8 bit CRC Check (continuous)	Fail-safe mode ** ** CPU reset after 120ms	Diagnostic low/high Reporting (optional)	Digi HW	10ms	10ms
Watchdog (continuous)	CPU reset	--	Digi HW	120ms	n/a
DSP Loop Diag.					
ADC Clipping ADCCCLIP	Debouncing (prog.)	Diagnostic low/high Reporting (optional)	Environ &Analog	5/DSP	6ms x INT (THRES/STEP_UP)
FieldTooLow, W/ Programmable Threshold	Debouncing (prog.)	Diagnostic low/high Reporting (optional)	Environ &Analog	1/DSP	6ms x INT (THRES/STEP_UP)
FieldTooHigh w/ Programmable Threshold	Debouncing (prog.)	Diagnostic low/high Reporting (optional)	Environ &Analog	1/DSP	6ms x INT (THRES/STEP_UP)
WeakMagnet Diagnostic	Debouncing (prog.)	Diagnostic low/high Reporting (optional)	Environ	1/DSP	6ms x INT (THRES/STEP_UP)
Virtual Gain Code Out-of-spec GAINOOS	Debouncing (prog.)	Diagnostic low/high Reporting (optional)	Environ &Analog	1/DSP	6ms x INT (THRES/STEP_UP)

Virtual Gain Code Saturation [GAINMIN..GAINMAX]	Saturation (optional)	Gain Saturated @ GAINMIN-GAINMAX	Environ &Analog	n/applicable Not a diagnostic	n/applicable Not a diagnostic
ADC Monitor (Analog to Digital Converter) <i>ADCMONI</i>	Debouncing (prog.)	Diagnostic low/high Reporting (optional)	Analog HW	1/DSP	6ms x INT (THRES/STEP_UP)
Under Voltage Monitoring <i>SUPPLYMONI = (MT3VB) OR (MT4VB)</i>	Supply Debouncing (prog.)	Diagnostic low/high Reporting (optional)	Environ &Analog	1/DSP	6ms x INT (THRES/STEP_UP)
Over Voltage Monitoring <i>MT7V</i>	PTC entry after PTC Debouncing	OUT in HiZ	Environ	2ms	2ms
Temperature Sensor Monitor <i>TEMPMONI</i>	Debouncing (prog.)	Diagnostic low/high Reporting (optional)	Analog	1/DSP	6ms x INT (THRES/STEP_UP)
Temperature > 170degC (± 20) Temperature < -60degC (± 20)	Saturate value used for the compensations to -40degC and +150degC resp.	No effect	Environ &Analog		n/applicable Not a diagnostic
Hardware Diag. (continuously checked by dedicated Logic)					
Read/Write Access out of physical memory	Fail-safe mode ** ** CPU reset after 120ms	Diagnostic Low/High	Digi HW	n/a immediate Diag	n/a immediate Diag
Write Access to protected area (IO and RAM Words)	Fail-safe mode ** ** CPU reset after 120ms	Diagnostic low/high	Digi HW	n/a immediate Diag.	n/a immediate Diag.
Unauthorized Mode Entry	Fail-safe mode ** ** CPU reset after 120ms	Diagnostic low/high	Digi HW	n/a immediate Diag	n/a immediate Diag
EEPROM Error Correcting Code (Hamming correction)	(Transparent) Error Correction	no effect	Digi HW	n/a.	n/a
Hardware Diag. (continuously checked by dedicated Analog circuits)					
Broken VSS	CPU Reset on recovery	Pull down load => Diag. Low Pull up load => Diag. High	Environ	n/a immediate Diag.	n/a immediate Diag.
Broken VDD	CPU Reset on recovery	Pull down load => Diag. Low Pull up load => Diag. High	Environ	n/a immediate Diag	n/a immediate Diag
Resistive Cable Test	St-up on Hold	Diagnostic low/high	Environ	n/a immediate Diag.	n/a immediate Diag.

17. Built-in Capacitors and recommended Application Diagrams

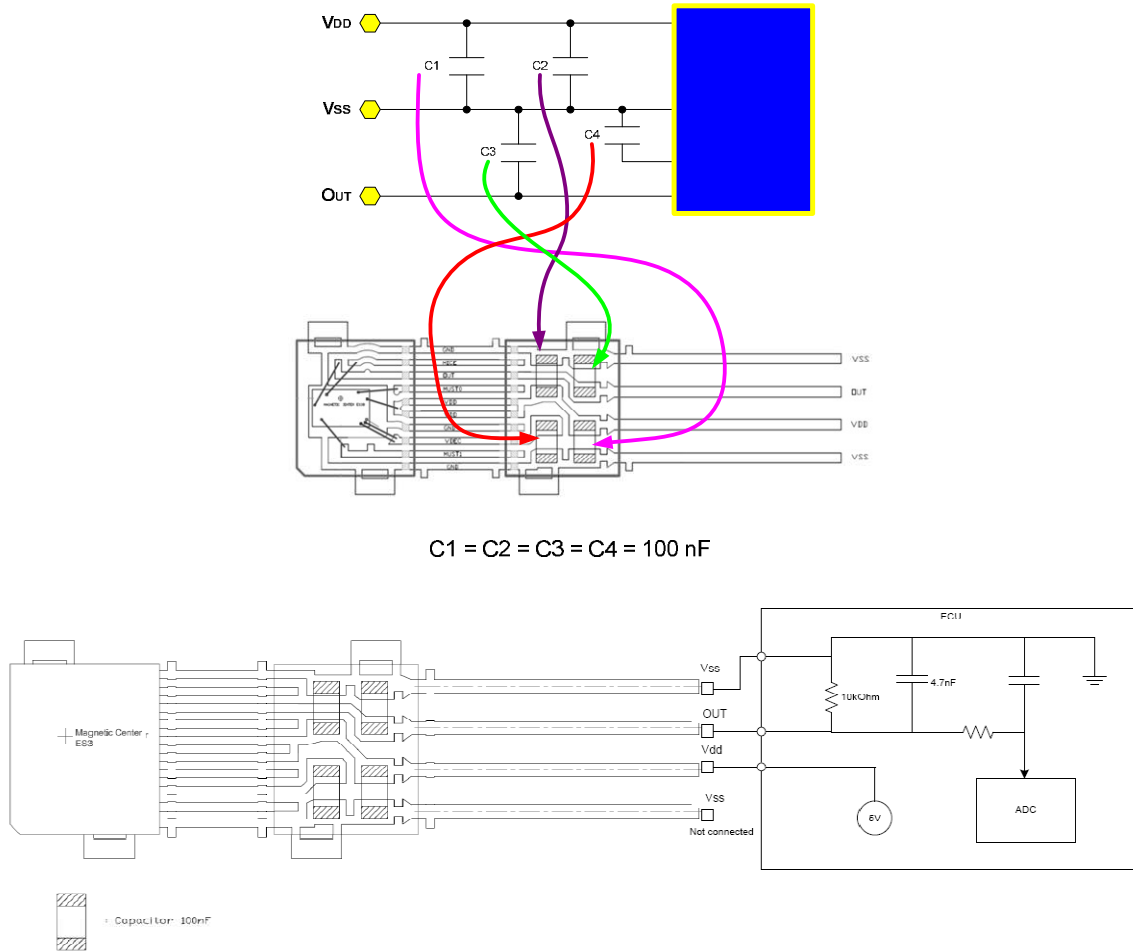

Figure 12 – Recommended wiring for the MLX90364 in DMP-4

Either Vss pin can be used for grounding, but always leave 1 floating.
 Built-in capacitors are ceramic multilayer type X8R with value of 100nF each.
 The capacitors are specifically suited for high temperature applications with stable capacitance value (+/- 15%) up to 150 DegC.
 The capacitors are assembled using a gluing method instead of soldering to be more reliable towards thermal/mechanical stress.
 The maximum rated voltage is 25V.

18. Standard information regarding manufacturability of Melexis products with different lead pre-forming and soldering/welding processes

For Dual Mold Package, please refer to the following document (available upon request):
[Application Note Hall Sensors in Dual Mold Packages – \(Doc#: 390110000001\)](#)

For more information on the lead free topic please see quality page at our website:
<http://www.melexis.com/quality.aspx>

19. ESD Precautions

Electronic semiconductor products are sensitive to Electro Static Discharge (ESD). Always observe Electro Static Discharge control procedures whenever handling semiconductor products.

20. Package Information

20.1. DMP-4 – Package Outline Dimensions (POD) – Straight Leads

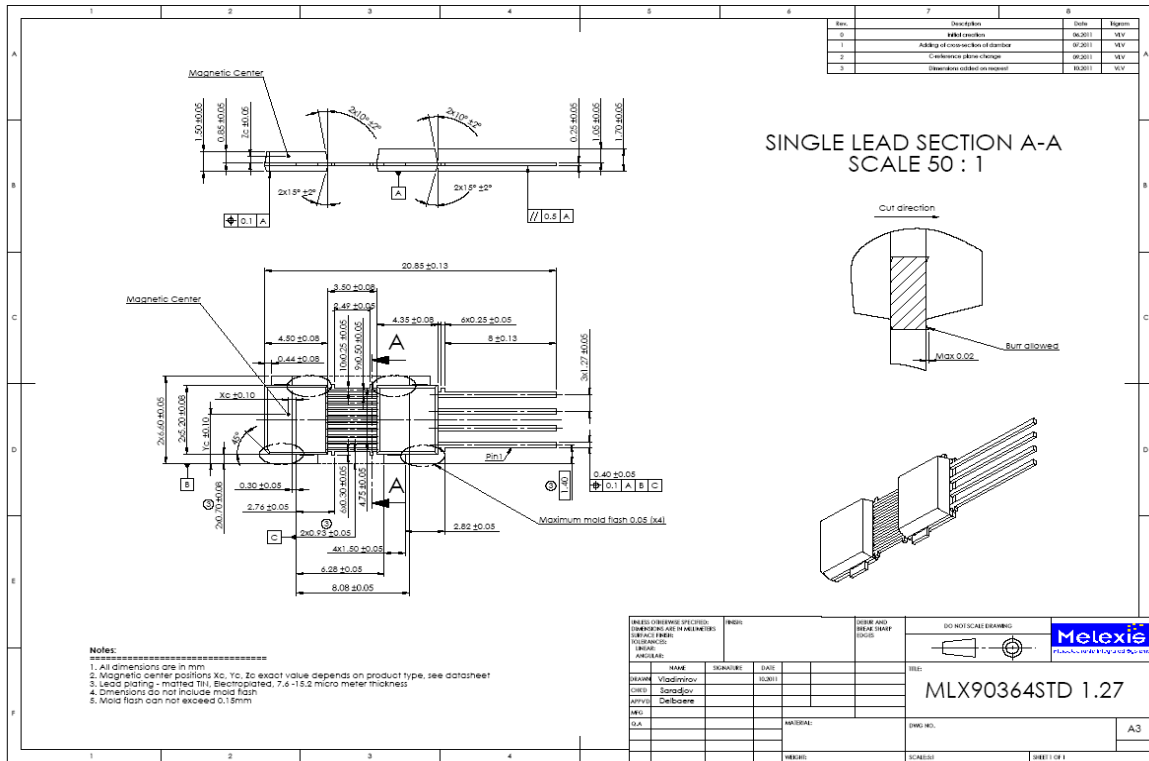

20.2. DMP-4 – Package Outline Dimensions (POD) – Trimmed & Formed Leads [1]

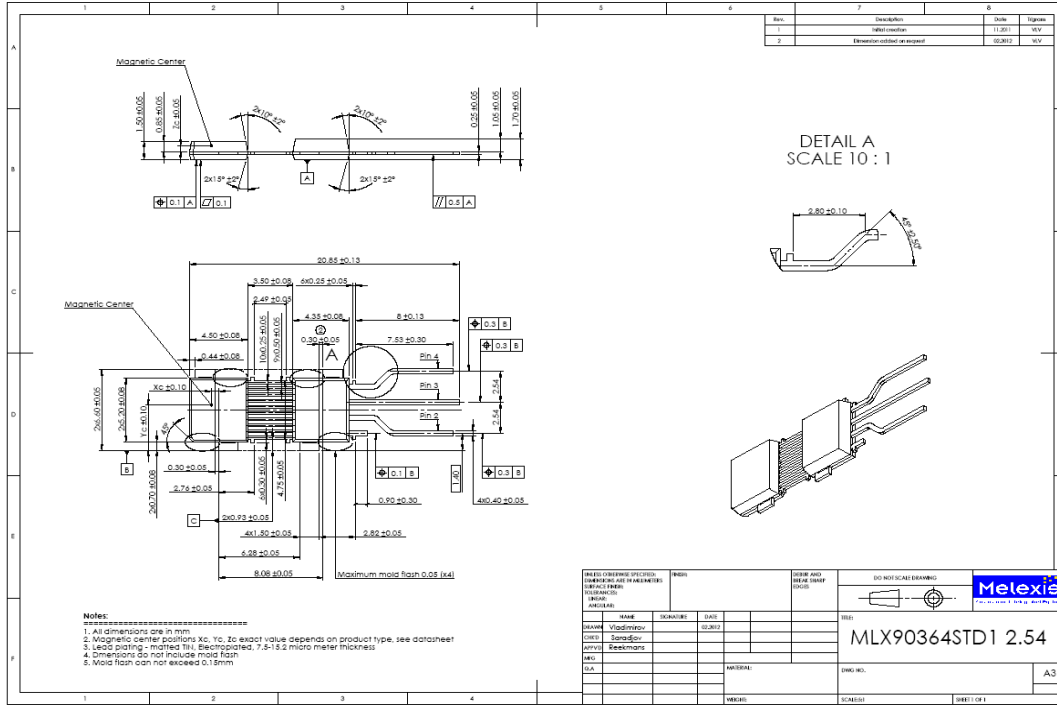

MLX90364LVS-xxx-201

20.3. DMP-4 – Package Outline Dimensions (POD) – Trimmed & Formed Leads [2]

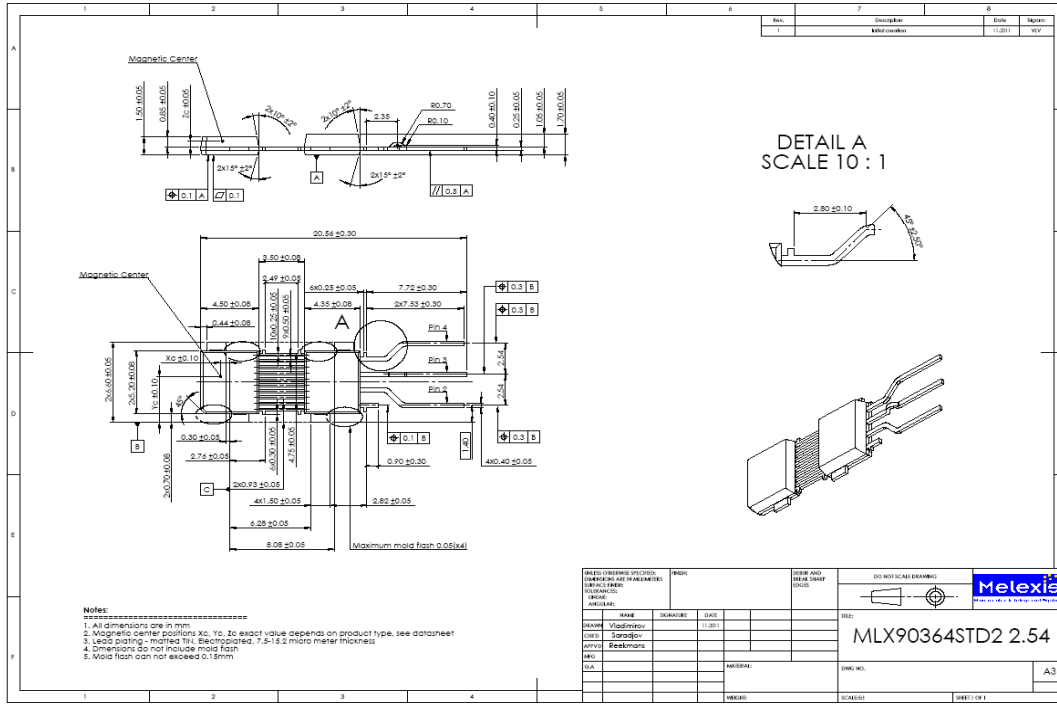

20.4. DMP-4 - Pinout and Marking

Pin #	
1	VSS (Ground)
2	VDD
3	OUT
4	VSS (Ground)

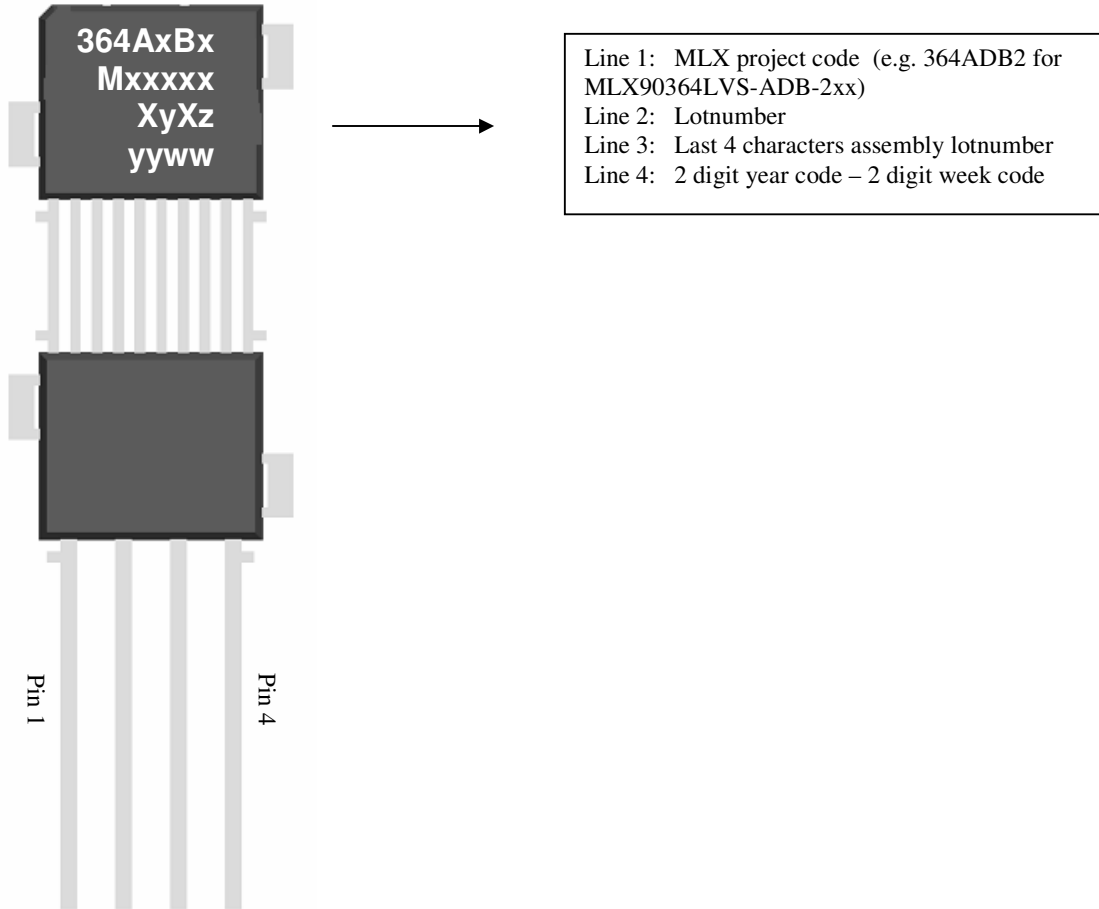

20.5. DMP-4 - Sensitive Spot Positioning & Sense direction

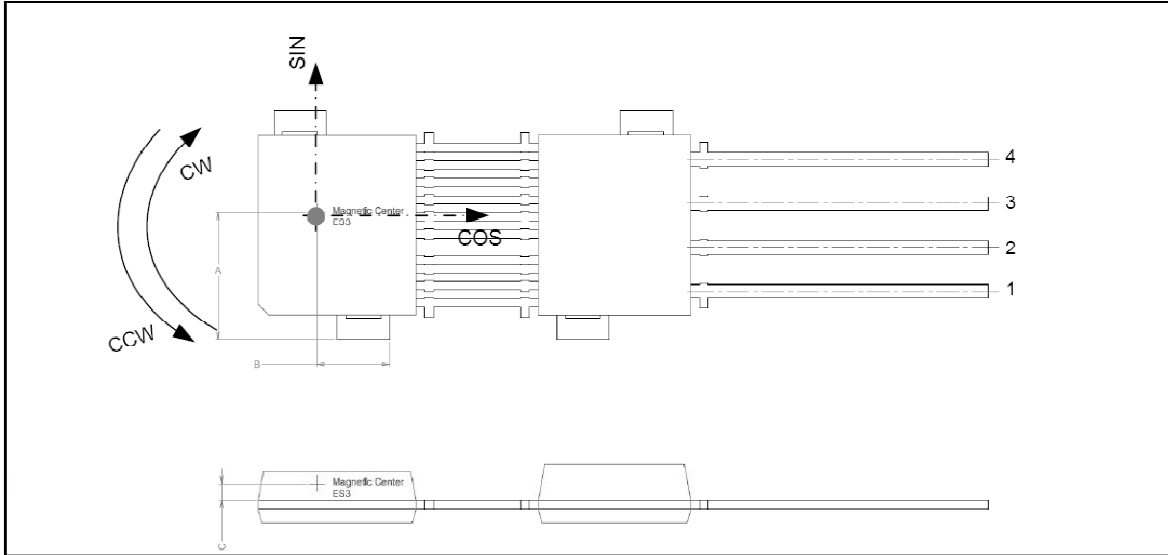

Magnetic center position	MLX90364LVS-AxB-1xx	MLX90364LVS-AxB-2xx
Xc	0.57	0.23
Yc	3.69	3.67
Zc	0.495	0.495

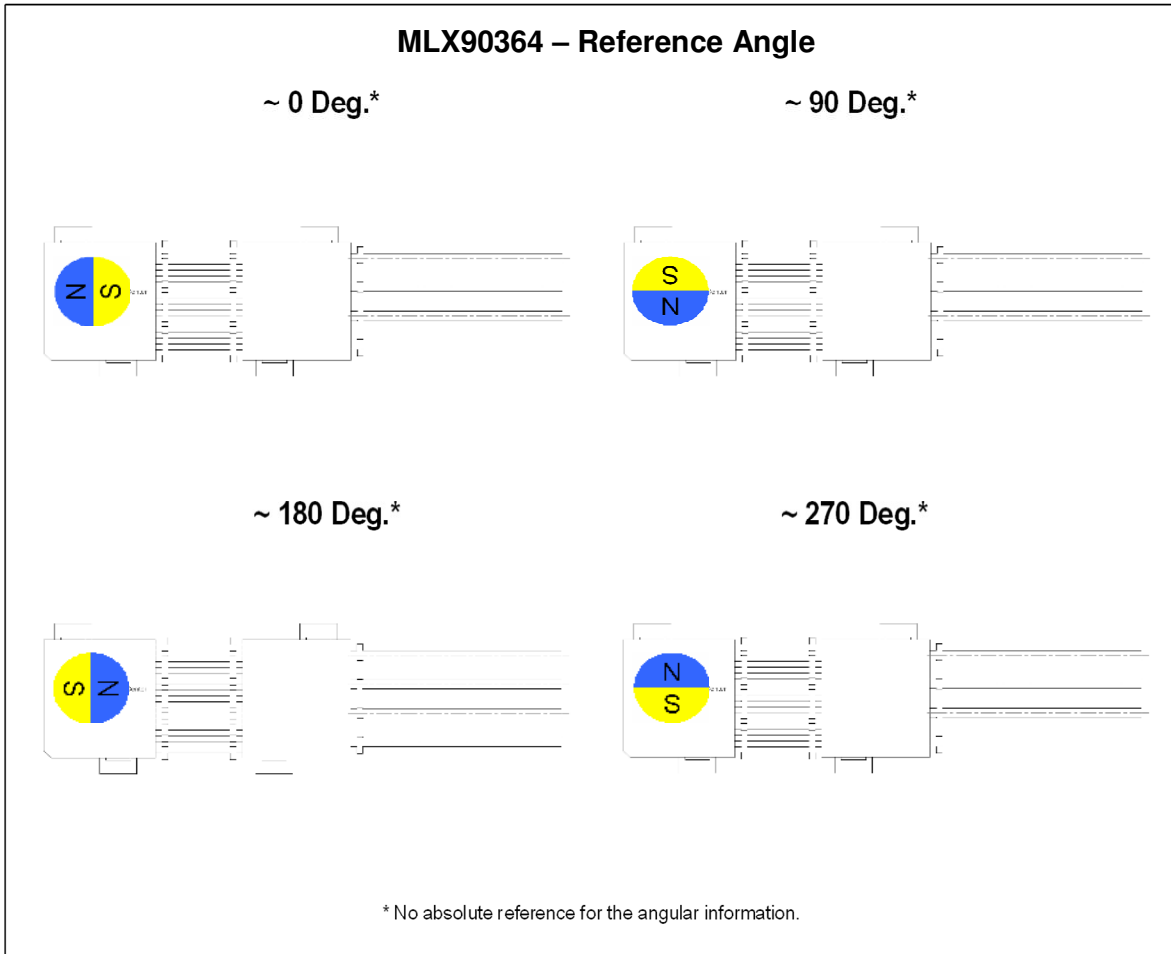

The MLX90364 is an absolute angular position sensor but the linearity error (See section 0) does not include the error linked to the absolute reference 0 Deg (which can be fixed in the application through the discontinuity point).

21. Disclaimer

Devices sold by Melexis are covered by the warranty and patent indemnification provisions appearing in its Term of Sale. Melexis makes no warranty, express, statutory, implied, or by description regarding the information set forth herein or regarding the freedom of the described devices from patent infringement. Melexis reserves the right to change specifications and prices at any time and without notice. Therefore, prior to designing this product into a system, it is necessary to check with Melexis for current information. This product is intended for use in normal commercial applications. Applications requiring extended temperature range, unusual environmental requirements, or high reliability applications, such as military, medical life-support or life-sustaining equipment are specifically not recommended without additional processing by Melexis for each application.

The information furnished by Melexis is believed to be correct and accurate. However, Melexis shall not be liable to recipient or any third party for any damages, including but not limited to personal injury, property damage, loss of profits, loss of use, interrupt of business or indirect, special incidental or consequential damages, of any kind, in connection with or arising out of the furnishing, performance or use of the technical data herein. No obligation or liability to recipient or any third party shall arise or flow out of Melexis' rendering of technical or other services.

© 2012 Melexis N.V. All rights reserved.

For the latest version of this document, go to our website at www.melexis.com

Or for additional information contact Melexis Direct:

Europe, Africa:	Americas:	Asia:
Phone: +32 1367 0495	Phone: +1 248-306-5400	Phone: +32 1367 0495
E-mail: sales_europe@melexis.com	E-mail: sales_usa@melexis.com	E-mail: sales_asia@melexis.com

ISO/TS 16949 and ISO14001 Certified