

DESCRIPTION

The LX1744 is a compact high efficiency step-up boost regulator for driving white or color LEDs in LCD lighting applications while supplying the necessary LCD bias voltage with an additional integrated boost converter.

Designed for maximum efficiency and featuring a pseudo-hysteretic PFM topology (that decreases output voltage ripple), the LX1744 minimizes system cost and condenses layout area making it ideal for PDA, smart-phone, and digital camera applications.

While the LCD Bias generation is implemented using an internal N-Channel MOSFET, the LED driver utilizes an external N-Channel MOSFET in order to maintain maximum efficiency along with flexible power requirements.

The LX1744's control circuitry is optimized for portable systems with a shutdown current of less than 1µA. The input voltage range of 1.6V to 6.0V allows for a wide selection of system battery voltages and start-up is guaranteed at a V_{IN}

equal to 1.6V with sustained operation as low as 1.1V.

The maximum LED drive current is easily programmed using one external current sense resistor in series with the LEDs. In this configuration, LED current provides a feedback signal to the FB pin, maintaining constant current regardless of varying LED forward voltage (V_F). Depending on the MOSFET selected, the LX1744 is capable of achieving an LED drive in excess of 1.0W.

The LX1744 provides simple dynamic adjustment of the LED drive current (0% to 100% full range dimming) and the LCD Bias output voltage (up to $\pm 15\%$ typ) through separate IC interfaces. Each interface has an internal RC filter allowing designers to make these adjustments via a direct PWM input signal or an analog reference signal. Further, any PWM amplitude is easily accommodated using a single external resistor.

The LX1744 is available in the 14-Pin TSSOP, and the miniature 16-Pin MLP requiring minimal PCB area.

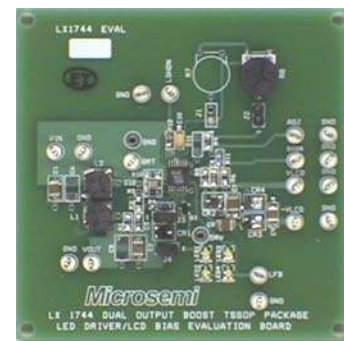
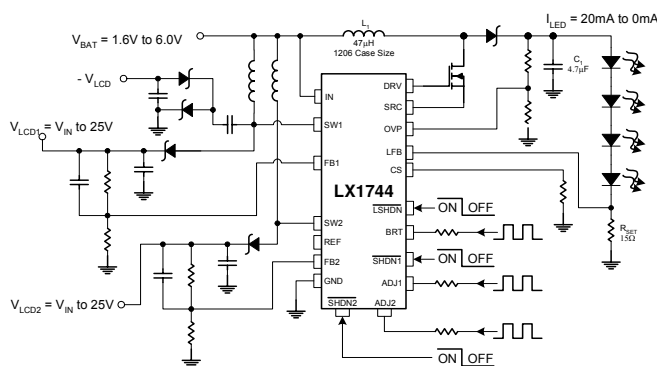
KEY FEATURES

- > 90% Maximum Efficiency
- Low Quiescent Supply Current
- Externally Programmable Peak Inductor Current Limit for Maximum Efficiency
- Logic Controlled Shutdown
- < 1µA Shutdown Current
- Dynamic Output LED Current and LCD Bias Voltage Adjustment via Analog Reference or Direct PWM Input
- 14-Pin TSSOP or 16-Pin MLPQ Package

APPLICATIONS

- Pagers
- Smart Phones
- PDAs
- Handheld Computers
- General LCD Bias Applications
- LED Driver

IMPORTANT: For the most current data, consult MICROSEMI's website: <http://www.microsemi.com>

PRODUCT HIGHLIGHT


LX1744 Evaluation Board

PACKAGE ORDER INFO

T_A (°C)	PW Plastic TSSOP 14-Pin	LQ Plastic MLP-Q 16-Pin
	-40 to 85	RoHS Compliant / Pb-free Transition DC: 0442 LX1744CPW

Note: Available in Tape & Reel.
Append the letters "TR" to the part number. (i.e. LX1744CLQ-TR)

ABSOLUTE MAXIMUM RATINGS

Supply Input Voltage.....	-0.3V to 7V
Feedback Input Voltage (V_{FB} , V_{LFB}).....	-0.3V to $V_{IN} + 0.3V$
Shutdown Input Voltage (V_{SHDN} , V_{LSHDN}).....	-0.3V to $V_{IN} + 0.3V$
PWM Input Amplitude (ADJ, BRT).....	-0.3V to $V_{IN} + 0.3V$
Analog Adjust Input Voltage (V_{ADJ} , V_{BRT}).....	-0.3V to $V_{IN} + 0.3V$
SRC Input Current.....	800mA _{RMS}
Operating Temperature Range.....	-40°C to 85°C
Maximum Operating Junction Temperature.....	150°C
Storage Temperature Range.....	-65°C to 150°C
RoHS Peak Package Solder Reflow Temperature (40 second maximum exposure).....	260°C (+0, -5)

Note: Exceeding these ratings could cause damage to the device. All voltages are with respect to Ground. Currents are positive into, negative out of specified terminal.

THERMAL DATA
LQ Plastic MLPQ 16-Pin

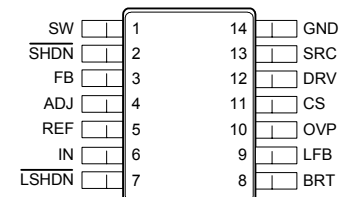
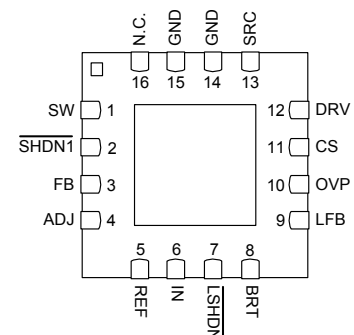
THERMAL RESISTANCE-JUNCTION TO AMBIENT, θ_{JA}	31°C/W
---	--------

PW Plastic TSSOP 14-Pin

THERMAL RESISTANCE-JUNCTION TO AMBIENT, θ_{JA}	90°C/W
---	--------

Junction Temperature Calculation: $T_J = T_A + (P_D \times \theta_{JA})$.

The θ_{JA} numbers are guidelines for the thermal performance of the device/pc-board system. All of the above assume no ambient airflow.

PACKAGE PIN OUT

PW PACKAGE
(Top View)

LQ PACKAGE
(Bottom View)

("N.C." = No Internal Connection)

RoHS / Pb-free 100% Matte Tin Lead Finish

FUNCTIONAL PIN DESCRIPTION

Name	Description
IN	Unregulated IC Supply Voltage Input – Input range from +1.6V to 6.0V. Bypass with a 1 μ F or greater capacitor for operation below 2.0V.
DRV	LED MOSFET Gate Driver – Connects to an external N-Channel MOSFET.
SRC	LED MOSFET Current Sense Input - Connects to the External N-Channel MOSFET Source.
OVP	Over Voltage Programming Pin – Connects to a resistor divider between the output load and GND to set the maximum output voltage. OVP has a voltage threshold of 1.2V
LFB	LED Current Feedback Input – Connects to a current sense resistor between the LED output load and GND to set the LED drive current.
GND	Common terminal for ground reference.
BRT	LED Dimming Signal Input – Provides the internal reference, via an internal filter and gain resistor, allowing for a dynamic output LED current adjustment that corresponds to the PWM input signal duty cycle. Either a PWM signal or analog voltage can be used. The actual BRT pin voltage range is from V_{IN} to GND. Minimize the current sense resistor power dissipation by selecting a range for $V_{BRT} = 0.0V$ to 0.5V.
REF	Buffered Reference Output – Connected to the internal bandgap reference voltage of 1.2V.
SW	LCD Bias Inductor Switch Connection – Internally connected to the drain of a 28V N-channel MOSFET. SW is high impedance in shutdown.
FB	Feedback Input – Connect to a resistive divider network between the output and GND to set the output voltage between V_{CC} (IN) and 25V. The feedback threshold is 1.29V.
ADJ	LCD Bias Adjustment PWM Signal Input – Connect to an RC filter allowing for dynamic output voltage adjustment $>\pm 15\%$, corresponding to a varying duty cycle. Either a PWM signal or analog voltage can be used. The ADJ input voltage range is from 0.9V to V_{IN} DC. The ADJx pin should be connected to ground when the internal reference is used.
$\overline{\text{LSHDN}}$	LED Driver Active-Low Shutdown Input – A logic low shuts down the LED driver circuitry and reduces the supply current by 60 μ A (Typ). Pull $\overline{\text{LSHDN}}$ high for normal operation.
$\overline{\text{SHDNx}}$	LCD Bias Active-Low Shutdown Input – A logic low shuts down the LCD Bias circuitry and reduces the supply current by 60 μ A (Typ). Pull $\overline{\text{SHDNx}}$ high for normal operation.
CS	Current-Sense Amplifier Input – Connecting a resistor between CS and GND sets the peak inductor current limit.

ELECTRICAL CHARACTERISTICS

Unless otherwise specified, the following specifications apply over the operating ambient temperature $0^{\circ}\text{C} \leq T_A \leq 70^{\circ}\text{C}$ except where otherwise noted and the following test conditions: $V_{\text{IN}} = 3\text{V}$, $I_{\text{LED}} = 20\text{mA}$, $\overline{\text{SHDN1}} = V_{\text{IN}}$, $\overline{\text{SHDN2}} = V_{\text{IN}}$

Parameter	Symbol	Test Conditions	LX1744			Units
			Min	Typ	Max	
LED DRIVER						
LFB Threshold Voltage	V_{LFB}	$V_{\text{BRT}} = 100\text{mV}$	95	100	115	mV
		$V_{\text{BRT}} = 20\text{mV}$	5	20	35	
LFB Input Bias Current		$V_{\text{LFB}} = 100\text{mV}$	-100		100	nA
BRT Input Voltage Range	V_{BRT}		0.0		V_{IN}	V
BRT Input Bias Current		$\text{BRT} = V_{\text{REF}}$	0		60	nA
LED Driver Shutdown Input Bias Current	$I_{\overline{\text{SHDN1}}}$	$0.0\text{V} \leq \overline{\text{LSHDN}} \leq V_{\text{IN}}$	-100		100	nA
LED Driver Shutdown High Input Voltage	$V_{\overline{\text{SHDN1}}}$	$V_{\text{IN}} = 2\text{V}$	1.6			V
LED Driver Shutdown Low Input Voltage	$V_{\overline{\text{SHDN1}}}$	$V_{\text{IN}} = 2\text{V}$			0.4	V
Current Sense Bias Current	I_{CS}			4		μA
Efficiency	η	$I_{\text{LOAD}} = 2\text{mA}$		90		%
DRV Sink/Source Current		$V_{\text{IN}} = 5\text{V}$, $\text{DRV} = 3\text{V}$	85	100		mA
DRV On-Resistance		$V_{\text{CC}} = 5\text{V}$		12	15	Ω
Maximum Switch On-Time	t_{ON}	$V_{\text{FB}} = 1\text{V}$			∞	μs
Minimum Switch Off-Time	t_{OFF}	$V_{\text{FB}} = 1\text{V}$	200	300	410	nS
Switch Peak Current	I_{PK}	$R_{\text{CS}} = 0\Omega$ $R_{\text{CS}} = 2\text{k}\Omega$		170 210		mA
OVP Threshold Voltage	V_{OVP}		1.15	1.21V	1.26	V
LCD BIAS						
Output Voltage Range	V_{OUT}				25	V
FB Threshold Voltage	V_{FB}		1.172	1.196	1.220	V
FB Input Current		$V_{\text{FB}} = 1.4\text{V}$			200	nA
LCD Bias Shutdown Input Bias Current	$I_{\overline{\text{SHDN}}}$	$\overline{\text{SHDN}} = \text{GND}$			100	nA
LCD Bias Shutdown High Input Voltage	$V_{\overline{\text{SHDN}}}$	$V_{\text{IN}} = 2\text{V}$	1.6			V
LCD Bias Shutdown Low Input Voltage	$V_{\overline{\text{SHDN}}}$	$V_{\text{IN}} = 2\text{V}$			0.4	V
Peak Inductor Current Limit	I_{LIM}			195		mA
Internal NFET On-resistance	$R_{\text{DS(ON)}}$	$I_{\text{SW}} = 10\text{mA}$, $T_A = 25^{\circ}\text{C}$, $V_{\text{IN}} = 5\text{V}$		1.1		Ω
Switch Pin Leakage Current	I_{LEAK}	$V_{\text{SW}} = 25\text{V}$			1	μA
Efficiency	η	$I_{\text{LOAD}} = 2\text{mA}$		85		%
Switch On-Time	t_{ON}	$V_{\text{FB}} = 1\text{V}$			∞	μs
Switch Off-Time	t_{OFF}	$V_{\text{FB}} = 1\text{V}$	150		400	Ns
ADJ Input Voltage Range	V_{ADJ}		0.9		1.5	V
ADJ Input Bias Current	I_{ADJ}	$V_{\text{ADJ}} = 1.5\text{V}$		0.3	1	μA
ENTIRE REGULATOR						
Operating Voltage	V_{IN}		1.6		6.0	V
Minimum Start-up Voltage		$T_A = +25^{\circ}\text{C}$			1.6	V
Start-up Voltage Temperature Coefficient				-2		mV/ $^{\circ}\text{C}$
Reference Voltage	V_{REF}		1.187	1.21	1.236	V
Quiescent Current	I_{Q}	$V_{\text{FB}} = 0.3\text{V}$, $V_{\text{LFB}} < V_{\text{BRT}} - 0.1\text{V}$		120	200	μA
		$V_{\text{FB}} = 0.3\text{V}$, $V_{\text{LFB}} < V_{\text{BRT}} - 0.1\text{V}$, $V_{\overline{\text{LSHDN}}} < 0.4\text{V}$		60	135	
		$V_{\text{FB}} = 0.3\text{V}$, $V_{\text{LFB}} < V_{\text{BRT}} - 0.1\text{V}$, $V_{\overline{\text{SHDN}}} < 0.4\text{V}$		60	135	
		$V_{\overline{\text{LSHDN}}} < 0.4\text{V}$, $V_{\overline{\text{SHDN}}} < 0.4\text{V}$		0.35	0.5	

SIMPLIFIED BLOCK DIAGRAM

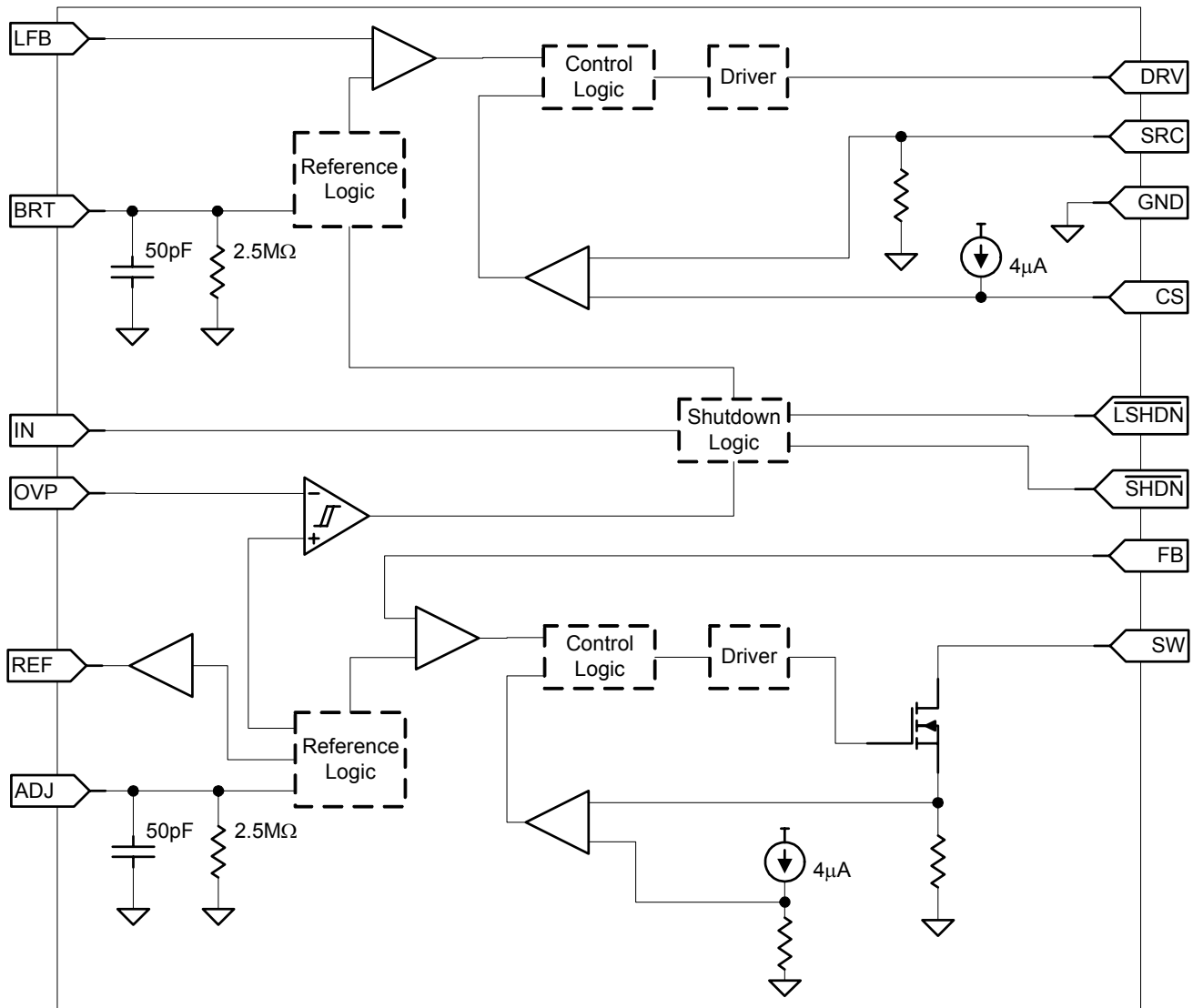


Figure – Simplified Block Diagram

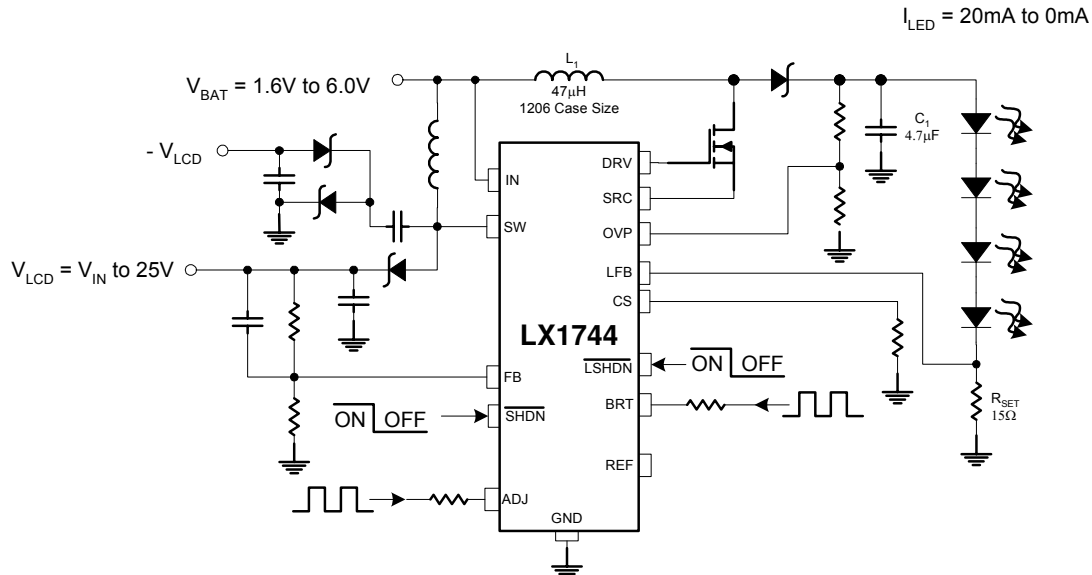
APPLICATION CIRCUITS


Figure 1 – LED Driver with Full-Range Dimming plus LCD Bias With Contrast Adjustment Via PWM Input

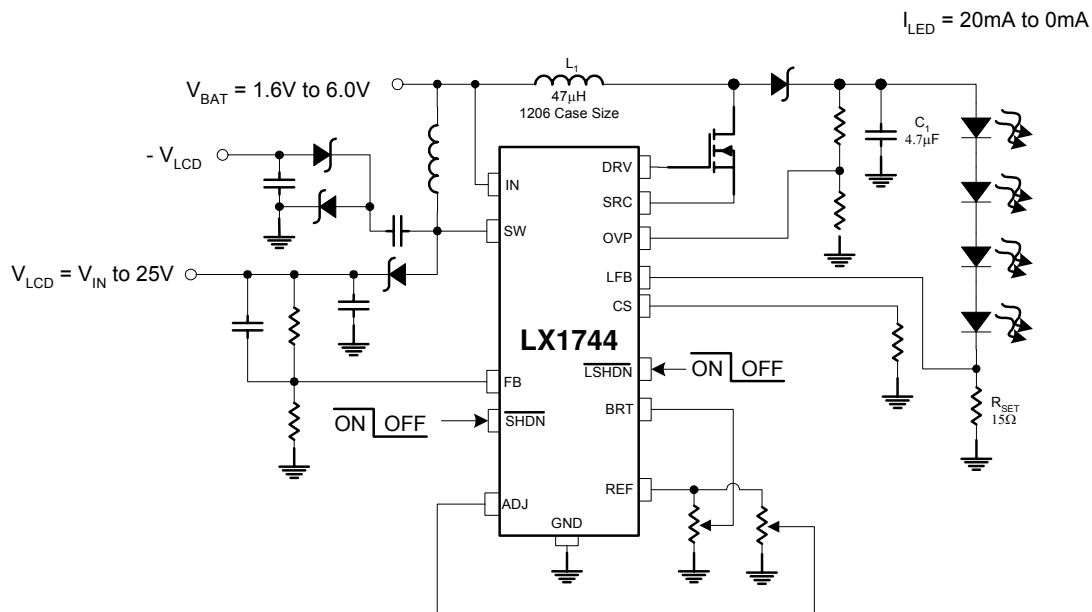


Figure 2 – LED Driver with Full-Range Dimming plus LCD Bias With Contrast Adjustment Via Analog Voltage Input

Note: The component values shown are only examples for a working system. Actual values will vary greatly depending on desired parameters, efficiency, and layout constraints.

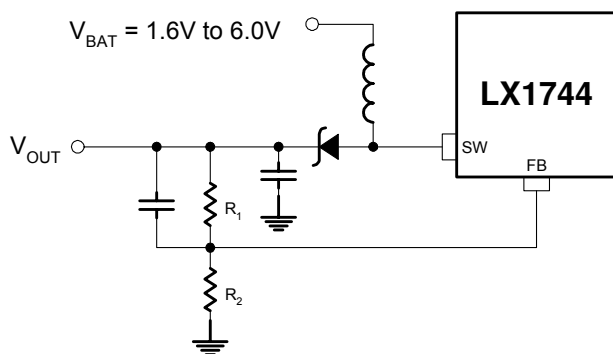
APPLICATION NOTE
FUNCTIONAL DESCRIPTION

The LX1744 is a dual output Pulse Frequency Modulated (PFM) boost converter that is optimized for large step-up voltage applications like LCD biasing and LED drive.

Operating in a pseudo-hysteretic mode with a fixed switch “off time” of 300ns, converter switching is enabled when the feedback voltage (V_{FB}) falls below the bandgap reference voltage or the ADJ pin voltage managed by the reference logic block (see Block Diagram). When this occurs, the feedback comparator activates the switching logic, pulling the gate of the power MOSFET high. This in turn connects the boost inductor to ground causing current to flow building up the energy stored in the inductor. The output remains “on”, until the inductor current ramps up to the peak current level set either by the CS pin programming resistor (R_{CS}) in the case of the LED driver or by an internal reference threshold for the LCD bias output. During this switch cycle, the load is powered from energy stored in the output capacitor. Once the peak inductor current value is achieved, the driver output is turned off, for the fixed off-time period of 300ns, allowing a portion of the energy stored in the inductor to be delivered to the load causing output voltage to rise at the input to the feedback circuit. If the voltage at the feedback pin is less than the internal reference at the end of the off-time period, the output switches the power MOSFET “on” and the inductor charging cycle repeats until the feedback pin voltage is greater than the internal reference. Typical converter switching behavior is shown in Figure 12.

LCD BIAS – OUTPUT VOLTAGE PROGRAMMING

Selecting the appropriate values for LCD Bias output voltage divider (Figure 3), connected to the feedback pin, programs the output voltage.


Figure 3 – LCD Bias Output Voltage

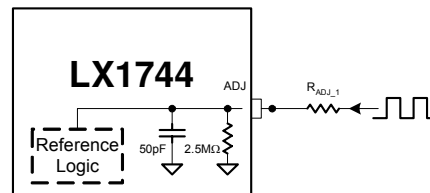
Using a value between 40k Ω and 75k Ω for R_2 works well in most applications. R_1 can be determined by the following equation (where $V_{REF} = 1.19V$ nominal):

$$R_1 = R_2 \frac{V_{OUT} - V_{REF}}{V_{REF}} \quad \text{eq. 1}$$

LCD BIAS – OUTPUT VOLTAGE ADJUSTMENT

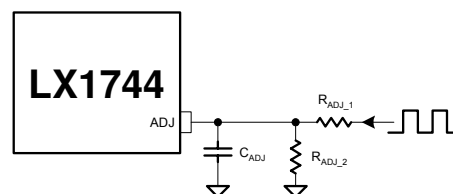
The LX1744 allows for the dynamic adjustment of the of the voltage output via an adjustment pin (ADJ). Any voltage applied to the adjustment pin works in conjunction with the internal reference logic. The LX1744 will automatically utilize the internal reference when no signal is detected or when the adjustment signal voltage is below approximately 0.6V.

This adjustment pin includes an internal 50pF capacitor to ground (Figure 4) that works with an external resistor to create a low-pass filter. This allows a direct PWM ($f_{PWM} \geq 100KHz$) signal input to be used for the voltage adjustment signal. (Consequently a DC bias signal can also be used).


Figure 4 – LCD Bias Adjustment Input

Different PWM signal levels can be accommodated by selecting a value for R_{PWM} such that the filtered V_{ADJ} value is equal to the reference voltage (eq. 2)

$$V_{ADJ} = V_{PWM} \cdot \text{Duty Cycle} \cdot \left(\frac{2.5M\Omega}{2.5M\Omega + R_{PWM_1}} \right) \quad \text{eq. 2}$$


Figure 5 – LCD Bias Adjustment Input Filter

Ideally the resultant ripple on the ADJ pin should be approximately 1% or 40dB down from the nominal reference. When using a PWM with a frequency that is

APPLICATION NOTE

less than 100kHz, an external filter capacitor will be needed (Figure 5). The value of $C_{P_{PWM}}$ is easily calculated based on the PWM frequency and $R_{P_{PWM_1}}$ using the following equation.

$$C_{P_{PWM}} = \frac{50}{\pi \cdot f_{P_{PWM}} \cdot R_{P_{PWM_1}}} \quad \text{eq. 3}$$

where

$$R_{P_{PWM_1}} \ll 2.5M\Omega \quad \text{eq. 4}$$

LED DRIVER – OUTPUT CURRENT PROGRAMMING

Maximum LED current is easily programmed by choosing the appropriate value for R_{LED} (Figure 6). It is recommended that a minimum value of 15Ω be used for this resistor in order to prevent noise coupling issues on the feedback line. Although, alternate values can be calculated using the following equation:

$$R_{LED} = \frac{V_{BRT(MAX)}}{I_{LED(MAX)}} \quad \text{eq. 5}$$

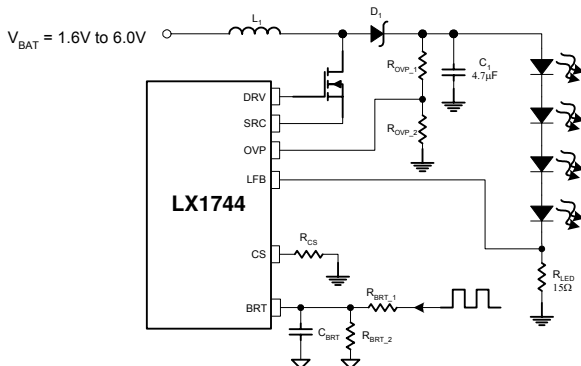


Figure 6 – LED Current Programming

LED DRIVER – LED BRIGHTNESS ADJUSTMENT

The LX1744 features a full range dimming LED driver. LED current regulation is accomplished by using the applied BRT pin voltage as the LED current reference. This reference voltage, in conjunction with the LED current setting resistor (R_{LED}), sets the LED output current.

Dimming can be accomplished in one of two ways: by applying a variable DC voltage, or by varying the duty cycle (DC) of a PWM control signal, directly to the BRT pin.

It is recommended that a maximum signal voltage of

300mV (V_{BRT}) be used in order to minimize dissipative losses in the LED current sense resistor (R_{LED}).

Like the LCD bias adjustment (ADJ) pin, the BRT pin is connected to an internal 50pF capacitor to ground that works with an external resistor to create a low-pass filter, allowing the BRT pin to driven directly by a PWM signal whose frequency is greater than 100kHz. When this pin is driven by a PWM signal whose frequency is less than 100kHz, an external filter capacitor is needed. This capacitor is selected such that the ripple component of the resultant voltage on the BRT pin is less than 10% of the nominal input voltage.

For PWM frequencies greater than 100kHz, the external BRT input resistor is calculated using the following equation.

$$R_{BRT_1} = 2.5M\Omega \cdot \left(\frac{V_{P_{PWM}}(DC_{MAX}) - V_{BRT(MAX)}}{V_{BRT(MAX)}} \right) \quad \text{eq. 6}$$

where V_{BRT} is the selected maximum LED current sense feedback threshold.

For PWM frequencies less than 100kHz, the external BRT input resistors and filter capacitor (Figure 4) are calculated using the following equations.

$$R_{BRT_1} = R_{BRT_2} \cdot \left(\frac{V_{P_{PWM}}(DC_{MAX}) - V_{BRT(MAX)}}{V_{BRT(MAX)}} \right) \quad \text{eq. 7}$$

where R_{BRT_2} is selected and $V_{BRT(MAX)}$ is the selected maximum LED current sense feedback threshold.

$$C_{BRT} = \frac{5}{\pi \cdot f_{P_{PWM}}} \cdot \left(\frac{R_{BRT_1} + R_{BRT_2}}{R_{BRT_1} \cdot R_{BRT_2}} \right) \quad \text{eq. 8}$$

where V_{RIPPLE} is selected to be 10% of V_{BRT} , and $f_{P_{PWM}}$ is the PWM signal frequency.

DIODE SELECTION

A Schottky diode is recommended for most applications (e.g. Microsemi UPS5817). The low forward voltage drop and fast recovery time associated with this device supports the switching demands associated with this circuit topology. The designer is encouraged to consider the diode's average and peak current ratings with respect to the application's output and peak inductor current requirements. Further, the diode's reverse breakdown voltage characteristic must be capable of withstanding a

APPLICATION NOTE

negative voltage transition that is greater than the output voltage.

POWER MOSFET SELECTION

The LX1744 can source up to 100mA of gate current. A logi-level N-channel MOSFET with a low turn on threshold voltage, low gate charge and low $R_{DS(ON)}$ is required to optimize overall circuit performance.

OVER VOLTAGE PROTECTION PROGRAMMING

Since the output of the LED Driver is a current mode configuration, it may be desirable to protect the output from an over-voltage condition in the event the load is removed or not present.

The LX1744 includes an over voltage monitor that is easily programmed with two external resistors (Figure 6). This feature eliminates the need for a Zener Diode clamp on the output.

Programming is accomplished by first selecting R_{OVP_2} and then calculating R_{OVP_1} using the following equation.

$$R_{OVP_1} = R_{OVP_2} \frac{V_{OVP} - V_{REF}}{V_{REF}} \quad \text{eq. 9}$$

where V_{OVP} is the desired maximum voltage on the output. This voltage should be selected to accommodate the maximum forward voltage of all the LEDs, over temperature, plus the maximum feedback voltage. Conversely, it may also be selected according to the maximum V_{DS} voltage of the output MOSFET.

INDUCTOR CURRENT LIMIT PROGRAMMING

Setting of the peak inductor current limit is an important aspect of the PFM constant off-time architecture; it determines the maximum output power capability and has a marked effect on efficiency.

It is recommended that the peak inductor current be set to approximately two times the expected maximum DC input current. This setting will minimize the inductor size, the input ripple current, and the output ripple voltage. Care should be taken to use inductors that will not saturate at the peak inductor current level. The desired peak inductor current can be estimated by the following equation:

$$I_{PK} = 2 \cdot \frac{P_{OUT}}{\eta \cdot V_{IN}} \quad \text{eq. 10}$$

where P_{OUT} is the total output power, η is the expected conversion efficiency, and V_{IN} is the input voltage.

From the calculated desired I_{PK} an R_{CS} resistance value

can be chosen from the following equation:

$$R_{CS} \cong \frac{I_{PK} - 0.185}{30 \cdot 10^{-6}} \quad \text{eq. 11}$$

which is taken from the following graph (Figure 7).

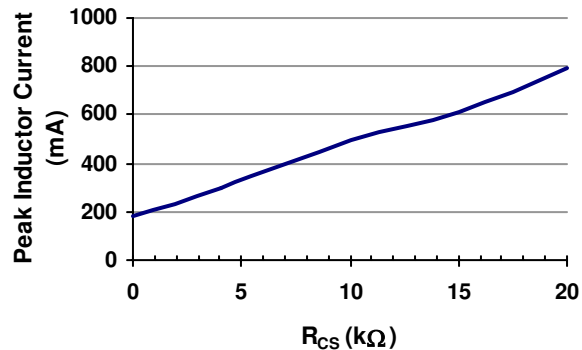


Figure 7 – Peak Current Programming Resistor

This graph characterizes the relationship between peak inductor current, the inductance value, and the R_{CS} programming resistor.

INDUCTOR SELECTION

An inductor value of 47μH has been shown to yield very good results. Choosing a lower value emphasizes peak current overshoot, effectively raises the switching frequency, and increases the dissipative losses due to increased currents.

OUTPUT CAPACITOR SELECTION

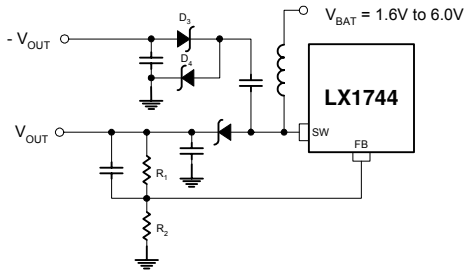
Output voltage ripple is a function of the several parameters: inductor value, output capacitance value, peak switch current, load current, input voltage, and the output voltage. All of these factors can be summarized by the following equation:

$$V_{RIPPLE} \cong \left(\frac{L \cdot I_{PK} \cdot I_{OUT}}{C_{OUT}} \right) \left(\frac{1}{V_{IN} - (V_{SW} + V_L)} + \frac{I_{PK} \cdot I_{OUT}}{V_{OUT} + V_F - V_{IN}} \right) \quad \text{eq. 12}$$

where V_L is the voltage drop across the inductor, V_F is the forward voltage of the output catch diode, and V_{SW} is the voltage drop across the power switch. $V_L + V_{SW}$ can be approximated at 0.4V and V_F can be approximated at 0.4V.

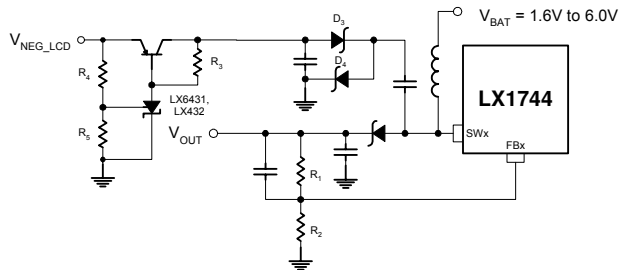
APPLICATION NOTE
NEGATIVE LCD BIAS GENERATION

For applications that require it, a negative bias can be easily generated using an inductorless charge pump consisting of only four additional discrete components (Figure 8).


Figure 8 – Negative Bias Generation

This negative output is a mirror of the positive output voltage. However, it is unregulated.

If a regulated negative bias is desired then this is also possible with some additional components. A low current shunt regulator (LX6431 or LX432) and a bipolar pass element can form a simple negative voltage LDO (Figure 9).


Figure 9 – Regulated Negative Bias

R_3 is sized to meet the minimum shunt current required for regulation while R_4 and R_5 are calculated. If R_5 is selected to be 100k Ω then R_4 is calculated using the following equation:

$$V_{\text{NEG_LCD}} = V_{\text{REF}} \cdot \left(1 + \frac{R_4}{R_5} \right) \quad \text{eq. 13}$$

where V_{REF} is a -2.5V in the case of the LX6431.

FEED-FORWARD CAPACITANCE

Improved efficiency and ripple performance can be

achieved by placing a feed-forward capacitor across the feedback resistor connected to the LCD Bias output (Figure 2). A recommended value of 1nF should be used.

PCB LAYOUT

Minimizing trace lengths from the IC to the inductor, diode, input and output capacitors, and feedback connection (i.e. pin 3) are typical considerations. Moreover, the designer should maximize the DC input and output trace widths to accommodate peak current levels associated with this circuit.

EVALUATION BOARD
Table 1: Input and Output Pin Assignments

Name	Input/Output Range	Description
VIN	0 to 6V	Main power supply for outputs.
GNDx	0V	Common ground reference.
ADJ	0 to VIN-100mV	Apply a DC voltage or a PWM voltage to this pin to adjust the LCD1 output voltage. PWM inputs should be greater than 120Hz.
SHDN	0 to VIN	Pulled up to VIN on board (10K Ω), Ground to inhibit the LED driver output (VOUT).
SHDN		Pulled up to VIN on board (10K Ω), Ground to inhibit the VLCD1.
VLCD	$\leq 25V$	Output voltage test point. Programmed for 18V output, adjustable up to 25V.
-VLCD	$\geq -25V$	Output voltage mirror of VLCD1
VOUT	$\leq 25V$	LED drive voltage probe point.
LFB	0 to VIN	LED current sense feedback.
BRT	0 to 350mV	Apply a DC voltage or a PWM voltage to this pin to adjust the LED current. PWM inputs should be greater than 120Hz with a DC portion less than 350mV.
DRV	0 to VIN	LED Driver MOSFET Gate Driver Output
REF	1.19V Typ.	Buffered IC reference output.

Note: All pins are referenced to ground.

EVALUATION BOARD
Table 3: Jumper Position Assignments

Jumper	Position	Function
J1	N/A	Close to adjust LED current with on-board potentiometer.
J2	N/A	Close to adjust VLCD with on-board potentiometer.
J3	N/A	Remove the factory installed jumper and insert a 4~6cm wire loop (optional) to observe the inductor current waveform using a current probe.
J4	N/A	Remove jumper to test open-circuit over-voltage protection implemented with R1 and R2

Note: All pins are referenced to ground.

Table 4: Factory Installed Component List

Ref	Part Description
C1	CAPACITOR, 4.7 μ F, 1210, 6.3V
C2, C7	CAPACITOR, 4.7 μ F, 1210, 35V
C3, C4	CAPACITOR, 1000pF, 0805, 35V
C5, C6	CAPACITOR, (SPARE), See Note 1
C8, C9	CAPACITOR, 1 μ F, 0805, 35V
C10, C12	CAPACITOR, 0.1 μ F, 0805, 6.3V
C11	CAPACITOR, 2.2 μ F, 0805, 16V
CR1, CR2, CR3, CR4	Microsemi UPS5819, SCHOTTKY, 1A, 40V, POWERMITE
LED1, LED2, LED3, LED4	Microsemi UPWLEDxx, LED, Optomite
L1, L2	INDUCTOR, 47 μ H, 480mA, SMT
Q1	FDV303N MOSFET, 30V, SOT-23
R1, R3	RESISTOR, 1M, 1/16W, 0805
R2, R6	RESISTOR, 75K, 1/16W, 0805
R4	RESISTOR, 1K, 1/16W, 0805
R5	RESISTOR, 15, 1/16W, 0805
R7, R8	RESISTOR, 100K, POT, 1/16W, 0805
R9, R10	RESISTOR, 100K, 1/16W, 0805
R11, R12, R13	RESISTOR, 10K, 1/16W, 0805
U1	Microsemi LX1744CPW BOOST CONTROLLER

Notes

1. Use these locations to insert additional input and/or output capacitance.

EVALUATION BOARD

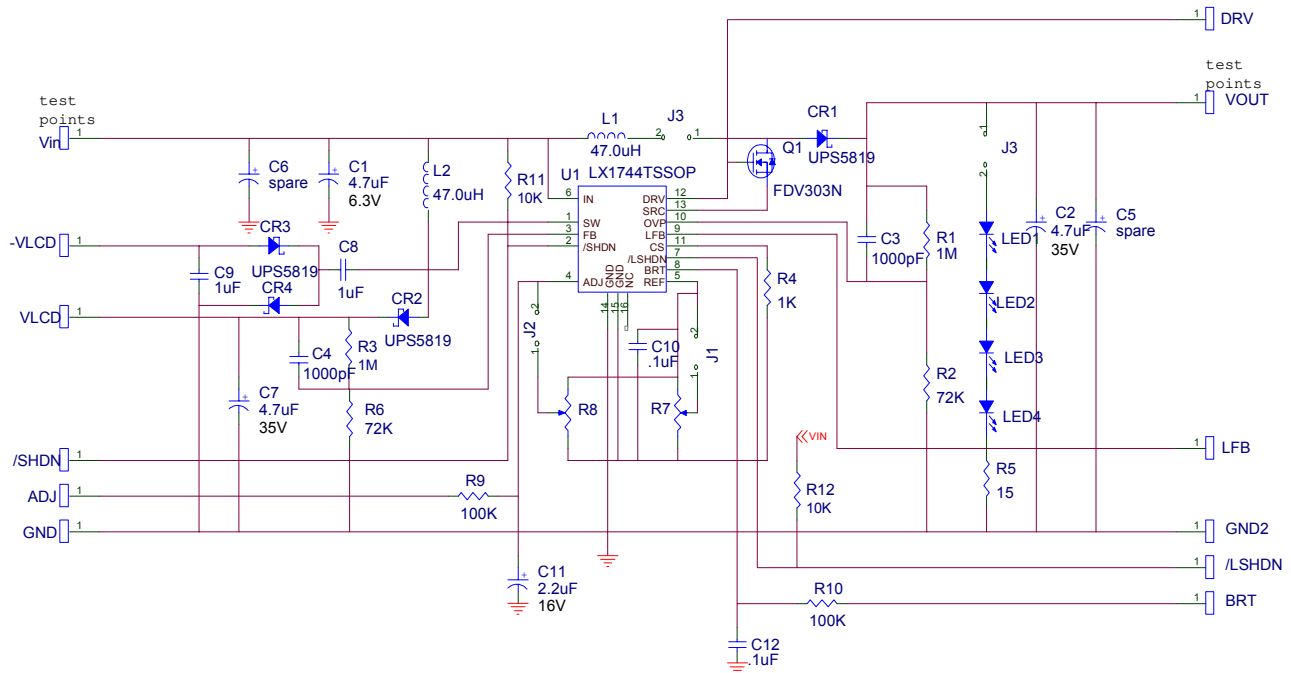
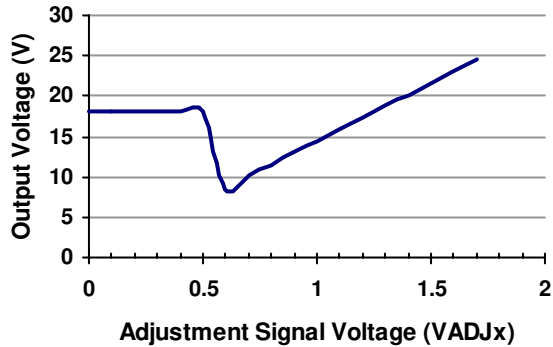
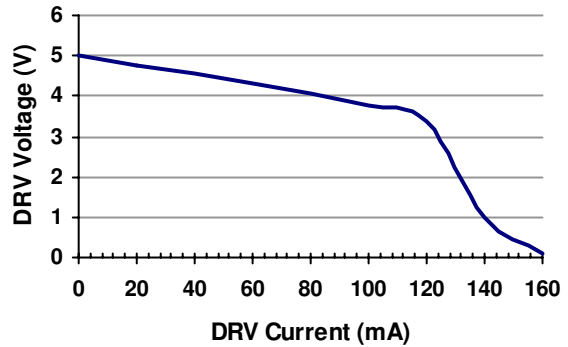


Figure 10 – LX1744EVAL Evaluation Board Schematic

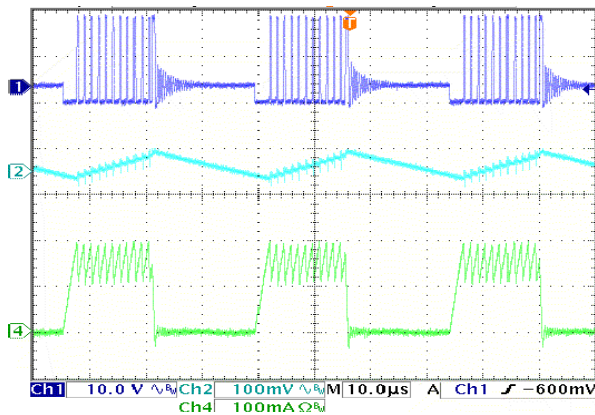


VOUT VERSUS VADJ

Figure 10 – Output Voltage Vs. Adjustment Signal Threshold

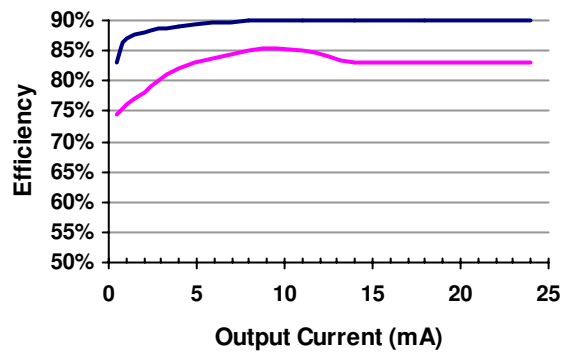
Note: The LX1744 uses the internal voltage reference until the VADJ signal exceeds 0.5V (typ).

GATE DRIVE

Figure 11 – Gate Drive Voltage Vs. Drive Current

$V_{IN} = 5V$, $T_A = 25^\circ C$

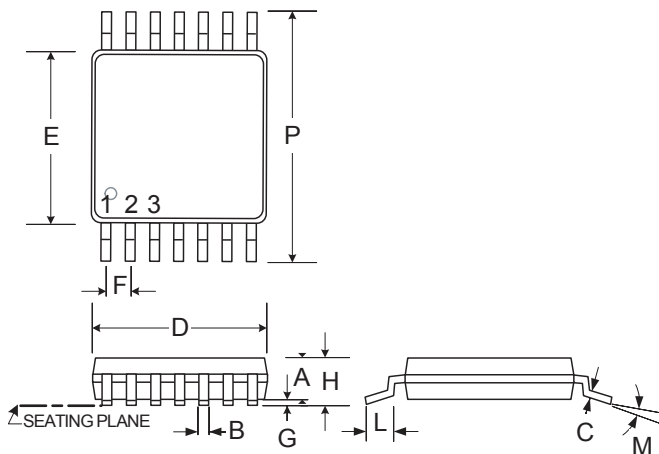
WAVEFORM

Figure 12 – Typical Switching Waveform

CH1 – SWx Voltage, **CH2** – Output Voltage, **CH3** – Inductor Current
 $V_{IN} = 3.6V$, $V_{OUT} = 18V$, $I_{OUT} = 9mA$

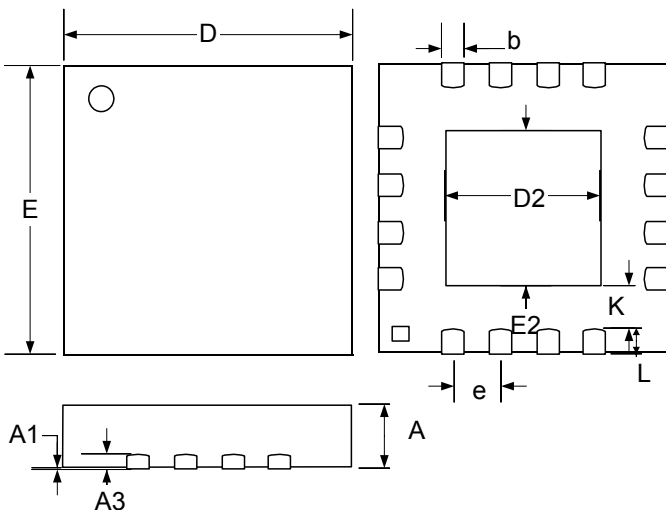
EFFICIENCY

Figure 13 – LED Driver (Upper) and LCD Bias Efficiency

$V_{IN} = 5V$, Four LEDs, $L = 47\mu H$, $R_{CS} = 4k\Omega$

$V_{IN} = 3.6V$, $V_{OUT} = 5.5V$, $L = 47\mu H$

PACKAGE DIMENSIONS
PW 14-Pin Thin Small Shrink Outline Package (TSSOP)


DIM	MILLIMETERS		INCHES	
	MIN	MAX	MIN	MAX
A	0.85	0.95	0.033	0.037
B	0.17	0.27	0.007	0.011
C	0.09	0.20	0.004	0.008
D	4.90	5.10	0.193	0.201
E	4.30	4.50	0.169	0.177
F	0.65 BSC		0.026 BSC	
G	0.05	0.15	0.002	0.006
H	-	1.10	-	0.043
L	0.45	0.75	0.0177	0.030
M	0°	8°	0°	8°
P	6.4 BSC		0.252 BSC	
*LC	-	0.10	-	0.004

LQ 16-Pin Micro Leadframe Package - Quad Package (MLPQ)


DIM	MILLIMETERS		INCHES	
	MIN	MAX	MIN	MAX
A	0.80	1.00	0.031	0.039
A1	0	0.05	0	0.002
A3	0.18	0.30	0.007	0.012
b	0.23	0.38	0.009	0.015
D	4.00 BSC		0.157 BSC	
E	4.00 BSC		0.157 BSC	
e	0.65 BSC		0.026 BSC	
D2	2.55	2.80	0.100	0.110
E2	2.55	2.80	0.100	0.110
K	0.20	-	0.008	
L	0.30	0.50	0.012	0.020

Note: Dimensions do not include mold flash or protrusions; these shall not exceed 0.155mm(.006") on any side. Lead dimension shall not include solder coverage.

NOTES

PRODUCTION DATA – Information contained in this document is proprietary to Microsemi and is current as of publication date. This document may not be modified in any way without the express written consent of Microsemi. Product processing does not necessarily include testing of all parameters. Microsemi reserves the right to change the configuration and performance of the product and to discontinue product at any time.