



OMNI® LINE VOLTAGE ACOUSTIC AND PIR CEILING SENSOR

CEILING MOUNT OCCUPANCY SENSORS

FEATURES

- IntelliDAPT® self-adaptive technology—no manual adjustment required
- All-digital dual technology acoustic and passive infrared (PIR) sensor
- Non-volatile memory for sensor settings
- 450 square-foot coverage
- Self-contained power supply
- Universal voltage (100-277VAC; 50/60 Hz)
- UL and cUL listed
- California Title 24 compliant
- 5 year warranty



RELATED PRODUCTS

[Occupancy Sensor Accessories](#)

SPECIFICATIONS

CONSTRUCTION

- Ø4.5", 3.4" H (Ø114mm, 86.4mm H)
- 8.2 oz (232g)
- Off-white
- Casing—rugged, high-impact, injection-molded plastic KJB ABS
- Cicolac (UL-945VA) flame class rating, UV inhibitors
- Color-coded leads are 6" long (152.4mm)
- Dual-element pyrometer and 12-element cylindrical rugged lens
- Red LED lamp - infrared motion
- Green LED lamp - acoustic detection

INSTALLATION

- Mounting base provided
- Recommended MAX mounting height: 12ft. (3.66m)

ELECTRICAL

- 100-277VAC; 50/60Hz
- 20A: 120 VAC Incandescent

ELECTRICAL (CONTINUED)

- 20A: 120 or 277VAC Magnetic Ballast
- 16A: 120 or 277VAC Electronic Ballast
- 1HP: 120VAC Motor Load
- 1HP: 277VAC Motor Load

OPERATION

- IntelliDAPT
 - Auto reset from test setting
 - Self-adjusting timer
 - Self-adjusting passive infrared thresholds
 - Automatic false-ON/false-OFF corrections
- Coverage
 - Coverage: 450 square feet (137.16 square meters)
- Timer Settings
 - Automatic mode: 8-30 min. (self-adjusts based on occupancy)
 - Test mode: 8 seconds (for an easy check at installation)

OPERATING ENVIRONMENT

- Indoor use only
- Operating temperature: 32° to 104°F (0° to 40°C)
- Relative humidity (non-condensing): 0% to 95%

CERTIFICATIONS

- UL and cUL listed
- California Title 24 compliant

WARRANTY

- 5 year warranty
- See [HLI Standard Warranty](#) for additional information

ORDERING GUIDE

Example: OMNIDIABP1277

CATALOG #

OMNIDIABP1277

MODEL

OMNIDIABP1277 Line Voltage Dual Technology Acoustic and Passive Infrared Ceiling Sensor, 450 sq ft coverage

*When used with program start ballast, a 1-2 second delay from occupancy detection to lamp turn-on may be experienced

OMNI® LINE VOLTAGE ACOUSTIC AND PIR CEILING SENSOR

CEILING MOUNT OCCUPANCY SENSORS

DIMENSIONS

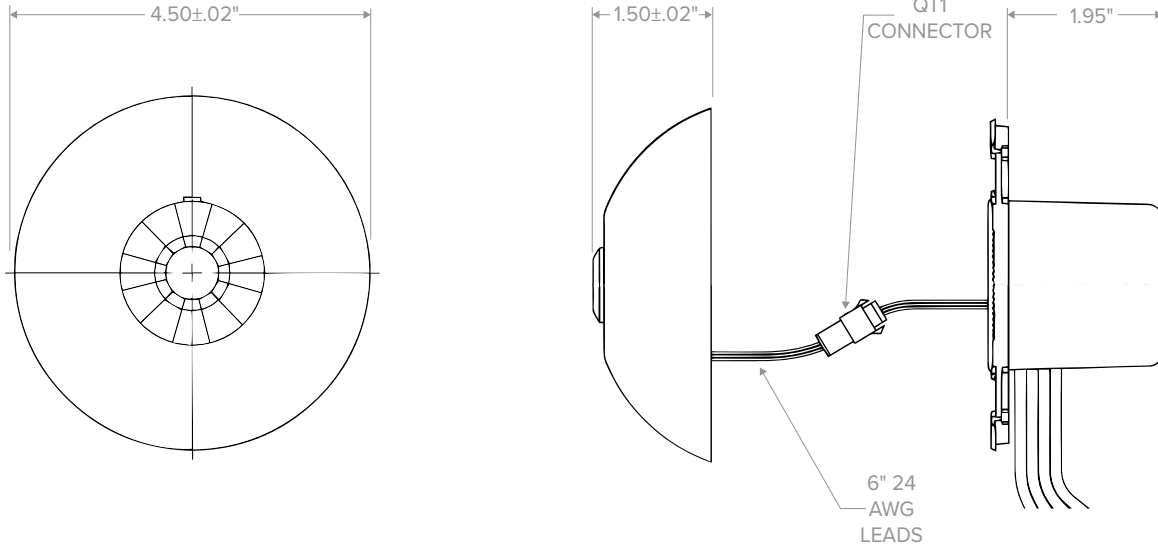

ADDITIONAL INFORMATION

Coverage Pattern

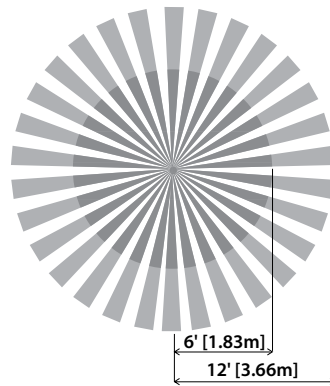

- Minor Motion
- Major Motion

DIA Range

Wiring Diagram

