

PART NUMBER	REV	FIRST USED	FEED TYPE
567436-1	B	LEADMAKER	MECH
567436-2	B	AMP-0-ELECTRIC	MECH

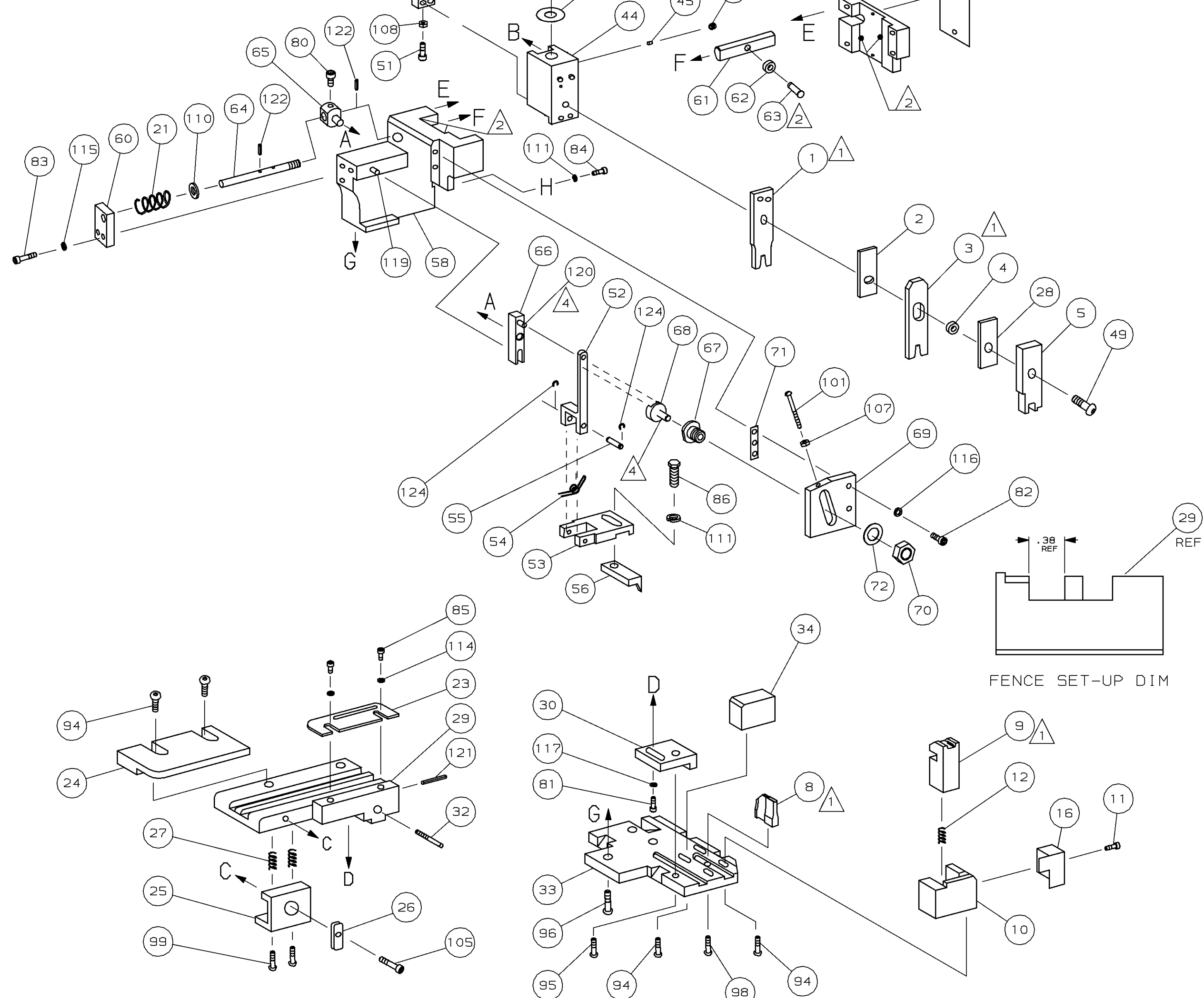

FENCE SET-UP DIM

* Trademark of AMP Incorporated

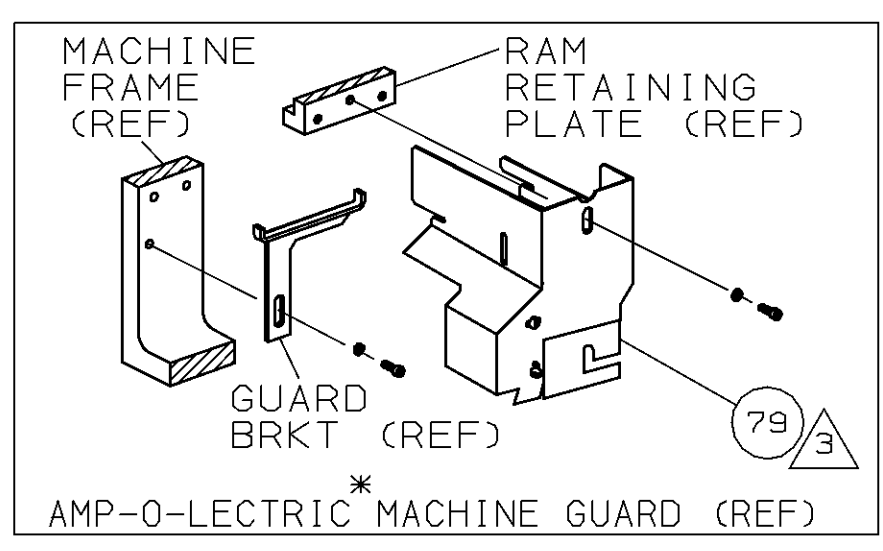
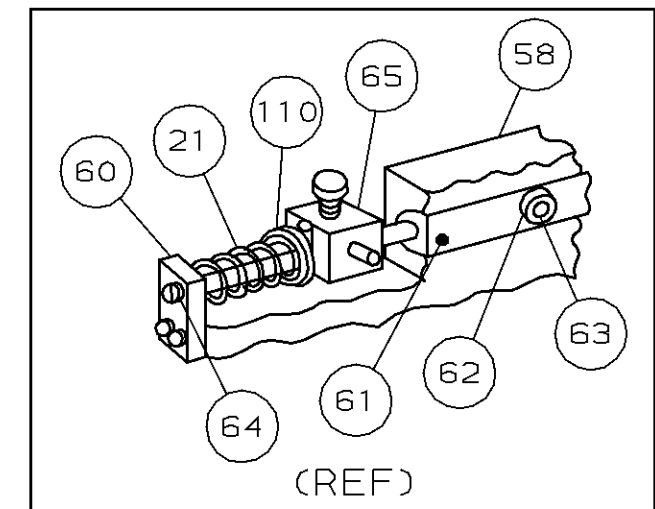
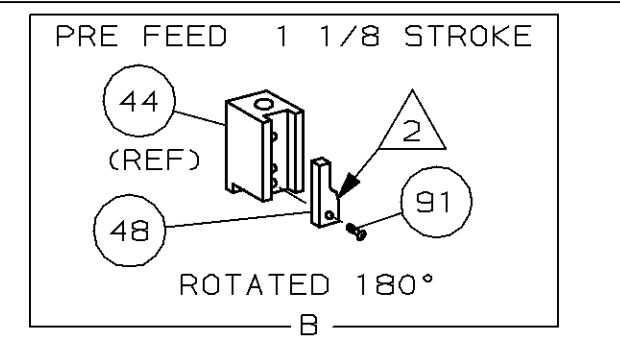
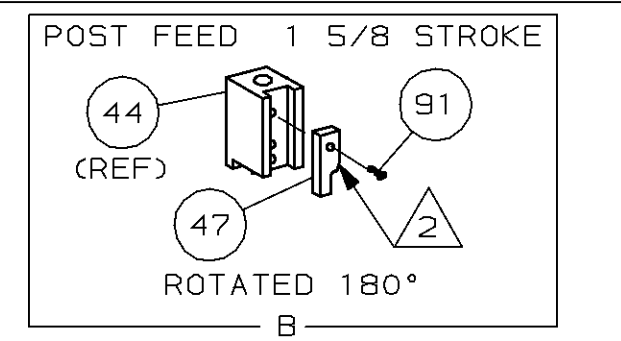

CRIMPING DATA

PAD LTR	CRIMP HEIGHT	WIRE SIZE	WIRE STRIP LENGTH
A	.057	15 1/2	
B	.054	17	
C	.053	18 1/2	
D	.051	20	

CRIMP	SIZE	TYPE	FEED	APPL INST
WIRE	.090	F	.801	AI 8040
INSUL	.140	F		

WIRE RANGE	INSULATION RANGE	SET UP GAGE	LAYOUT
20-15 1/2	.091-.130	458637-1	L1439

TERMINAL NAME: STANDARD-TIMER CONTACT

LOC	DIST	WIRE	INSUL	WIRE RANGE	INSULATION RANGE	SET UP GAGE	LAYOUT
A	66	.090	F	20-15 1/2	.091-.130	458637-1	L1439

- 1 RECOMMENDED SPARE PARTS.
 - 2 GREASE LIGHTLY.
 - 3 GUARD MUST BE IN PLACE WHEN OPERATING APPLICATOR IN AMP-0-ELECTRIC MACHINE.
 - 4 LUBRICATE DAILY USING NO. 20 MACHINE OIL.
5. ITEMS WITH QTY OF REF SPECIFIED (EXCEPT ITEM 79) ARE USED ON ITEM 46.

QTY	REF	DESCRIPTION	ITEM NO
130			
129			
128			
127			
126			
125			
124	REF REF - A	21045-3 RING,RET "C" (Ø.187)FD FING PIN	
123			
122	REF REF - A	5-21028-1 PIN,SLT SPR(Ø.125x.50)ADJ ROD	
121	1 1 - A	4-21028-0 PIN,SLT SPR(Ø.093x.75)ST GDE PL	
120	REF REF - A	1-21030-1 PIN,DOWEL (Ø.187x.50)LEVER	
119	REF REF - A	1-21030-6 PIN,DOWEL (Ø.187x1.25)HOUSING	
118			
117	1 1 - A	21024-5 WASHER, LOCK (#10)ADJ BLOCK	
116	REF REF - A	21024-5 WASHER,LOCK (#10)ADJ PLATE	
115	REF REF - A	21024-5 WASHER,LOCK (#10)FEED GDE ROD	
114	2 2 - A	21024-2 WASHER,LOCK (#4)FRONT STP GUIDE	
113			
112			
111	4 4 - A	21024-4 WASHER,LOCK (#8)STRIPPER	
110	REF REF - A	21899-4 WASHER,FLAT (Ø5/16)SCREW ADJ	
109			
108	1 1 - A	21018-5 NUT, HEX (NO. 6)HOLDDOWN	
107	REF REF - A	21018-5 NUT, HEX (6-32)FEED ADJ	
106			
105	1 1 - A	22353-8 SCR,SHLD (Ø.187x.25)DRAG LEVER	
104	1 - A	456567-1 SCR,SHLD (Ø.188x.12)STRIP	
103	1 1 - A	21009-2 SCR,SKT SET (1/4-20x.25 LW)RAM	
102	2 2 - A	21017-2 SCR,DRIVE (#2x.19)ID PLATE	
101	REF REF - A	6-23715-5 SCR,PAN HD (6-32x1.50)FEED ADJ	
100	1 1 - B	461264-1 PLATE, IDENTIFICATION	
99	2 2 - A	2-21002-9 SCR,BHC (10-32x.75)DRAG	
98	1 1 - A	22733-8 SCR,BHC (8-32x.38 LW)ANVIL	
97	REF REF - A	2-21002-9 SCR,BHC (10-32x.75)CAP	
96	REF REF - A	2-22733-8 SCR,BHC (1/4-20x.62)HOUSING	
95	REF REF - A	2-21002-7 SCR,BHC (10-32x.50)SG ADJ BLOCK	
94	6 6 - A	2-21002-2 SCR,BHC (8-32x.50)SHEAR	
93			
92			
91	1 1 - A	1-21002-7 SCR,BHC (6-32x.38)CAM	
90			
89			
88			
87			
86	1 1 - A	2-22603-0 SCR,HEX HD (8-32x.31)FEED FINGER	
85	2 2 - A	1-21000-3 SCR,SHC (4-40x.25)F ST GUIDE	
84	3 3 - A	2-21000-7 SCR,SHC (8-32x.50)STRIPPER	
83	REF REF - A	3-21000-7 SCR,SHC (10-32x.75)FEED ROD GD	
82	REF REF - A	3-21000-6 SCR,SHC (10-32x.62)FD ADJ BLK	
81	1 1 - A	3-21000-4 SCR,SHC (10-32x.38)SG ADJ BL	
80	REF REF - A	3-21000-4 SCR,SHC (10-32x.38)PIVOT BLK	
79	REF - B	455749-1 GUARD, WINDOW	
78			
77			
76			
75			
74	2 2 - A	690603-1 SPRING, ASSIST	
73	2 2 - A	23030-1 SCR,SHC (6-32x.25)CP DISC	
72	REF REF - A	458109-1 WASHER, SPECIAL	
71	REF REF - A	690517-1 SPACER	

REF	REF	QTY	DESCRIPTION	ITEM NO
REF	REF	- B	22594-8 NUT,HEX (1/2-20)	70
REF	REF	- B	240628-1 PLATE, ADJUSTMENT	69
REF	REF	- B	240626-1 SHAFT, PIVOT	68
REF	REF	- B	240633-1 BUSHING	67
REF	REF	- A	455680-1 LEVER, INTERMEDIATE	66
REF	REF	- B	240629-1 BLOCK, PIVOT	65
REF	REF	- A	240632-2 SCREW, ADJ FEED ROD	64
REF	REF	- B	240659-3 PIN, CAM ROLLER	63
REF	REF	- B	240658-1 ROLLER, CAM	62
REF	REF	- B	454398-2 ROD, FEED	61
REF	REF	- A	454178-1 GUIDE, FEED ROD	60
REF	REF	- C	454220-1 CAP, RAM	59
REF	REF	- D	454485-1 HOUSING	58
				57
1	1	- B	458537-2 PAWL, FEED	56
REF	REF	- B	240624-1 PIN, FEED FINGER	55
REF	REF	- B	691499-1 SPRING, FEED FINGER	54
REF	REF	- B	690541-1 HOLDER, FEED FINGER	53
REF	REF	- A	455679-1 LEVER, TERMINAL FEED ARM	52
1	1	- A	811242-2 BUMPER, HOLDDOWN	51
1	1	- A	690753-1 SPACER, TONKER	50
1	1	- A	7-21002-9 BOLT, CRIMPER (5/16x1.00)	49
1	-	- B	690602-5 CAM, PRE-FEED 1 1/8 ST	48
-	1	- B	690501-4 CAM, POST-FEED 1 5/8 ST	47
1	1	- B	459456-1 APPLICATOR, BASIC (SUBASSY)	46
1	1	- A	690191-1 PLUG, NYLON	45
1	1	- C	455673-1 RAM	44
1	1	- A	690125-1 WASHER, LAMINATED	43
1	1	- A	690124-1 WASHER, RAM	42
				41
2	2	- A	23241-6 BALL, STEEL	40
2	2	- A	690170-1 SPRING, COMPRESSION	39
1	1	- C	690142-1 DISC, INSULATION	38
1	1	- B	690692-7 DISC, WIRE	37
1	1	- A	22480-5 WASHER, SPRING	36
1	1	- B	690212-1 POST, RAM	35
1	1	- B	690786-1 SUPPORT, TERMINAL	34
REF	REF	- D	455675-1 PLATE, BASE	33
1	1	- A	690432-3 SCREW, ADJUSTMENT	32
				31
REF	REF	- B	455689-1 BLOCK, STRIP GUIDE ADJ	30
1	1	- C	843869-1 PLATE, STRIP GUIDE	29
1	1	- C	1-455888-6 SPACER, FRONT SHEAR DEP	28
2	2	- A	1-22284-0 SPRING, DRAG	27
1	1	- B	240793-1 LEVER, DRAG RELEASE	26
1	1	- B	240792-1 DRAG, TERMINAL	25
1	1	- D	7-690504-6 GUIDE, STRIP (REAR)	24
1	1	- A	690438-1 GUIDE, STRIP (FRONT)	23
-	1	- B	690472-2 STRIPPER	22
REF	REF	- A	4-22284-9 SPRING, FEED RETURN	21
1	-	- B	458950-1 STRIPPER, WIRE STOP	20
1	-	- B	458949-1 STRIPPER	19
				18
				17
1	1	- B	691667-3 GUARD, CHIP (FRONT)	16
				15
				14
				13
1	1	- A	5-22280-0 SPRING, SHEAR	12
1	1	- B	690461-1 STOP, SHEAR	11
1	1	- C	690459-1 HOLDER, SHEAR (FRONT)	10
1	1	- C	454276-1 SHEAR, FLOAT (FRONT)	9
1	1	- C	2-854014-9 ANVIL	8
				7
				6
1	1	- C	1-455889-4 DEPRESSOR, SHEAR (FRONT)	5
1	1	- B	1-238011-0 SPACER, BLOCK CRIMPER	4
1	1	- C	3-456134-2 CRIMPER, INSULATION	3
1	1	- C	455888-4 SPACER, CRIMPER	2
1	1	- C	3-456406-3 CRIMPER, WIRE	1

THIS DRAWING IS A CONTROLLED DOCUMENT FOR AMP INCORPORATED. IT IS SUBJECT TO CHANGE AND THE CONTROLLING ENGINEERING ORGANIZATION SHOULD BE CONTACTED FOR THE LATEST REVISION.

THIS INFORMATION IS CONFIDENTIAL AND IS DISCLOSED TO YOU ON CONDITION THAT NO FURTHER DISCLOSURE IS MADE BY YOU TO OTHER THAN AMP PERSONNEL WITHOUT WRITTEN AUTHORIZATION FROM AMP INCORPORATED, HARRISBURG, PA.