

PART NUMBER	REV	FIRST USED
680659-1	A	122500-1
680659-2	A	565435-5
680659-3	A	354500-1

OBSOLETE
OBSOLETE

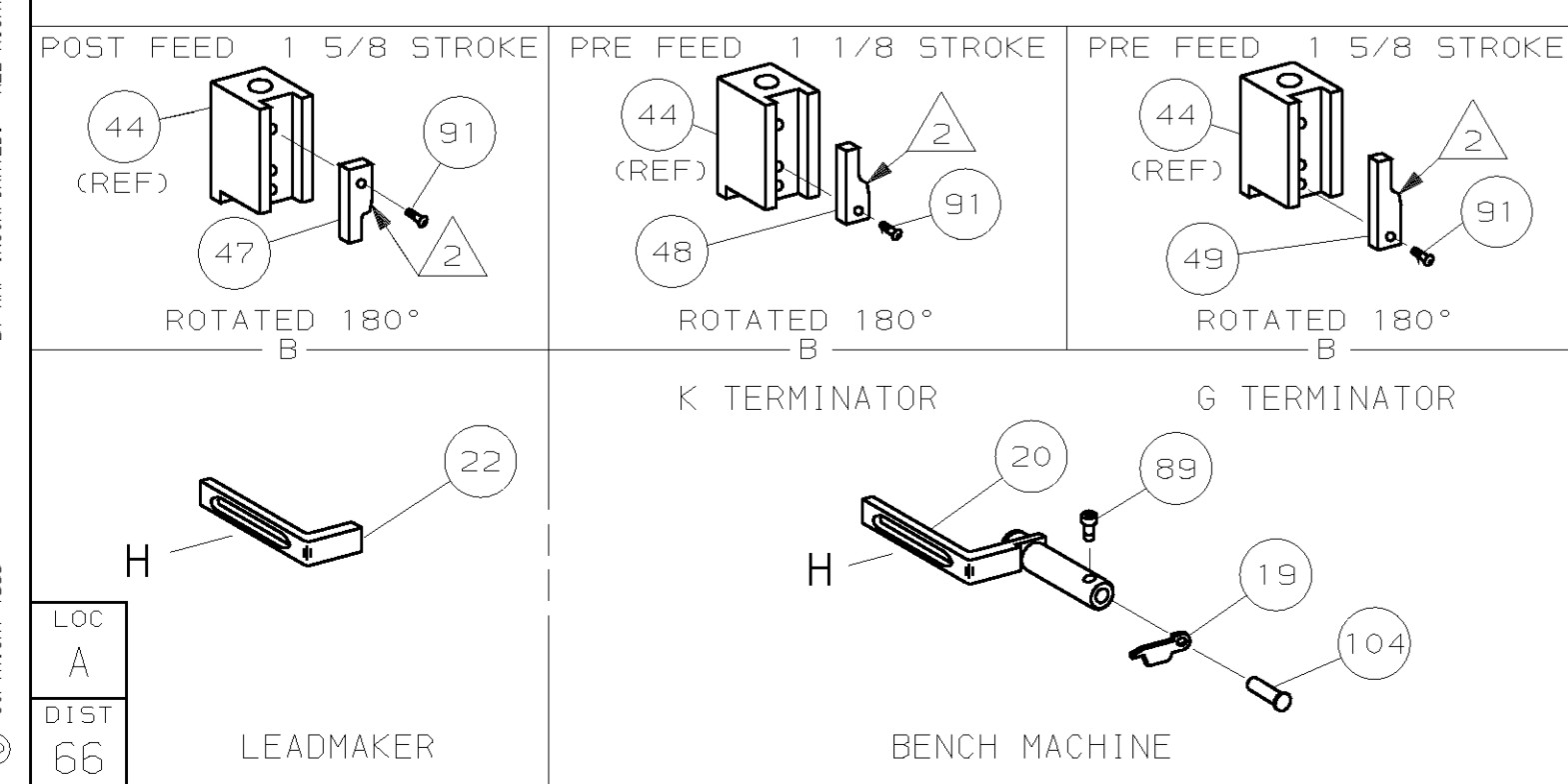
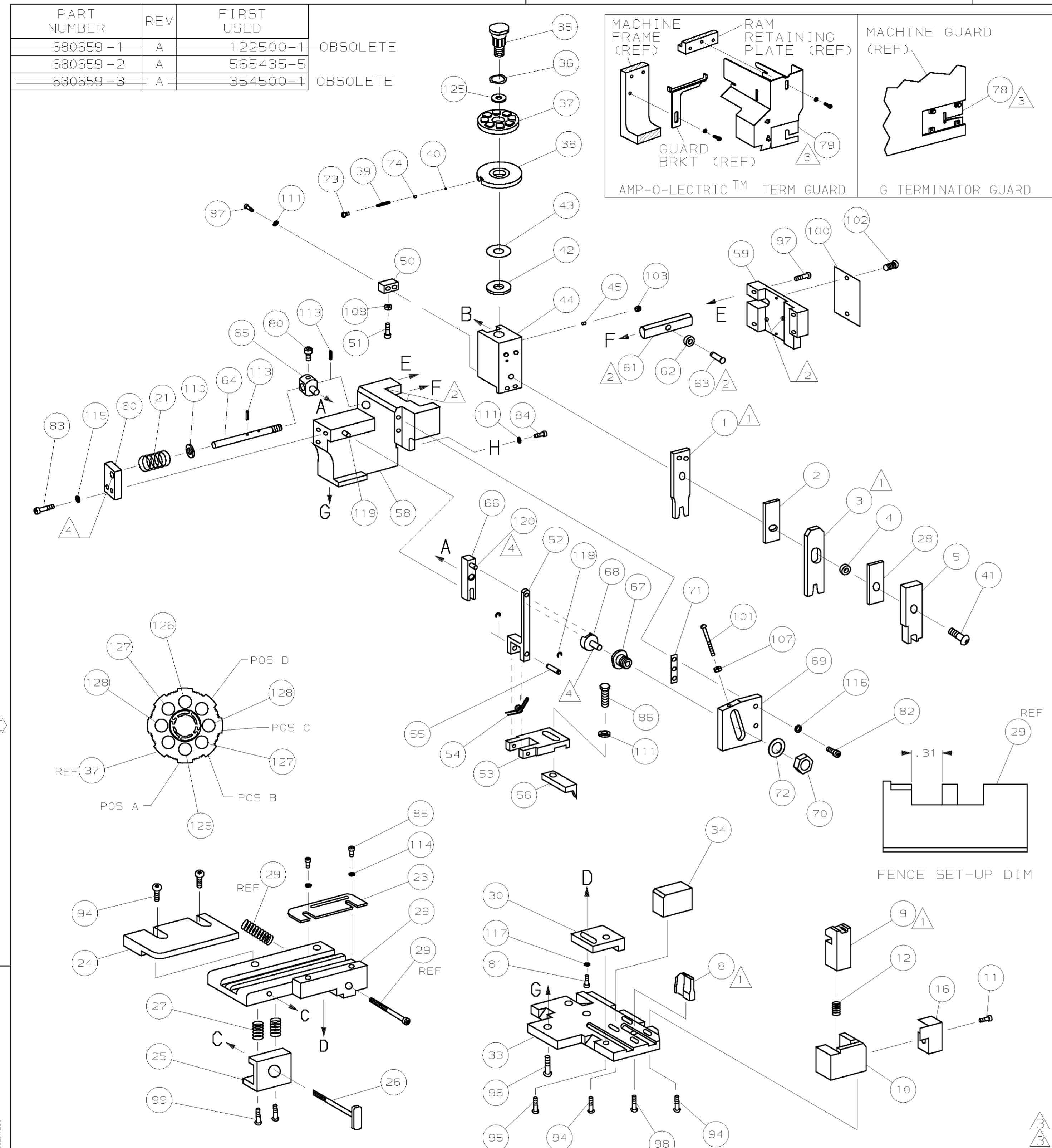

- 1 RECOMMENDED SPARE PARTS.
- 2 GREASE LIGHTLY.
- 3 GUARD MUST BE IN PLACE WHEN OPERATING APPLICATOR IN A BENCH MACHINE.
- 4 LUBRICATE DAILY USING NO. 20 MACHINE OIL.
- 5. ITEMS WITH QTY OF REF SPECIFIED (EXCEPT ITEMS 78 AND 79) ARE USED ON ITEM 46.

CRIMP DATA (AMP TERMINAL)			
PAD LTR	CRIMP HEIGHT	WIRE SIZE	
A	.023 ± .002 [0.58 ± 0.05mm]	28	
B	.022 ± .002 [0.56 ± 0.05mm]	30	
C	.021 ± .002 [0.53 ± 0.05mm]	32	
D	NOT	USED	
CRIMP	SIZE	TYPE	RANGE
WIRE	.033 [0.84mm]	F	32-28
INSUL	.055 [1.40mm]	F	∅.030-.040

QTY	REF	REF	REF	U/M	DWG SIZE	PART NO	DESCRIPTION	ITEM NO
2	2	2	-	C		7-354779-5	PIN, WIRE DISC (.3365)C	129
2	2	2	-	C		7-354779-2	PIN, WIRE DISC (.3350)B	127
2	2	2	-	C		7-354779-1	PIN, WIRE DISC (.3345)A	126
1	1	-	-	A		986950-1	WASHER, FLAT PRECISION	125
1	1	-	-	A		217238-1	GENERAL INSTRUCTION PACKAGE	124
1	1	-	-	-		4088040	SF APPL INST 408-8040	123
REF	REF	REF	-	A		1-21030-1	PIN, DOWEL (∅.187x.50) LEVER	120
REF	REF	REF	-	A		1-21030-6	PIN, DOWEL (∅.187x1.25) HOUSING	119
REF	REF	REF	-	A		21045-3	RING, RET "C" (∅.187) FD FING PIN	118
1	1	-	-	A		21024-5	WASHER, LOCK (#10) ADJ BLOCK	117
REF	REF	REF	-	A		21024-5	WASHER, LOCK (#10) ADJ PLATE	116
REF	REF	REF	-	A		21024-5	WASHER, LOCK (#10) FEED GDE ROD	115
2	2	2	-	A		21024-2	WASHER, LOCK (#4) FRONT STP GUIDE	114
REF	REF	REF	-	A		5-21028-1	PIN, SLT 5PR (∅.125x.50) ADJ ROD	113
4	4	4	-	A		21024-4	WASHER, LOCK (#8) STRIPPER	112
REF	REF	REF	-	A		21899-4	WASHER, FLAT (∅5/16) SCREW ADJ	110
1	1	-	-	A		21018-5	NUT, HEX (NO. 6) HOLDDOWN	108
REF	REF	REF	-	A		21068-5	NUT, HEX (6-32) FEED ADJ	107
1	1	-	-	A		992031-1	PIN, CLEVIS	105
1	1	-	-	A		21009-2	SCR, SKT 5ET (1/4-20x.25 LW) RAM	103
2	2	2	-	A		21017-2	SCR, DRIVE (#2x.19) ID PLATE	102
REF	REF	REF	-	A		6-23715-5	SCR, PAN HD (6-32x1.50) FEED ADJ	101
1	1	-	-	B		461264-1	PLATE, IDENTIFICATION	100
2	2	2	-	A		3-21002-0	SCR, BHC (10-32x.88) DRAG	99
1	1	-	-	A		22733-8	SCR, BHC (8-32x.38 LW) ANVIL	98
REF	REF	REF	-	A		2-21002-9	SCR, BHC (10-32x.75) CAP	97
REF	REF	REF	-	A		2-22733-8	SCR, BHC (1/4-20x.62) HOUSING	96
REF	REF	REF	-	A		2-21002-7	SCR, BHC (10-32x.50) 56 ADJ BLOCK	95
6	6	6	-	A		2-21002-2	SCR, BHC (8-32x.50) TERM H DWN	94
1	1	-	-	A		1-21002-7	SCR, BHC (6-32x.38) CAM	91
1	1	-	-	A		7-21000-9	SCR, SHC (4-40x.19) STRIPPER	90
2	2	2	-	A		2-21000-7	SCR, SHC (8-32x.62) HOLD DOWN	87
1	1	-	-	A		2-22603-0	SCR, HEX HD (8-32x.31) FEED FINGER	86
2	2	2	-	A		1-21000-3	SCR, SHC (4-40x.25) F ST GUIDE	85
1	1	-	-	A		2-21000-7	SCR, SHC (8-32x.50) STRIPPER	84
REF	REF	REF	-	A		3-21000-7	SCR, SHC (10-32x.75) FEED ROD 6D	83
REF	REF	REF	-	A		3-21000-6	SCR, SHC (10-32x.62) FD ADJ BLK	82
1	1	-	-	A		3-21000-4	SCR, SHC (10-32x.38) 56 ADJ BL	81
REF	REF	REF	-	A		3-21000-4	SCR, SHC (10-32x.38) PIVOT BLK	80
-	REF	-	-	B		455749-1	GUARD, WINDOW	79
REF	-	-	-	B		679532-1	INSERT, GUARD	78
1	1	-	-	A		690603-1	SPRING, ASSIST	74
1	1	-	-	A		23030-1	SCR, SHC (6-32x.25 SL) INS DISC	73
REF	REF	REF	-	A		458109-1	WASHER, SPECIAL	72
REF	REF	REF	-	A		690517-1	SPACER	71

QTY	REF	REF	REF	U/M	DWG SIZE	PART NO	DESCRIPTION	ITEM NO
-1						LEADMAKER	MECH POST FEED	OBSOLETE
-2						BENCH MODEL K	MECH PRE FEED	OBSOLETE
-3						BENCH MODEL G	MECH PRE FEED	OBSOLETE
REF	REF	REF	-	B		22594-8	NUT, HEX (1/2-20)	70
REF	REF	REF	-	B		240628-1	PLATE, ADJUSTMENT	69
REF	REF	REF	-	B		240626-1	SHAFT, PIVOT	68
REF	REF	REF	-	B		240633-1	BUSHING	67
REF	REF	REF	-	A		455680-1	LEVER, INTERMEDIATE	66
REF	REF	REF	-	B		240629-1	BLOCK, PIVOT	65
REF	REF	REF	-	A		240632-2	SCREW, ADJ FEED ROD	64
REF	REF	REF	-	B		240659-3	PIN, CAM ROLLER	63
REF	REF	REF	-	B		240658-1	ROLLER, CAM	62
REF	REF	REF	-	B		454398-2	ROD, FEED	61
REF	REF	REF	-	A		454178-1	GUIDE, FEED ROD	60
REF	REF	REF	-	C		454220-1	CAP, RAM	59
REF	REF	REF	-	D		454485-1	HOUSING	58
1	1	-	-	B		690542-2	PAWL, FEED	56
REF	REF	REF	-	B		240624-1	PIN, FEED FINGER	55
REF	REF	REF	-	B		691499-1	SPRING, FEED FINGER	54
REF	REF	REF	-	B		690541-1	HOLDER, FEED FINGER	53
REF	REF	REF	-	A		455679-1	LEVER, TERMINAL FEED ARM	52
REF	REF	REF	-	A		811242-2	BUMPER, HOLDDOWN	51
1	1	-	-	A		690753-1	SPACER, TONKER	50
-	-	-	-	B		690602-6	CAM, PRE-FEED 1 5/8 ST	49
-	-	-	-	B		690602-5	CAM, PRE-FEED 1 1/8 ST	48
-	-	-	-	B		690501-4	CAM, POST-FEED 1 5/8 ST	47
1	1	-	-	B		459456-1	APPLICATOR, BASIC (SUBASSY)	46
1	1	-	-	A		690191-1	PLUG, NYLON	45
1	1	-	-	C		455673-1	RAM	44
1	1	-	-	A		690125-1	WASHER, LAMINATED	43
1	1	-	-	A		690124-1	WASHER, RAM	42
1	1	-	-	A		7-21002-9	BOLT, CRIMPER (5/16x1.00)	41
1	1	-	-	A		23241-6	BALL, STEEL	40
1	1	-	-	A		690170-1	SPRING, COMPRESSION	39
1	1	-	-	C		690142-1	DISC, INSULATION	38
1	1	-	-	D		354777-1	WIRE DISC, PLASTIC	37
1	1	-	-	A		22480-5	WASHER, SPRING	36
1	1	-	-	B		690212-1	POST, RAM	35
1	1	-	-	B		690786-1	SUPPORT, TERMINAL	34
REF	REF	REF	-	D		455675-1	PLATE, BASE	33
1	1	-	-					32
1	1	-	-					31
REF	REF	REF	-	B		455689-1	BLOCK, STRIP GUIDE ADJ	30
1	1	-	-	C		318042-1	STRIP GUIDE PLATE ASSY	29
1	1	-	-	C		2-455888-0	SPACER, FRONT SHEAR DEP	28
2	2	2	-	A		1-22284-0	SPRING, DRAG	27
1	1	-	-	B		690546-1	LEVER, DRAG RELEASE	26
1	1	-	-	B		240792-1	DRAG, TERMINAL	25
1	1	-	-	D		6-690504-4	GUIDE, STRIP (REAR)	24
1	1	-	-	A		690438-1	GUIDE, STRIP (FRONT)	23
-	-	-	-	B		690472-2	STRIPPER	22
REF	REF	REF	-	A		4-22284-9	SPRING, FEED RETURN	21
1	1	-	-	A		679218-1	STRIPPER WIRE STOP ASSY	20
1	1	-	-	B		458949-1	STRIPPER	19
1	1	-	-					18
1	1	-	-					17
1	1	-	-	B		318563-1	GUARD, CHIP, FRONT	16
1	1	-	-					15
1	1	-	-					14
1	1	-	-					13
1	1	-	-	A		5-22280-0	SPRING, SHEAR	12
1	1	-	-	B		690461-1	STOP, SHEAR	11
1	1	-	-	C		690459-1	HOLDER, SHEAR (FRONT)	10
1	1	-	-	C		462006-1	SHEAR, FLOAT (FRONT)	9
1	1	-	-	C		662181-1	ANVIL	8
1	1	-	-					7
1	1	-	-					6
1	1	-	-	C		2-455889-0	DEPRESSOR, SHEAR (FRONT)	5
1	1	-	-	B		2-238011-3	SPACER, BLOCK CRIMPER	4
1	1	-	-	C		5-683453-2	CRIMPER, INSULATION	3
1	1	-	-	C		455888-1	SPACER, CRIMPER	2
1	1	-	-	C		456400-6	CRIMPER, WIRE	1