

Proximity Sensor

E2E/E2EQ NEXT Series

DC 3-Wire

Enables easier and standardized designs previously not possible



- Exceptional sensing distance*¹. Nearly double the sensing distance of previous models.
- With high-brightness LED, indicator is visible 360° around.
- Only 10 seconds*² to replace a Proximity Sensor with the Quick fix (Mounting Sleeve).
- Cables with enhanced oil resistance have 2-year oil resistance*³.
- IP69K compliant for water resistance and wash resistance*⁴
- UL certification (UL60947-5-2)*⁵ and CSA certification (CSA C22.2 UL60947-5-2-14)
- All PNP models come standard with IO-Link



For the most recent information on models that have been certified for safety standards, refer to your OMRON website.

*1. Based on December 2018 OMRON investigation.
 *2. Time required to adjust the distance when installing a Sensor. Based on OMRON investigation.
 *3. Refer to *Ratings and Specifications* for details. However, E2E Connector Models and E2EQ series is excluded.
 *4. E2EQ series is excluded.
 *5. M8 (4-pin) Connector Models are not UL certified.

Be sure to read *Safety Precautions* on page 47.

Features

PREMIUM Model

User-friendly design

Exceptional sensing range*⁶

9 [M12] mm *⁷

- The PREMIUM Model, which has longer detection range than previous models, allows for flexible designs with lower risk of collision.
- Enables users to standardize sensors sizes to reduce inventory needs.

*6. Based on December 2018 OMRON investigation.
 *7. Quadruple distance models of M12 sized

Quadruple distance model
9mm [M12]

Triple distance model
6mm [M12]

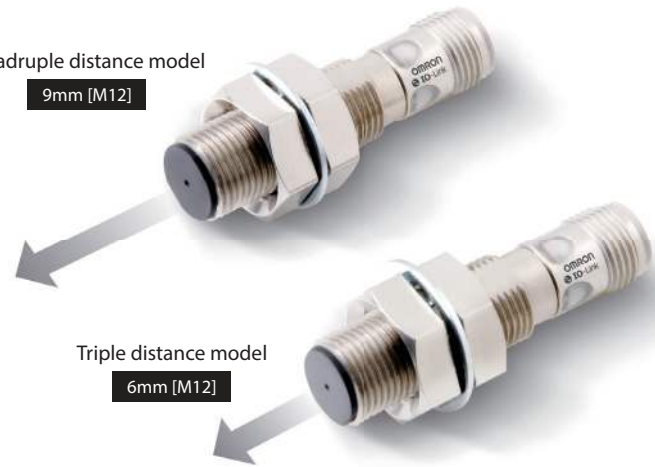

BASIC Model

In addition to our HIGH SPEC Models, we also offer mid/short-distance BASIC Models, to meet various equipment design requirement specifications.

Double distance model
4mm [M12]

Single distance model
2mm [M12]



New standards for usability

Early error detection

1 location, all new E2E Sensors can be monitored with IO-Link

Fewer unexpected equipment shutdowns

Strong resistance to cutting oil **2**-year*⁹ oil resistance*⁹

Quick recovery

10 second replaceable with quick fix (adaptor)*⁸
360° degree view with high visibility LED indicator

*8. Time required to adjust the distance when installing a Sensor. Based on OMRON investigation.

*9. E2E Connector Models and E2EQ series is excluded.

E2E/E2EQ NEXT Series

E2E/E2EQ NEXT Series Model Number Legend

DC 3-wire

E2E (1) - X (2) (3) (4) (5) (6) (7) - (8) - (9) - (10) (11)

| No. | Type | Code | Meaning |
|------|------------------------|----------|--|
| (1) | Case | Blank | Without spatter-resistant coating |
| | | Q | With spatter-resistant coating |
| (2) | Sensing distance | Number | Sensing distance (Unit: mm) (R: Indication of decimal point) |
| (3) | Shielding | Blank | Shielded |
| | | M | Unshielded |
| (4) | Output configuration | B | PNP open collector |
| | | C | NPN open collector |
| (5) | Operation mode | 1 | Normally open (NO) |
| | | 2 | Normally closed (NC) |
| | | 3 | Normally open, Normally closed (NO+NC) |
| (6) | IO-Link baud rate | Blank | IO-Link baud rate |
| | | D | COM2 (38.4 kbps) |
| | | T | COM3 (230.4 kbps) |
| (7) | Body size | Blank | Standard |
| | | L | Long Body |
| (8) | Size | 8 | M8 |
| | | 12 | M12 |
| | | 18 | M18 |
| | | 30 | M30 |
| (9) | Connection method | Blank | Pre-wired Models |
| | | M1 | M12 Connector Models |
| | | M3 | M8 (4-pin) Connector Models |
| | | M5 | M8 (3-pin) Connector Models |
| | | M1TJ | M12 Pre-wired Smartclick Connector Models (pigtail) |
| | | M1TJR | M12 Pre-wired Smartclick Connector Models Robot (bending-resistant) cable (robot pigtail) |
| (10) | Cable specifications * | Blank | Standard PVC cable |
| | | R | Robot (bending-resistant) cable |
| (11) | Cable length | Number M | Cable length |

* (10) is only shown in the model number of Pre-wired Models.

Note: The purpose of this model number legend is to provide understanding of the meaning of specifications from the model number. Models are not available for all combinations of code numbers.

Ordering Information

PREMIUM Model

E2E NEXT Series (Quadruple distance model)

DC 3-wire [Refer to *Dimensions* on page 50.]

Shielded *1

| Size (Sensing distance) | Connection method | Body size | Operation mode | Model | | |
|--|--|--------------------|----------------|-------------------------|------------------------|----------------|
| | | | | PNP | NPN | |
| M8 (4 mm) | Pre-wired (2 m) *2 | 38 mm *3 | NO | E2E-X4B1D8 2M | E2E-X4C18 2M | |
| | | | NC | E2E-X4B28 2M | E2E-X4C28 2M | |
| | | 48 mm | NO | E2E-X4B1DL8 2M | E2E-X4C1L8 2M | |
| | | | NC | E2E-X4B2L8 2M | E2E-X4C2L8 2M | |
| | M12 Pre-wired Smartclick Connector (0.3 m) | 38 mm *4 | NO | E2E-X4B1D8-M1TJ 0.3M | E2E-X4C18-M1TJ 0.3M | |
| | | | NC | E2E-X4B28-M1TJ 0.3M | E2E-X4C28-M1TJ 0.3M | |
| | | 48 mm | NO | E2E-X4B1DL8-M1TJ 0.3M | E2E-X4C1L8-M1TJ 0.3M | |
| | | | NC | E2E-X4B2L8-M1TJ 0.3M | E2E-X4C2L8-M1TJ 0.3M | |
| | M12 Connector | 43 mm | NO | E2E-X4B1D8-M1 | E2E-X4C18-M1 | |
| | | | NC | E2E-X4B28-M1 | E2E-X4C28-M1 | |
| | | 53 mm | NO | E2E-X4B1DL8-M1 | E2E-X4C1L8-M1 | |
| | | | NC | E2E-X4B2L8-M1 | E2E-X4C2L8-M1 | |
| | M8 Connector (4-pin) | 39 mm | NO | E2E-X4B1D8-M3 | E2E-X4C18-M3 | |
| | | | NC | E2E-X4B28-M3 | E2E-X4C28-M3 | |
| | | 49 mm | NO | E2E-X4B1DL8-M3 | E2E-X4C1L8-M3 | |
| | | | NC | E2E-X4B2L8-M3 | E2E-X4C2L8-M3 | |
| | M8 Connector (3-pin) | 39 mm | NO | E2E-X4B1D8-M5 | E2E-X4C18-M5 | |
| | | | NC | E2E-X4B28-M5 | E2E-X4C28-M5 | |
| | | 49 mm | NO | E2E-X4B1DL8-M5 | E2E-X4C1L8-M5 | |
| | | | NC | E2E-X4B2L8-M5 | E2E-X4C2L8-M5 | |
| | M12 (9 mm) | Pre-wired (2 m) *2 | 47 mm *3 | NO | E2E-X9B1D12 2M | E2E-X9C112 2M |
| | | | | NC | E2E-X9B212 2M | E2E-X9C212 2M |
| | | | 69 mm | NO | E2E-X9B1DL12 2M | E2E-X9C1L12 2M |
| | | | | NC | E2E-X9B2L12 2M | E2E-X9C2L12 2M |
| M12 Pre-wired Smartclick Connector (0.3 m) | | 47 mm *4 | NO | E2E-X9B1D12-M1TJ 0.3M | E2E-X9C112-M1TJ 0.3M | |
| | | | NC | E2E-X9B212-M1TJ 0.3M | E2E-X9C212-M1TJ 0.3M | |
| | | 69 mm | NO | E2E-X9B1DL12-M1TJ 0.3M | E2E-X9C1L12-M1TJ 0.3M | |
| | | | NC | E2E-X9B2L12-M1TJ 0.3M | E2E-X9C2L12-M1TJ 0.3M | |
| M12 Connector | | 48 mm | NO | E2E-X9B1D12-M1 | E2E-X9C112-M1 | |
| | | | NC | E2E-X9B212-M1 | E2E-X9C212-M1 | |
| | | 70 mm | NO | E2E-X9B1DL12-M1 | E2E-X9C1L12-M1 | |
| | | | NC | E2E-X9B2L12-M1 | E2E-X9C2L12-M1 | |
| M18 (14 mm) | Pre-wired (2 m) *2 | 55 mm *3 | NO | E2E-X14B1D18 2M | E2E-X14C118 2M | |
| | | | NC | E2E-X14B218 2M | E2E-X14C218 2M | |
| | | 77 mm | NO | E2E-X14B1DL18 2M | E2E-X14C1L18 2M | |
| | | | NC | E2E-X14B2L18 2M | E2E-X14C2L18 2M | |
| | M12 Pre-wired Smartclick Connector (0.3 m) | 55 mm *4 | NO | E2E-X14B1D18-M1TJ 0.3M | E2E-X14C118-M1TJ 0.3M | |
| | | | NC | E2E-X14B218-M1TJ 0.3M | E2E-X14C218-M1TJ 0.3M | |
| | | 77 mm | NO | E2E-X14B1DL18-M1TJ 0.3M | E2E-X14C1L18-M1TJ 0.3M | |
| | | | NC | E2E-X14B2L18-M1TJ 0.3M | E2E-X14C2L18-M1TJ 0.3M | |
| | M12 Connector | 53 mm | NO | E2E-X14B1D18-M1 | E2E-X14C118-M1 | |
| | | | NC | E2E-X14B218-M1 | E2E-X14C218-M1 | |
| | | 75 mm | NO | E2E-X14B1DL18-M1 | E2E-X14C1L18-M1 | |
| | | | NC | E2E-X14B2L18-M1 | E2E-X14C2L18-M1 | |

E2E/E2EQ NEXT Series

PREMIUM Model

| Size (Sensing distance) | Connection method | Body size | Operation mode | Model | |
|-------------------------|--|-----------|----------------|-------------------------|------------------------|
| | | | | PNP | NPN |
| M30 (23 mm) | Pre-wired (2 m) *2 | 60 mm *2 | NO | E2E-X23B1D30 2M | E2E-X23C130 2M |
| | | | NC | E2E-X23B230 2M | E2E-X23C230 2M |
| | | 82 mm | NO | E2E-X23B1DL30 2M | E2E-X23C1L30 2M |
| | | | NC | E2E-X23B2L30 2M | E2E-X23C2L30 2M |
| | M12 Pre-wired Smartclick Connector (0.3 m) | 60 mm *4 | NO | E2E-X23B1D30-M1TJ 0.3M | E2E-X23C130-M1TJ 0.3M |
| | | | NC | E2E-X23B230-M1TJ 0.3M | E2E-X23C230-M1TJ 0.3M |
| | | 82 mm | NO | E2E-X23B1DL30-M1TJ 0.3M | E2E-X23C1L30-M1TJ 0.3M |
| | | | NC | E2E-X23B2L30-M1TJ 0.3M | E2E-X23C2L30-M1TJ 0.3M |
| | M12 Connector | 58 mm | NO | E2E-X23B1D30-M1 | E2E-X23C130-M1 |
| | | | NC | E2E-X23B230-M1 | E2E-X23C230-M1 |
| | | 80 mm | NO | E2E-X23B1DL30-M1 | E2E-X23C1L30-M1 |
| | | | NC | E2E-X23B2L30-M1 | E2E-X23C2L30-M1 |

*1. When embedding the Proximity Sensor in metal, refer to *Influence of Surrounding Metal* on page 48.

*2. Models with 5-m cable length are also available with "5M" suffix. (Example: E2E-X9B1D12 5M)

*3. Models with 2-m and 5-m robot (bending-resistant) cables are also available with "-R" in the model number. (Example: E2E-X9B1D12-R 2M/ E2E-X9B1D12-R 5M)

*4. Models with M12 Smartclick connector model robot (bending-resistant) cables are also available with "R" in the model number. (Example: E2E-X9B1D12-M1TJR 0.3M)

Note: 1. Models in are equipped with IO-Link (COM2). For IO-Link (COM3), select a model number with the format of "E2E-X□□□T□" (Example: E2E-X9B1T12 2M).

Operation mode NO can be changed to NC via IO-Link communications.

2. IO-Link is not supported for NC-type PNP outputs or all types of NPN outputs.

PREMIUM Model

E2E NEXT Series (Quadruple distance model)

DC 3-wire [Refer to Dimensions on page 50.]

Unshielded

| Size (Sensing distance) | Connection method | Body size | Operation mode | Model | | |
|--|--|--------------------|----------------|--------------------------|-------------------------|------------------|
| | | | | PNP | NPN | |
| M8 (8 mm) | Pre-wired (2 m) *1 | 38 mm *2 | NO | E2E-X8MB1D8 2M | E2E-X8MC18 2M | |
| | | | NC | E2E-X8MB28 2M | E2E-X8MC28 2M | |
| | | 48 mm | NO | E2E-X8MB1DL8 2M | E2E-X8MC1L8 2M | |
| | | | NC | E2E-X8MB2L8 2M | E2E-X8MC2L8 2M | |
| | M12 Pre-wired Smartclick Connector (0.3 m) | 38 mm *3 | NO | E2E-X8MB1D8-M1TJ 0.3M | E2E-X8MC18-M1TJ 0.3M | |
| | | | NC | E2E-X8MB28-M1TJ 0.3M | E2E-X8MC28-M1TJ 0.3M | |
| | | 48 mm | NO | E2E-X8MB1DL8-M1TJ 0.3M | E2E-X8MC1L8-M1TJ 0.3M | |
| | | | NC | E2E-X8MB2L8-M1TJ 0.3M | E2E-X8MC2L8-M1TJ 0.3M | |
| | M12 Connector | 43 mm | NO | E2E-X8MB1D8-M1 | E2E-X8MC18-M1 | |
| | | | NC | E2E-X8MB28-M1 | E2E-X8MC28-M1 | |
| | | 53 mm | NO | E2E-X8MB1DL8-M1 | E2E-X8MC1L8-M1 | |
| | | | NC | E2E-X8MB2L8-M1 | E2E-X8MC2L8-M1 | |
| | M8 Connector (4-pin) | 39 mm | NO | E2E-X8MB1D8-M3 | E2E-X8MC18-M3 | |
| | | | NC | E2E-X8MB28-M3 | E2E-X8MC28-M3 | |
| | | 49 mm | NO | E2E-X8MB1DL8-M3 | E2E-X8MC1L8-M3 | |
| | | | NC | E2E-X8MB2L8-M3 | E2E-X8MC2L8-M3 | |
| | M8 Connector (3-pin) | 39 mm | NO | E2E-X8MB1D8-M5 | E2E-X8MC18-M5 | |
| | | | NC | E2E-X8MB28-M5 | E2E-X8MC28-M5 | |
| | | 49 mm | NO | E2E-X8MB1DL8-M5 | E2E-X8MC1L8-M5 | |
| | | | NC | E2E-X8MB2L8-M5 | E2E-X8MC2L8-M5 | |
| | M12 (16 mm) | Pre-wired (2 m) *1 | 47 mm *2 | NO | E2E-X16MB1D12 2M | E2E-X16MC112 2M |
| | | | | NC | E2E-X16MB212 2M | E2E-X16MC212 2M |
| | | | 69 mm | NO | E2E-X16MB1DL12 2M | E2E-X16MC1L12 2M |
| | | | | NC | E2E-X16MB2L12 2M | E2E-X16MC2L12 2M |
| M12 Pre-wired Smartclick Connector (0.3 m) | | 47 mm *3 | NO | E2E-X16MB1D12-M1TJ 0.3M | E2E-X16MC112-M1TJ 0.3M | |
| | | | NC | E2E-X16MB212-M1TJ 0.3M | E2E-X16MC212-M1TJ 0.3M | |
| | | 69 mm | NO | E2E-X16MB1DL12-M1TJ 0.3M | E2E-X16MC1L12-M1TJ 0.3M | |
| | | | NC | E2E-X16MB2L12-M1TJ 0.3M | E2E-X16MC2L12-M1TJ 0.3M | |
| M12 Connector | | 48 mm | NO | E2E-X16MB1D12-M1 | E2E-X16MC112-M1 | |
| | | | NC | E2E-X16MB212-M1 | E2E-X16MC212-M1 | |
| | | 70 mm | NO | E2E-X16MB1DL12-M1 | E2E-X16MC1L12-M1 | |
| | | | NC | E2E-X16MB2L12-M1 | E2E-X16MC2L12-M1 | |
| M18 (30 mm) | Pre-wired (2 m) *1 | 77 mm *2 | NO | E2E-X30MB1DL18 2M | E2E-X30MC1L18 2M | |
| | | | NC | E2E-X30MB2L18 2M | E2E-X30MC2L18 2M | |
| | M12 Pre-wired Smartclick Connector (0.3 m) | 77 mm *3 | NO | E2E-X30MB1DL18-M1TJ 0.3M | E2E-X30MC1L18-M1TJ 0.3M | |
| | | | NC | E2E-X30MB2L18-M1TJ 0.3M | E2E-X30MC2L18-M1TJ 0.3M | |
| | M12 Connector | 75 mm | NO | E2E-X30MB1DL18-M1 | E2E-X30MC1L18-M1 | |
| | | | NC | E2E-X30MB2L18-M1 | E2E-X30MC2L18-M1 | |
| M30 (50 mm) | Pre-wired (2 m) *1 | 97 mm *2 | NO | E2E-X50MB1DL30 2M | E2E-X50MC1L30 2M | |
| | | | NC | E2E-X50MB2L30 2M | E2E-X50MC2L30 2M | |
| | M12 Pre-wired Smartclick Connector (0.3 m) | 97 mm *3 | NO | E2E-X50MB1DL30-M1TJ 0.3M | E2E-X50MC1L30-M1TJ 0.3M | |
| | | | NC | E2E-X50MB2L30-M1TJ 0.3M | E2E-X50MC2L30-M1TJ 0.3M | |
| | M12 Connector | 95 mm | NO | E2E-X50MB1DL30-M1 | E2E-X50MC1L30-M1 | |
| | | | NC | E2E-X50MB2L30-M1 | E2E-X50MC2L30-M1 | |

*1. Models with 5-m cable length are also available (Example: E2E-X16MB1D12 5M)

*2. Models with 2-m and 5-m robot (bending-resistant) cables are also available with "-R" in the model number. (Example: E2E-X16MB1D12-R 2M/E2E-X16MB1D12-R 5M)

*3. Models with M12 Smartclick connector model robot (bending-resistant) cables are also available with "R" in the model number. (Example: E2E-X16MB1D12-M1TJR 0.3M)

Note: 1. Models in are equipped with IO-Link (COM2). For IO-Link (COM3), select a model number with the format of "E2E-X□□□□□" (Example: E2E-X16MB1T12 2M).

Operation mode NO can be changed to NC via IO-Link communications.

2. IO-Link is not supported for NC-type PNP outputs or all types of NPN outputs.

E2E/E2EQ NEXT Series

PREMIUM Model

E2E NEXT Series (Triple distance model)

DC 3-wire [Refer to *Dimensions* on page 50.]

Shielded *1

| Size (Sensing distance) | Connection method | Body size | Operation mode | Model | | |
|--|--|--------------------|----------------|------------------------|-----------------------|----------------------|
| | | | | PNP | NPN | |
| M8 (3 mm) | Pre-wired (2 m) *2 | 38 mm *3 | NO | E2E-X3B1D8 2M | E2E-X3C18 2M | |
| | | | NC | E2E-X3B28 2M | E2E-X3C28 2M | |
| | | 48 mm | NO | E2E-X3B1DL8 2M | E2E-X3C1L8 2M | |
| | | | NC | E2E-X3B2L8 2M | E2E-X3C2L8 2M | |
| | M12 Pre-wired Smartclick Connector (0.3 m) | 38 mm *4 | NO | E2E-X3B1D8-M1TJ 0.3M | E2E-X3C18-M1TJ 0.3M | |
| | | | NC | E2E-X3B28-M1TJ 0.3M | E2E-X3C28-M1TJ 0.3M | |
| | | 48 mm | NO | E2E-X3B1DL8-M1TJ 0.3M | E2E-X3C1L8-M1TJ 0.3M | |
| | | | NC | E2E-X3B2L8-M1TJ 0.3M | E2E-X3C2L8-M1TJ 0.3M | |
| | M12 Connector | 43 mm | NO | E2E-X3B1D8-M1 | E2E-X3C18-M1 | |
| | | | NC | E2E-X3B28-M1 | E2E-X3C28-M1 | |
| | | 53 mm | NO | E2E-X3B1DL8-M1 | E2E-X3C1L8-M1 | |
| | | | NC | E2E-X3B2L8-M1 | E2E-X3C2L8-M1 | |
| | M8 Connector (4-pin) | 39 mm | NO | E2E-X3B1D8-M3 | E2E-X3C18-M3 | |
| | | | NC | E2E-X3B28-M3 | E2E-X3C28-M3 | |
| | | 49 mm | NO | E2E-X3B1DL8-M3 | E2E-X3C1L8-M3 | |
| | | | NC | E2E-X3B2L8-M3 | E2E-X3C2L8-M3 | |
| | M8 Connector (3-pin) | 39 mm | NO | E2E-X3B1D8-M5 | E2E-X3C18-M5 | |
| | | | NC | E2E-X3B28-M5 | E2E-X3C28-M5 | |
| | | 49 mm | NO | E2E-X3B1DL8-M5 | E2E-X3C1L8-M5 | |
| | | | NC | E2E-X3B2L8-M5 | E2E-X3C2L8-M5 | |
| | M12 (6 mm) | Pre-wired (2 m) *2 | 47 mm *3 | NO | E2E-X6B1D12 2M | E2E-X6C112 2M |
| | | | | NC | E2E-X6B212 2M | E2E-X6C212 2M |
| | | | | NO+NC | E2E-X6B3D12 2M | E2E-X6C312 2M |
| | | | 69 mm | NO | E2E-X6B1DL12 2M | E2E-X6C1L12 2M |
| NC | | | | E2E-X6B2L12 2M | E2E-X6C2L12 2M | |
| NO+NC | | | | E2E-X6B3DL12 2M | E2E-X6C3L12 2M | |
| M12 Pre-wired Smartclick Connector (0.3 m) | | | 47 mm *4 | NO | E2E-X6B1D12-M1TJ 0.3M | E2E-X6C112-M1TJ 0.3M |
| | | | | NC | E2E-X6B212-M1TJ 0.3M | E2E-X6C212-M1TJ 0.3M |
| | | NO+NC | | E2E-X6B3D12-M1TJ 0.3M | E2E-X6C312-M1TJ 0.3M | |
| | | 69 mm | NO | E2E-X6B1DL12-M1TJ 0.3M | E2E-X6C1L12-M1TJ 0.3M | |
| | | | NC | E2E-X6B2L12-M1TJ 0.3M | E2E-X6C2L12-M1TJ 0.3M | |
| | | | NO+NC | E2E-X6B3DL12-M1TJ 0.3M | E2E-X6C3L12-M1TJ 0.3M | |
| M12 Connector | | 48 mm | NO | E2E-X6B1D12-M1 | E2E-X6C112-M1 | |
| | | | NC | E2E-X6B212-M1 | E2E-X6C212-M1 | |
| | | | NO+NC | E2E-X6B3D12-M1 | E2E-X6C312-M1 | |
| | | 70 mm | NO | E2E-X6B1DL12-M1 | E2E-X6C1L12-M1 | |
| | | | NC | E2E-X6B2L12-M1 | E2E-X6C2L12-M1 | |
| | | | NO+NC | E2E-X6B3DL12-M1 | E2E-X6C3L12-M1 | |

PREMIUM Model

| Size (Sensing distance) | Connection method | Body size | Operation mode | Model | |
|-------------------------|--|-----------|----------------|-------------------------|------------------------|
| | | | | PNP | NPN |
| M18 (12 mm) | Pre-wired (2 m) *2 | 55 mm *3 | NO | E2E-X12B1D18 2M | E2E-X12C118 2M |
| | | | NC | E2E-X12B218 2M | E2E-X12C218 2M |
| | | | NO+NC | E2E-X12B3D18 2M | E2E-X12C318 2M |
| | | 77 mm | NO | E2E-X12B1DL18 2M | E2E-X12C1L18 2M |
| | | | NC | E2E-X12B2L18 2M | E2E-X12C2L18 2M |
| | | | NO+NC | E2E-X12B3DL18 2M | E2E-X12C3L18 2M |
| | M12 Pre-wired Smartclick Connector (0.3 m) | 55 mm *4 | NO | E2E-X12B1D18-M1TJ 0.3M | E2E-X12C118-M1TJ 0.3M |
| | | | NC | E2E-X12B218-M1TJ 0.3M | E2E-X12C218-M1TJ 0.3M |
| | | | NO+NC | E2E-X12B3D18-M1TJ 0.3M | E2E-X12C318-M1TJ 0.3M |
| | | 77 mm | NO | E2E-X12B1DL18-M1TJ 0.3M | E2E-X12C1L18-M1TJ 0.3M |
| | | | NC | E2E-X12B2L18-M1TJ 0.3M | E2E-X12C2L18-M1TJ 0.3M |
| | | | NO+NC | E2E-X12B3DL18-M1TJ 0.3M | E2E-X12C3L18-M1TJ 0.3M |
| | M12 Connector | 53 mm | NO | E2E-X12B1D18-M1 | E2E-X12C118-M1 |
| | | | NC | E2E-X12B218-M1 | E2E-X12C218-M1 |
| | | | NO+NC | E2E-X12B3D18-M1 | E2E-X12C318-M1 |
| | | 75 mm | NO | E2E-X12B1DL18-M1 | E2E-X12C1L18-M1 |
| | | | NC | E2E-X12B2L18-M1 | E2E-X12C2L18-M1 |
| | | | NO+NC | E2E-X12B3DL18-M1 | E2E-X12C3L18-M1 |
| M30 (22 mm) | Pre-wired (2 m) *2 | 60 mm *3 | NO | E2E-X22B1D30 2M | E2E-X22C130 2M |
| | | | NC | E2E-X22B230 2M | E2E-X22C230 2M |
| | | | NO+NC | E2E-X22B3D30 2M | E2E-X22C330 2M |
| | | 82 mm | NO | E2E-X22B1DL30 2M | E2E-X22C1L30 2M |
| | | | NC | E2E-X22B2L30 2M | E2E-X22C2L30 2M |
| | | | NO+NC | E2E-X22B3DL30 2M | E2E-X22C3L30 2M |
| | M12 Pre-wired Smartclick Connector (0.3 m) | 60 mm *4 | NO | E2E-X22B1D30-M1TJ 0.3M | E2E-X22C130-M1TJ 0.3M |
| | | | NC | E2E-X22B230-M1TJ 0.3M | E2E-X22C230-M1TJ 0.3M |
| | | | NO+NC | E2E-X22B3D30-M1TJ 0.3M | E2E-X22C330-M1TJ 0.3M |
| | | 82 mm | NO | E2E-X22B1DL30-M1TJ 0.3M | E2E-X22C1L30-M1TJ 0.3M |
| | | | NC | E2E-X22B2L30-M1TJ 0.3M | E2E-X22C2L30-M1TJ 0.3M |
| | | | NO+NC | E2E-X22B3DL30-M1TJ 0.3M | E2E-X22C3L30-M1TJ 0.3M |
| | M12 Connector | 58 mm | NO | E2E-X22B1D30-M1 | E2E-X22C130-M1 |
| | | | NC | E2E-X22B230-M1 | E2E-X22C230-M1 |
| | | | NO+NC | E2E-X22B3D30-M1 | E2E-X22C330-M1 |
| | | 80 mm | NO | E2E-X22B1DL30-M1 | E2E-X22C1L30-M1 |
| | | | NC | E2E-X22B2L30-M1 | E2E-X22C2L30-M1 |
| | | | NO+NC | E2E-X22B3DL30-M1 | E2E-X22C3L30-M1 |

*1. When embedding the Proximity Sensor in metal, refer to *Influence of Surrounding Metal* on page 48.

*2. Models with 5-m cable length are also available (Example: E2E-X6B1D12 5M)

*3. Models with 2-m and 5-m robot (bending-resistant) cables are also available with "-R" in the model number. (Example: E2E-X6B1D12-R 2M/ E2E-X6B1D12-R 5M)

*4. Models with M12 Smartclick connector model robot (bending-resistant) cables are also available with "R" in the model number. (Example: E2E-X6B1D12-M1TJR 0.3M)

Note: 1. Models in are equipped with IO-Link (COM2). For IO-Link (COM3), select a model number with the format of "E2E-X□□□□□" (Example: E2E-X6B1T12 2M).

Operation mode NO can be changed to NC via IO-Link communications.

2. IO-Link is not supported for NC-type PNP outputs or all types of NPN outputs.

E2E/E2EQ NEXT Series

PREMIUM Model

E2E NEXT Series (Triple distance model)

DC 3-wire [Refer to *Dimensions* on page 50.]

Unshielded

| Size (Sensing distance) | Connection method | Body size | Operation mode | Model | | |
|--|--|--|----------------|--------------------------|--------------------------|-------------------------|
| | | | | PNP | NPN | |
| M8 (6 mm) | Pre-wired (2 m) *1 | 38 mm *2 | NO | E2E-X6MB1D8 2M | E2E-X6MC18 2M | |
| | | | NC | E2E-X6MB28 2M | E2E-X6MC28 2M | |
| | | 48 mm | NO | E2E-X6MB1DL8 2M | E2E-X6MC1L8 2M | |
| | | | NC | E2E-X6MB2L8 2M | E2E-X6MC2L8 2M | |
| | M12 Pre-wired Smartclick Connector (0.3 m) | 38 mm *3 | NO | E2E-X6MB1D8-M1TJ 0.3M | E2E-X6MC18-M1TJ 0.3M | |
| | | | NC | E2E-X6MB28-M1TJ 0.3M | E2E-X6MC28-M1TJ 0.3M | |
| | | 48 mm | NO | E2E-X6MB1DL8-M1TJ 0.3M | E2E-X6MC1L8-M1TJ 0.3M | |
| | | | NC | E2E-X6MB2L8-M1TJ 0.3M | E2E-X6MC2L8-M1TJ 0.3M | |
| | | M12 Connector | 43 mm | NO | E2E-X6MB1D8-M1 | E2E-X6MC18-M1 |
| | | | | NC | E2E-X6MB28-M1 | E2E-X6MC28-M1 |
| | 53 mm | | NO | E2E-X6MB1DL8-M1 | E2E-X6MC1L8-M1 | |
| | | NC | E2E-X6MB2L8-M1 | E2E-X6MC2L8-M1 | | |
| | M8 Connector (4-pin) | 39 mm | NO | E2E-X6MB1D8-M3 | E2E-X6MC18-M3 | |
| | | | NC | E2E-X6MB28-M3 | E2E-X6MC28-M3 | |
| | | 49 mm | NO | E2E-X6MB1DL8-M3 | E2E-X6MC1L8-M3 | |
| | | | NC | E2E-X6MB2L8-M3 | E2E-X6MC2L8-M3 | |
| | M8 Connector (3-pin) | 39 mm | NO | E2E-X6MB1D8-M5 | E2E-X6MC18-M5 | |
| | | | NC | E2E-X6MB28-M5 | E2E-X6MC28-M5 | |
| | | 49 mm | NO | E2E-X6MB1DL8-M5 | E2E-X6MC1L8-M5 | |
| | | | NC | E2E-X6MB2L8-M5 | E2E-X6MC2L8-M5 | |
| | M12 (10 mm) | Pre-wired (2 m) *1 | 47 mm *2 | NO | E2E-X10MB1D12 2M | E2E-X10MC112 2M |
| | | | | NC | E2E-X10MB212 2M | E2E-X10MC212 2M |
| | | | | NO+NC | E2E-X10MB3D12 2M | E2E-X10MC312 2M |
| | | | 69 mm | NO | E2E-X10MB1DL12 2M | E2E-X10MC1L12 2M |
| NC | | | | E2E-X10MB2L12 2M | E2E-X10MC2L12 2M | |
| NO+NC | | | | E2E-X10MB3DL12 2M | E2E-X10MC3L12 2M | |
| M12 Pre-wired Smartclick Connector (0.3 m) | | | 47 mm *3 | NO | E2E-X10MB1D12-M1TJ 0.3M | E2E-X10MC112-M1TJ 0.3M |
| | | | | NC | E2E-X10MB212-M1TJ 0.3M | E2E-X10MC212-M1TJ 0.3M |
| | | | | NO+NC | E2E-X10MB3D12-M1TJ 0.3M | E2E-X10MC312-M1TJ 0.3M |
| | | 69 mm | NO | E2E-X10MB1DL12-M1TJ 0.3M | E2E-X10MC1L12-M1TJ 0.3M | |
| | | | NC | E2E-X10MB2L12-M1TJ 0.3M | E2E-X10MC2L12-M1TJ 0.3M | |
| | | | NO+NC | E2E-X10MB3DL12-M1TJ 0.3M | E2E-X10MC3L12-M1TJ 0.3M | |
| M12 Connector | | 48 mm | NO | E2E-X10MB1D12-M1 | E2E-X10MC112-M1 | |
| | | | NC | E2E-X10MB212-M1 | E2E-X10MC212-M1 | |
| | | | NO+NC | E2E-X10MB3D12-M1 | E2E-X10MC312-M1 | |
| | | 70 mm | NO | E2E-X10MB1DL12-M1 | E2E-X10MC1L12-M1 | |
| | | | NC | E2E-X10MB2L12-M1 | E2E-X10MC2L12-M1 | |
| | | | NO+NC | E2E-X10MB3DL12-M1 | E2E-X10MC3L12-M1 | |
| M18 (20 mm) | | Pre-wired (2 m) *1 | 77 mm *2 | NO | E2E-X20MB1DL18 2M | E2E-X20MC1L18 2M |
| | | | | NC | E2E-X20MB2L18 2M | E2E-X20MC2L18 2M |
| | | | | NO+NC | E2E-X20MB3DL18 2M | E2E-X20MC3L18 2M |
| | | M12 Pre-wired Smartclick Connector (0.3 m) | 77 mm *3 | NO | E2E-X20MB1DL18-M1TJ 0.3M | E2E-X20MC1L18-M1TJ 0.3M |
| | | | | NC | E2E-X20MB2L18-M1TJ 0.3M | E2E-X20MC2L18-M1TJ 0.3M |
| | | | | NO+NC | E2E-X20MB3DL18-M1TJ 0.3M | E2E-X20MC3L18-M1TJ 0.3M |
| | M12 Connector | 75 mm | NO | E2E-X20MB1DL18-M1 | E2E-X20MC1L18-M1 | |
| | | | NC | E2E-X20MB2L18-M1 | E2E-X20MC2L18-M1 | |
| | | | NO+NC | E2E-X20MB3DL18-M1 | E2E-X20MC3L18-M1 | |

PREMIUM Model

| Size (Sensing distance) | Connection method | Body size | Operation mode | Model | |
|-------------------------|--|-----------|----------------|--------------------------|-------------------------|
| | | | | PNP | NPN |
| M30 (40 mm) | Pre-wired (2 m) *1 | 82 mm *2 | NO | E2E-X40MB1DL30 2M | E2E-X40MC1L30 2M |
| | | | NC | E2E-X40MB2L30 2M | E2E-X40MC2L30 2M |
| | | | NO+NC | E2E-X40MB3DL30 2M | E2E-X40MC3L30 2M |
| | M12 Pre-wired Smartclick Connector (0.3 m) | 82 mm *3 | NO | E2E-X40MB1DL30-M1TJ 0.3M | E2E-X40MC1L30-M1TJ 0.3M |
| | | | NC | E2E-X40MB2L30-M1TJ 0.3M | E2E-X40MC2L30-M1TJ 0.3M |
| | | | NO+NC | E2E-X40MB3DL30-M1TJ 0.3M | E2E-X40MC3L30-M1TJ 0.3M |
| | M12 Connector | 80 mm | NO | E2E-X40MB1DL30-M1 | E2E-X40MC1L30-M1 |
| | | | NC | E2E-X40MB2L30-M1 | E2E-X40MC2L30-M1 |
| | | | NO+NC | E2E-X40MB3DL30-M1 | E2E-X40MC3L30-M1 |

*1. Models with 5-m cable length are also available (Example: E2E-X10MB1D12 5M)

*2. Models with 2-m and 5-m robot (bending-resistant) cables are also available with "-R" in the model number. (Example: E2E-X10MB1D12-R 2M/E2E-X10MB1D12-R 5M)

*3. Models with M12 Smartclick connector model robot (bending-resistant) cables are also available with "R" in the model number. (Example: E2E-X10MB1D12-M1TJR 0.3M)

Note: 1. Models in are equipped with IO-Link (COM2). For IO-Link (COM3), select a model number with the format of "E2E-X□□□□T□" (Example: E2E-X10MB1T12 2M).

Operation mode NO can be changed to NC via IO-Link communications.

2. IO-Link is not supported for NC-type PNP outputs or all types of NPN outputs.

E2E/E2EQ NEXT Series

PREMIUM Model

E2EQ NEXT Series (Spatter-resistant Triple distance model)

DC 3-wire [Refer to *Dimensions* on page 50.]

Shielded *1

| Size (Sensing distance) | Connection method | Body size | Operation mode | Model | |
|-------------------------|--|-----------|----------------|-------------------------|------------------------|
| | | | | PNP | NPN |
| M8 (3 mm) | Pre-wired (2 m) *2 | 38 mm | NO | E2EQ-X3B1D8 2M | E2EQ-X3C18 2M |
| | | | NC | E2EQ-X3B28 2M | E2EQ-X3C28 2M |
| | M12 Pre-wired Smartclick Connector (0.3 m) | 38 mm | NO | E2EQ-X3B1D8-M1TJ 0.3M | E2EQ-X3C18-M1TJ 0.3M |
| | | | NC | E2EQ-X3B28-M1TJ 0.3M | E2EQ-X3C28-M1TJ 0.3M |
| | M12 Connector | 43 mm | NO | E2EQ-X3B1D8-M1 | E2EQ-X3C18-M1 |
| | | | NC | E2EQ-X3B28-M1 | E2EQ-X3C28-M1 |
| M12 (6 mm) | Pre-wired (2 m) *2 | 47 mm | NO | E2EQ-X6B1D12 2M | E2EQ-X6C112 2M |
| | | | NC | E2EQ-X6B212 2M | E2EQ-X6C212 2M |
| | | | NO+NC | E2EQ-X6B3D12 2M | E2EQ-X6C312 2M |
| | M12 Pre-wired Smartclick Connector (0.3 m) | 47 mm | NO | E2EQ-X6B1D12-M1TJ 0.3M | E2EQ-X6C112-M1TJ 0.3M |
| | | | NC | E2EQ-X6B212-M1TJ 0.3M | E2EQ-X6C212-M1TJ 0.3M |
| | | | NO+NC | E2EQ-X6B3D12-M1TJ 0.3M | E2EQ-X6C312-M1TJ 0.3M |
| | M12 Connector | 48 mm | NO | E2EQ-X6B1D12-M1 | E2EQ-X6C112-M1 |
| | | | NC | E2EQ-X6B212-M1 | E2EQ-X6C212-M1 |
| | | | NO+NC | E2EQ-X6B3D12-M1 | E2EQ-X6C312-M1 |
| M18 (12 mm) | Pre-wired (2 m) *2 | 55 mm | NO | E2EQ-X12B1D18 2M | E2EQ-X12C118 2M |
| | | | NC | E2EQ-X12B218 2M | E2EQ-X12C218 2M |
| | | | NO+NC | E2EQ-X12B3D18 2M | E2EQ-X12C318 2M |
| | M12 Pre-wired Smartclick Connector (0.3 m) | 55 mm | NO | E2EQ-X12B1D18-M1TJ 0.3M | E2EQ-X12C118-M1TJ 0.3M |
| | | | NC | E2EQ-X12B218-M1TJ 0.3M | E2EQ-X12C218-M1TJ 0.3M |
| | | | NO+NC | E2EQ-X12B3D18-M1TJ 0.3M | E2EQ-X12C318-M1TJ 0.3M |
| | M12 Connector | 53 mm | NO | E2EQ-X12B1D18-M1 | E2EQ-X12C118-M1 |
| | | | NC | E2EQ-X12B218-M1 | E2EQ-X12C218-M1 |
| | | | NO+NC | E2EQ-X12B3D18-M1 | E2EQ-X12C318-M1 |
| M30 (22 mm) | Pre-wired (2 m) *2 | 60 mm | NO | E2EQ-X22B1D30 2M | E2EQ-X22C130 2M |
| | | | NC | E2EQ-X22B230 2M | E2EQ-X22C230 2M |
| | | | NO+NC | E2EQ-X22B3D30 2M | E2EQ-X22C330 2M |
| | M12 Pre-wired Smartclick Connector (0.3 m) | 60 mm | NO | E2EQ-X22B1D30-M1TJ 0.3M | E2EQ-X22C130-M1TJ 0.3M |
| | | | NC | E2EQ-X22B230-M1TJ 0.3M | E2EQ-X22C230-M1TJ 0.3M |
| | | | NO+NC | E2EQ-X22B3D30-M1TJ 0.3M | E2EQ-X22C330-M1TJ 0.3M |
| | M12 Connector | 58 mm | NO | E2EQ-X22B1D30-M1 | E2EQ-X22C130-M1 |
| | | | NC | E2EQ-X22B230-M1 | E2EQ-X22C230-M1 |
| | | | NO+NC | E2EQ-X22B3D30-M1 | E2EQ-X22C330-M1 |

*1. When embedding the Proximity Sensor in metal, refer to *Influence of Surrounding Metal* on page 48.

*2. Models with 5-m cable length are also available (Example: E2EQ-X6B1D12 5M)

Note: 1. Models in are equipped with IO-Link (COM2). For IO-Link (COM3), select a model number with the format of "E2E-X□□□T□" (Example: E2EQ-X6B1T12 2M).

Operation mode NO can be changed to NC via IO-Link communications.

2. IO-Link is not supported for NC-type PNP outputs or all types of NPN outputs.

BASIC Model

E2E NEXT Series (Double distance model)

DC 3-wire [Refer to *Dimensions* on page 51.]

Shielded

| Size (Sensing distance) | Connection method | Body size | Operation mode | Model | | |
|--|--|--------------------|----------------|------------------------|-----------------------|----------------|
| | | | | PNP | NPN | |
| M8 (2 mm) | Pre-wired (2 m) *1 | 38 mm *2 | NO | E2E-X2B1D8 2M | E2E-X2C18 2M | |
| | | | NC | E2E-X2B28 2M | E2E-X2C28 2M | |
| | | 48 mm | NO | E2E-X2B1DL8 2M | E2E-X2C1L8 2M | |
| | | | NC | E2E-X2B2L8 2M | E2E-X2C2L8 2M | |
| | M12 Pre-wired Smartclick Connector (0.3 m) | 38 mm *3 | NO | E2E-X2B1D8-M1TJ 0.3M | E2E-X2C18-M1TJ 0.3M | |
| | | | NC | E2E-X2B28-M1TJ 0.3M | E2E-X2C28-M1TJ 0.3M | |
| | | 48 mm | NO | E2E-X2B1DL8-M1TJ 0.3M | E2E-X2C1L8-M1TJ 0.3M | |
| | | | NC | E2E-X2B2L8-M1TJ 0.3M | E2E-X2C2L8-M1TJ 0.3M | |
| | M12 Connector | 43 mm | NO | E2E-X2B1D8-M1 | E2E-X2C18-M1 | |
| | | | NC | E2E-X2B28-M1 | E2E-X2C28-M1 | |
| | | 53 mm | NO | E2E-X2B1DL8-M1 | E2E-X2C1L8-M1 | |
| | | | NC | E2E-X2B2L8-M1 | E2E-X2C2L8-M1 | |
| | M8 Connector (4-pin) | 39 mm | NO | E2E-X2B1D8-M3 | E2E-X2C18-M3 | |
| | | | NC | E2E-X2B28-M3 | E2E-X2C28-M3 | |
| | | 49 mm | NO | E2E-X2B1DL8-M3 | E2E-X2C1L8-M3 | |
| | | | NC | E2E-X2B2L8-M3 | E2E-X2C2L8-M3 | |
| | M8 Connector (3-pin) | 39 mm | NO | E2E-X2B1D8-M5 | E2E-X2C18-M5 | |
| | | | NC | E2E-X2B28-M5 | E2E-X2C28-M5 | |
| | | 49 mm | NO | E2E-X2B1DL8-M5 | E2E-X2C1L8-M5 | |
| | | | NC | E2E-X2B2L8-M5 | E2E-X2C2L8-M5 | |
| | M12 (4 mm) | Pre-wired (2 m) *1 | 47 mm *2 | NO | E2E-X4B1D12 2M | E2E-X4C112 2M |
| | | | | NC | E2E-X4B212 2M | E2E-X4C212 2M |
| | | | | NO+NC | E2E-X4B3D12 2M | E2E-X4C312 2M |
| | | | 69 mm | NO | E2E-X4B1DL12 2M | E2E-X4C1L12 2M |
| NC | | | | E2E-X4B2L12 2M | E2E-X4C2L12 2M | |
| NO+NC | | | | E2E-X4B3DL12 2M | E2E-X4C3L12 2M | |
| M12 Pre-wired Smartclick Connector (0.3 m) | | 47 mm *3 | NO | E2E-X4B1D12-M1TJ 0.3M | E2E-X4C112-M1TJ 0.3M | |
| | | | NC | E2E-X4B212-M1TJ 0.3M | E2E-X4C212-M1TJ 0.3M | |
| | | | NO+NC | E2E-X4B3D12-M1TJ 0.3M | E2E-X4C312-M1TJ 0.3M | |
| | | 69 mm | NO | E2E-X4B1DL12-M1TJ 0.3M | E2E-X4C1L12-M1TJ 0.3M | |
| | | | NC | E2E-X4B2L12-M1TJ 0.3M | E2E-X4C2L12-M1TJ 0.3M | |
| | | | NO+NC | E2E-X4B3DL12-M1TJ 0.3M | E2E-X4C3L12-M1TJ 0.3M | |
| M12 Connector | | 48 mm | NO | E2E-X4B1D12-M1 | E2E-X4C112-M1 | |
| | | | NC | E2E-X4B212-M1 | E2E-X4C212-M1 | |
| | | | NO+NC | E2E-X4B3D12-M1 | E2E-X4C312-M1 | |
| | | 70 mm | NO | E2E-X4B1DL12-M1 | E2E-X4C1L12-M1 | |
| | | | NC | E2E-X4B2L12-M1 | E2E-X4C2L12-M1 | |
| | | | NO+NC | E2E-X4B3DL12-M1 | E2E-X4C3L12-M1 | |

E2E/E2EQ NEXT Series

BASIC Model

| Size (Sensing distance) | Connection method | Body size | Operation mode | Model | |
|-------------------------|--|-----------|----------------|-------------------------|------------------------|
| | | | | PNP | NPN |
| M18 (8 mm) | Pre-wired (2 m) *1 | 55 mm *2 | NO | E2E-X8B1D18 2M | E2E-X8C118 2M |
| | | | NC | E2E-X8B218 2M | E2E-X8C218 2M |
| | | | NO+NC | E2E-X8B3D18 2M | E2E-X8C318 2M |
| | | 77 mm | NO | E2E-X8B1DL18 2M | E2E-X8C1L18 2M |
| | | | NC | E2E-X8B2L18 2M | E2E-X8C2L18 2M |
| | | | NO+NC | E2E-X8B3DL18 2M | E2E-X8C3L18 2M |
| | M12 Pre-wired Smartclick Connector (0.3 m) | 55 mm *3 | NO | E2E-X8B1D18-M1TJ 0.3M | E2E-X8C118-M1TJ 0.3M |
| | | | NC | E2E-X8B218-M1TJ 0.3M | E2E-X8C218-M1TJ 0.3M |
| | | | NO+NC | E2E-X8B3D18-M1TJ 0.3M | E2E-X8C318-M1TJ 0.3M |
| | | 77 mm | NO | E2E-X8B1DL18-M1TJ 0.3M | E2E-X8C1L18-M1TJ 0.3M |
| | | | NC | E2E-X8B2L18-M1TJ 0.3M | E2E-X8C2L18-M1TJ 0.3M |
| | | | NO+NC | E2E-X8B3DL18-M1TJ 0.3M | E2E-X8C3L18-M1TJ 0.3M |
| | M12 Connector | 53 mm | NO | E2E-X8B1D18-M1 | E2E-X8C118-M1 |
| | | | NC | E2E-X8B218-M1 | E2E-X8C218-M1 |
| | | | NO+NC | E2E-X8B3D18-M1 | E2E-X8C318-M1 |
| | | 75 mm | NO | E2E-X8B1DL18-M1 | E2E-X8C1L18-M1 |
| | | | NC | E2E-X8B2L18-M1 | E2E-X8C2L18-M1 |
| | | | NO+NC | E2E-X8B3DL18-M1 | E2E-X8C3L18-M1 |
| M30 (15 mm) | Pre-wired (2 m) *1 | 60 mm *2 | NO | E2E-X15B1D30 2M | E2E-X15C130 2M |
| | | | NC | E2E-X15B230 2M | E2E-X15C230 2M |
| | | | NO+NC | E2E-X15B3D30 2M | E2E-X15C330 2M |
| | | 82 mm | NO | E2E-X15B1DL30 2M | E2E-X15C1L30 2M |
| | | | NC | E2E-X15B2L30 2M | E2E-X15C2L30 2M |
| | | | NO+NC | E2E-X15B3DL30 2M | E2E-X15C3L30 2M |
| | M12 Pre-wired Smartclick Connector (0.3 m) | 60 mm *3 | NO | E2E-X15B1D30-M1TJ 0.3M | E2E-X15C130-M1TJ 0.3M |
| | | | NC | E2E-X15B230-M1TJ 0.3M | E2E-X15C230-M1TJ 0.3M |
| | | | NO+NC | E2E-X15B3D30-M1TJ 0.3M | E2E-X15C330-M1TJ 0.3M |
| | | 82 mm | NO | E2E-X15B1DL30-M1TJ 0.3M | E2E-X15C1L30-M1TJ 0.3M |
| | | | NC | E2E-X15B2L30-M1TJ 0.3M | E2E-X15C2L30-M1TJ 0.3M |
| | | | NO+NC | E2E-X15B3DL30-M1TJ 0.3M | E2E-X15C3L30-M1TJ 0.3M |
| | M12 Connector | 58 mm | NO | E2E-X15B1D30-M1 | E2E-X15C130-M1 |
| | | | NC | E2E-X15B230-M1 | E2E-X15C230-M1 |
| | | | NO+NC | E2E-X15B3D30-M1 | E2E-X15C330-M1 |
| | | 80 mm | NO | E2E-X15B1DL30-M1 | E2E-X15C1L30-M1 |
| | | | NC | E2E-X15B2L30-M1 | E2E-X15C2L30-M1 |
| | | | NO+NC | E2E-X15B3DL30-M1 | E2E-X15C3L30-M1 |

*1. Models with 5-m cable length are also available (Example: E2E-X2B1D8 5M)

*2. Models with 2-m and 5-m robot (bending-resistant) cables are also available with "-R" in the model number. (Example: E2E-X2B1D8-R 2M/ E2E-X2B1D8-R 5M)

*3. Models with M12 Smartclick connector model robot (bending-resistant) cables are also available with "R" in the model number. (Example: E2E-X4B1T12-M1TJR 0.3M)

Note: 1. Models in are equipped with IO-Link (COM2). For IO-Link (COM3), select a model number with the format of "E2E-X□□□T□" (Example: E2E-X2B1T8 2M).

Operation mode NO can be changed to NC via IO-Link communications.

2. IO-Link is not supported for NC-type PNP outputs or all types of NPN outputs.

BASIC Model

E2E NEXT Series (Double distance model)

DC 3-wire [Refer to Dimensions on page 51.]

Unshielded

| Size (Sensing distance) | Connection method | Body size | Operation mode | Model | | |
|--|--|--------------------|----------------|-------------------------|------------------------|-----------------|
| | | | | PNP | NPN | |
| M8 (4 mm) | Pre-wired (2 m) *1 | 38 mm *2 | NO | E2E-X4MB1D8 2M | E2E-X4MC18 2M | |
| | | | NC | E2E-X4MB28 2M | E2E-X4MC28 2M | |
| | | 48 mm | NO | E2E-X4MB1DL8 2M | E2E-X4MC1L8 2M | |
| | | | NC | E2E-X4MB2L8 2M | E2E-X4MC2L8 2M | |
| | M12 Pre-wired Smartclick Connector (0.3 m) | 38 mm *3 | NO | E2E-X4MB1D8-M1TJ 0.3M | E2E-X4MC18-M1TJ 0.3M | |
| | | | NC | E2E-X4MB28-M1TJ 0.3M | E2E-X4MC28-M1TJ 0.3M | |
| | | 48 mm | NO | E2E-X4MB1DL8-M1TJ 0.3M | E2E-X4MC1L8-M1TJ 0.3M | |
| | | | NC | E2E-X4MB2L8-M1TJ 0.3M | E2E-X4MC2L8-M1TJ 0.3M | |
| | M12 Connector | 43 mm | NO | E2E-X4MB1D8-M1 | E2E-X4MC18-M1 | |
| | | | NC | E2E-X4MB28-M1 | E2E-X4MC28-M1 | |
| | | 53 mm | NO | E2E-X4MB1DL8-M1 | E2E-X4MC1L8-M1 | |
| | | | NC | E2E-X4MB2L8-M1 | E2E-X4MC2L8-M1 | |
| | M8 Connector (4-pin) | 39 mm | NO | E2E-X4MB1D8-M3 | E2E-X4MC18-M3 | |
| | | | NC | E2E-X4MB28-M3 | E2E-X4MC28-M3 | |
| | | 49 mm | NO | E2E-X4MB1DL8-M3 | E2E-X4MC1L8-M3 | |
| | | | NC | E2E-X4MB2L8-M3 | E2E-X4MC2L8-M3 | |
| | M8 Connector (3-pin) | 39 mm | NO | E2E-X4MB1D8-M5 | E2E-X4MC18-M5 | |
| | | | NC | E2E-X4MB28-M5 | E2E-X4MC28-M5 | |
| | | 49 mm | NO | E2E-X4MB1DL8-M5 | E2E-X4MC1L8-M5 | |
| | | | NC | E2E-X4MB2L8-M5 | E2E-X4MC2L8-M5 | |
| | M12 (8 mm) | Pre-wired (2 m) *1 | 47 mm *2 | NO | E2E-X8MB1D12 2M | E2E-X8MC112 2M |
| | | | | NC | E2E-X8MB212 2M | E2E-X8MC212 2M |
| | | | | NO+NC | E2E-X8MB3D12 2M | E2E-X8MC312 2M |
| | | | 69 mm | NO | E2E-X8MB1DL12 2M | E2E-X8MC1L12 2M |
| NC | | | | E2E-X8MB2L12 2M | E2E-X8MC2L12 2M | |
| NO+NC | | | | E2E-X8MB3DL12 2M | E2E-X8MC3L12 2M | |
| M12 Pre-wired Smartclick Connector (0.3 m) | | 47 mm *3 | NO | E2E-X8MB1D12-M1TJ 0.3M | E2E-X8MC112-M1TJ 0.3M | |
| | | | NC | E2E-X8MB212-M1TJ 0.3M | E2E-X8MC212-M1TJ 0.3M | |
| | | | NO+NC | E2E-X8MB3D12-M1TJ 0.3M | E2E-X8MC312-M1TJ 0.3M | |
| | | 69 mm | NO | E2E-X8MB1DL12-M1TJ 0.3M | E2E-X8MC1L12-M1TJ 0.3M | |
| | | | NC | E2E-X8MB2L12-M1TJ 0.3M | E2E-X8MC2L12-M1TJ 0.3M | |
| | | | NO+NC | E2E-X8MB3DL12-M1TJ 0.3M | E2E-X8MC3L12-M1TJ 0.3M | |
| M12 Connector | | 48 mm | NO | E2E-X8MB1D12-M1 | E2E-X8MC112-M1 | |
| | | | NC | E2E-X8MB212-M1 | E2E-X8MC212-M1 | |
| | | | NO+NC | E2E-X8MB3D12-M1 | E2E-X8MC312-M1 | |
| | | 70 mm | NO | E2E-X8MB1DL12-M1 | E2E-X8MC1L12-M1 | |
| | | | NC | E2E-X8MB2L12-M1 | E2E-X8MC2L12-M1 | |
| | | | NO+NC | E2E-X8MB3DL12-M1 | E2E-X8MC3L12-M1 | |

E2E/E2EQ NEXT Series

BASIC Model

| Size (Sensing distance) | Connection method | Body size | Operation mode | Model | |
|-------------------------|--|-----------|----------------|--------------------------|-------------------------|
| | | | | PNP | NPN |
| M18 (16 mm) | Pre-wired (2 m) *1 | 55 mm *2 | NO | E2E-X16MB1D18 2M | E2E-X16MC118 2M |
| | | | NC | E2E-X16MB218 2M | E2E-X16MC218 2M |
| | | | NO+NC | E2E-X16MB3D18 2M | E2E-X16MC318 2M |
| | | 77 mm | NO | E2E-X16MB1DL18 2M | E2E-X16MC1L18 2M |
| | | | NC | E2E-X16MB2L18 2M | E2E-X16MC2L18 2M |
| | | | NO+NC | E2E-X16MB3DL18 2M | E2E-X16MC3L18 2M |
| | M12 Pre-wired Smartclick Connector (0.3 m) | 55 mm *3 | NO | E2E-X16MB1D18-M1TJ 0.3M | E2E-X16MC118-M1TJ 0.3M |
| | | | NC | E2E-X16MB218-M1TJ 0.3M | E2E-X16MC218-M1TJ 0.3M |
| | | | NO+NC | E2E-X16MB3D18-M1TJ 0.3M | E2E-X16MC318-M1TJ 0.3M |
| | | 77 mm | NO | E2E-X16MB1DL18-M1TJ 0.3M | E2E-X16MC1L18-M1TJ 0.3M |
| | | | NC | E2E-X16MB2L18-M1TJ 0.3M | E2E-X16MC2L18-M1TJ 0.3M |
| | | | NO+NC | E2E-X16MB3DL18-M1TJ 0.3M | E2E-X16MC3L18-M1TJ 0.3M |
| | M12 Connector | 53 mm | NO | E2E-X16MB1D18-M1 | E2E-X16MC118-M1 |
| | | | NC | E2E-X16MB218-M1 | E2E-X16MC218-M1 |
| | | | NO+NC | E2E-X16MB3D18-M1 | E2E-X16MC318-M1 |
| | | 75 mm | NO | E2E-X16MB1DL18-M1 | E2E-X16MC1L18-M1 |
| | | | NC | E2E-X16MB2L18-M1 | E2E-X16MC2L18-M1 |
| | | | NO+NC | E2E-X16MB3DL18-M1 | E2E-X16MC3L18-M1 |
| M30 (30 mm) | Pre-wired (2 m) *1 | 82 mm *2 | NO | E2E-X30MB1DL30 2M | E2E-X30MC1L30 2M |
| | | | NC | E2E-X30MB2L30 2M | E2E-X30MC2L30 2M |
| | | | NO+NC | E2E-X30MB3DL30 2M | E2E-X30MC3L30 2M |
| | M12 Pre-wired Smartclick Connector (0.3 m) | 82 mm *3 | NO | E2E-X30MB1DL30-M1TJ 0.3M | E2E-X30MC1L30-M1TJ 0.3M |
| | | | NC | E2E-X30MB2L30-M1TJ 0.3M | E2E-X30MC2L30-M1TJ 0.3M |
| | | | NO+NC | E2E-X30MB3DL30-M1TJ 0.3M | E2E-X30MC3L30-M1TJ 0.3M |
| | M12 Connector | 80 mm | NO | E2E-X30MB1DL30-M1 | E2E-X30MC1L30-M1 |
| | | | NC | E2E-X30MB2L30-M1 | E2E-X30MC2L30-M1 |
| | | | NO+NC | E2E-X30MB3DL30-M1 | E2E-X30MC3L30-M1 |

*1. Models with 5-m cable length are also available (Example: E2E-X8MB1D12 5M)

*2. Models with 2-m and 5-m robot (bending-resistant) cables are also available with "-R" in the model number. (Example: E2E-X8MB1D12-R 2M/ E2E-X8MB1D12-R 5M)

*3. Models with M12 Smartclick connector model robot (bending-resistant) cables are also available with "R" in the model number. (Example: E2E-X8MB1D12-M1TJR 0.3M)

Note: 1. Models in are equipped with IO-Link (COM2). For IO-Link (COM3), select a model number with the format of "E2E-X□□□T□" (Example: E2E-X8MB1T12 2M).

Operation mode NO can be changed to NC via IO-Link communications.

2. IO-Link is not supported for NC-type PNP outputs or all types of NPN outputs.

BASIC Model

E2E NEXT Series (Single distance model)

DC 3-wire [Refer to Dimensions on page 51.]

Shielded

| Size (Sensing distance) | Connection method | Body size | Operation mode | Model | | |
|--|--|--------------------|----------------|-------------------------|------------------------|----------------|
| | | | | PNP | NPN | |
| M8 (1.5 mm) | Pre-wired (2 m) *1 | 38 mm *2 | NO | E2E-X1R5B1D8 2M | E2E-X1R5C18 2M | |
| | | | NC | E2E-X1R5B28 2M | E2E-X1R5C28 2M | |
| | | 48 mm | NO | E2E-X1R5B1DL8 2M | E2E-X1R5C1L8 2M | |
| | | | NC | E2E-X1R5B2L8 2M | E2E-X1R5C2L8 2M | |
| | M12 Pre-wired Smartclick Connector (0.3 m) | 38 mm *3 | NO | E2E-X1R5B1D8-M1TJ 0.3M | E2E-X1R5C18-M1TJ 0.3M | |
| | | | NC | E2E-X1R5B28-M1TJ 0.3M | E2E-X1R5C28-M1TJ 0.3M | |
| | | 48 mm | NO | E2E-X1R5B1DL8-M1TJ 0.3M | E2E-X1R5C1L8-M1TJ 0.3M | |
| | | | NC | E2E-X1R5B2L8-M1TJ 0.3M | E2E-X1R5C2L8-M1TJ 0.3M | |
| | M12 Connector | 43 mm | NO | E2E-X1R5B1D8-M1 | E2E-X1R5C18-M1 | |
| | | | NC | E2E-X1R5B28-M1 | E2E-X1R5C28-M1 | |
| | | 53 mm | NO | E2E-X1R5B1DL8-M1 | E2E-X1R5C1L8-M1 | |
| | | | NC | E2E-X1R5B2L8-M1 | E2E-X1R5C2L8-M1 | |
| | M8 Connector (4-pin) | 39 mm | NO | E2E-X1R5B1D8-M3 | E2E-X1R5C18-M3 | |
| | | | NC | E2E-X1R5B28-M3 | E2E-X1R5C28-M3 | |
| | | 49 mm | NO | E2E-X1R5B1DL8-M3 | E2E-X1R5C1L8-M3 | |
| | | | NC | E2E-X1R5B2L8-M3 | E2E-X1R5C2L8-M3 | |
| | M8 Connector (3-pin) | 39 mm | NO | E2E-X1R5B1D8-M5 | E2E-X1R5C18-M5 | |
| | | | NC | E2E-X1R5B28-M5 | E2E-X1R5C28-M5 | |
| | | 49 mm | NO | E2E-X1R5B1DL8-M5 | E2E-X1R5C1L8-M5 | |
| | | | NC | E2E-X1R5B2L8-M5 | E2E-X1R5C2L8-M5 | |
| | M12 (2 mm) | Pre-wired (2 m) *1 | 47 mm *2 | NO | E2E-X2B1D12 2M | E2E-X2C112 2M |
| | | | | NC | E2E-X2B212 2M | E2E-X2C212 2M |
| | | | | NO+NC | E2E-X2B3D12 2M | E2E-X2C312 2M |
| | | | 69 mm | NO | E2E-X2B1DL12 2M | E2E-X2C1L12 2M |
| NC | | | | E2E-X2B2L12 2M | E2E-X2C2L12 2M | |
| NO+NC | | | | E2E-X2B3DL12 2M | E2E-X2C3L12 2M | |
| M12 Pre-wired Smartclick Connector (0.3 m) | | 47 mm *3 | NO | E2E-X2B1D12-M1TJ 0.3M | E2E-X2C112-M1TJ 0.3M | |
| | | | NC | E2E-X2B212-M1TJ 0.3M | E2E-X2C212-M1TJ 0.3M | |
| | | | NO+NC | E2E-X2B3D12-M1TJ 0.3M | E2E-X2C312-M1TJ 0.3M | |
| | | 69 mm | NO | E2E-X2B1DL12-M1TJ 0.3M | E2E-X2C1L12-M1TJ 0.3M | |
| | | | NC | E2E-X2B2L12-M1TJ 0.3M | E2E-X2C2L12-M1TJ 0.3M | |
| | | | NO+NC | E2E-X2B3DL12-M1TJ 0.3M | E2E-X2C3L12-M1TJ 0.3M | |
| M12 Connector | | 48 mm | NO | E2E-X2B1D12-M1 | E2E-X2C112-M1 | |
| | | | NC | E2E-X2B212-M1 | E2E-X2C212-M1 | |
| | | | NO+NC | E2E-X2B3D12-M1 | E2E-X2C312-M1 | |
| | | 70 mm | NO | E2E-X2B1DL12-M1 | E2E-X2C1L12-M1 | |
| | | | NC | E2E-X2B2L12-M1 | E2E-X2C2L12-M1 | |
| | | | NO+NC | E2E-X2B3DL12-M1 | E2E-X2C3L12-M1 | |

E2E/E2EQ NEXT Series

BASIC Model

| Size (Sensing distance) | Connection method | Body size | Operation mode | Model | |
|-------------------------|--|-----------|----------------|-------------------------|------------------------|
| | | | | PNP | NPN |
| M18 (5 mm) | Pre-wired (2 m) *1 | 55 mm *2 | NO | E2E-X5B1D18 2M | E2E-X5C118 2M |
| | | | NC | E2E-X5B218 2M | E2E-X5C218 2M |
| | | | NO+NC | E2E-X5B3D18 2M | E2E-X5C318 2M |
| | | 77 mm | NO | E2E-X5B1DL18 2M | E2E-X5C1L18 2M |
| | | | NC | E2E-X5B2L18 2M | E2E-X5C2L18 2M |
| | | | NO+NC | E2E-X5B3DL18 2M | E2E-X5C3L18 2M |
| | M12 Pre-wired Smartclick Connector (0.3 m) | 55 mm *3 | NO | E2E-X5B1D18-M1TJ 0.3M | E2E-X5C118-M1TJ 0.3M |
| | | | NC | E2E-X5B218-M1TJ 0.3M | E2E-X5C218-M1TJ 0.3M |
| | | | NO+NC | E2E-X5B3D18-M1TJ 0.3M | E2E-X5C318-M1TJ 0.3M |
| | | 77 mm | NO | E2E-X5B1DL18-M1TJ 0.3M | E2E-X5C1L18-M1TJ 0.3M |
| | | | NC | E2E-X5B2L18-M1TJ 0.3M | E2E-X5C2L18-M1TJ 0.3M |
| | | | NO+NC | E2E-X5B3DL18-M1TJ 0.3M | E2E-X5C3L18-M1TJ 0.3M |
| | M12 Connector | 53 mm | NO | E2E-X5B1D18-M1 | E2E-X5C118-M1 |
| | | | NC | E2E-X5B218-M1 | E2E-X5C218-M1 |
| | | | NO+NC | E2E-X5B3D18-M1 | E2E-X5C318-M1 |
| | | 75 mm | NO | E2E-X5B1DL18-M1 | E2E-X5C1L18-M1 |
| | | | NC | E2E-X5B2L18-M1 | E2E-X5C2L18-M1 |
| | | | NO+NC | E2E-X5B3DL18-M1 | E2E-X5C3L18-M1 |
| M30 (10 mm) | Pre-wired (2 m) *1 | 60 mm *2 | NO | E2E-X10B1D30 2M | E2E-X10C130 2M |
| | | | NC | E2E-X10B230 2M | E2E-X10C230 2M |
| | | | NO+NC | E2E-X10B3D30 2M | E2E-X10C330 2M |
| | | 82 mm | NO | E2E-X10B1DL30 2M | E2E-X10C1L30 2M |
| | | | NC | E2E-X10B2L30 2M | E2E-X10C2L30 2M |
| | | | NO+NC | E2E-X10B3DL30 2M | E2E-X10C3L30 2M |
| | M12 Pre-wired Smartclick Connector (0.3 m) | 60 mm *3 | NO | E2E-X10B1D30-M1TJ 0.3M | E2E-X10C130-M1TJ 0.3M |
| | | | NC | E2E-X10B230-M1TJ 0.3M | E2E-X10C230-M1TJ 0.3M |
| | | | NO+NC | E2E-X10B3D30-M1TJ 0.3M | E2E-X10C330-M1TJ 0.3M |
| | | 82 mm | NO | E2E-X10B1DL30-M1TJ 0.3M | E2E-X10C1L30-M1TJ 0.3M |
| | | | NC | E2E-X10B2L30-M1TJ 0.3M | E2E-X10C2L30-M1TJ 0.3M |
| | | | NO+NC | E2E-X10B3DL30-M1TJ 0.3M | E2E-X10C3L30-M1TJ 0.3M |
| | M12 Connector | 58 mm | NO | E2E-X10B1D30-M1 | E2E-X10C130-M1 |
| | | | NC | E2E-X10B230-M1 | E2E-X10C230-M1 |
| | | | NO+NC | E2E-X10B3D30-M1 | E2E-X10C330-M1 |
| | | 80 mm | NO | E2E-X10B1DL30-M1 | E2E-X10C1L30-M1 |
| | | | NC | E2E-X10B2L30-M1 | E2E-X10C2L30-M1 |
| | | | NO+NC | E2E-X10B3DL30-M1 | E2E-X10C3L30-M1 |

*1. Models with 5-m cable length are also available (Example: E2E-X2B1D12 5M)

*2. Models with 2-m and 5-m robot (bending-resistant) cables are also available with "-R" in the model number. (Example: E2E-X2B1D12-R 2M/ E2E-X2B1D12-R 5M)

*3. Models with M12 Smartclick connector model robot (bending-resistant) cables are also available with "R" in the model number. (Example: E2E-X2B1D12-M1TJR 0.3M)

Note: 1. Models in are equipped with IO-Link (COM2). For IO-Link (COM3), select a model number with the format of "E2E-X□□□T□" (Example: E2E-X2B1T12 2M).

Operation mode NO can be changed to NC via IO-Link communications.

2. IO-Link is not supported for NC-type PNP outputs or all types of NPN outputs.

BASIC Model

E2E NEXT Series (Single distance model)

DC 3-wire [Refer to Dimensions on page 51.]

Unshielded

| Size (Sensing distance) | Connection method | Body size | Operation mode | Model | | |
|--|--|--------------------|----------------|-------------------------|------------------------|-----------------|
| | | | | PNP | NPN | |
| M8 (2mm) | Pre-wired (2 m) *1 | 38 mm *2 | NO | E2E-X2MB1D8 2M | E2E-X2MC18 2M | |
| | | | NC | E2E-X2MB28 2M | E2E-X2MC28 2M | |
| | | 48 mm | NO | E2E-X2MB1DL8 2M | E2E-X2MC1L8 2M | |
| | | | NC | E2E-X2MB2L8 2M | E2E-X2MC2L8 2M | |
| | M12 Pre-wired Smartclick Connector (0.3 m) | 38 mm *3 | NO | E2E-X2MB1D8-M1TJ 0.3M | E2E-X2MC18-M1TJ 0.3M | |
| | | | NC | E2E-X2MB28-M1TJ 0.3M | E2E-X2MC28-M1TJ 0.3M | |
| | | 48 mm | NO | E2E-X2MB1DL8-M1TJ 0.3M | E2E-X2MC1L8-M1TJ 0.3M | |
| | | | NC | E2E-X2MB2L8-M1TJ 0.3M | E2E-X2MC2L8-M1TJ 0.3M | |
| | M12 Connector | 43 mm | NO | E2E-X2MB1D8-M1 | E2E-X2MC18-M1 | |
| | | | NC | E2E-X2MB28-M1 | E2E-X2MC28-M1 | |
| | | 53 mm | NO | E2E-X2MB1DL8-M1 | E2E-X2MC1L8-M1 | |
| | | | NC | E2E-X2MB2L8-M1 | E2E-X2MC2L8-M1 | |
| | M8 Connector (4-pin) | 39 mm | NO | E2E-X2MB1D8-M3 | E2E-X2MC18-M3 | |
| | | | NC | E2E-X2MB28-M3 | E2E-X2MC28-M3 | |
| | | 49 mm | NO | E2E-X2MB1DL8-M3 | E2E-X2MC1L8-M3 | |
| | | | NC | E2E-X2MB2L8-M3 | E2E-X2MC2L8-M3 | |
| | M8 Connector (3-pin) | 39 mm | NO | E2E-X2MB1D8-M5 | E2E-X2MC18-M5 | |
| | | | NC | E2E-X2MB28-M5 | E2E-X2MC28-M5 | |
| | | 49 mm | NO | E2E-X2MB1DL8-M5 | E2E-X2MC1L8-M5 | |
| | | | NC | E2E-X2MB2L8-M5 | E2E-X2MC2L8-M5 | |
| | M12 (5mm) | Pre-wired (2 m) *1 | 47 mm *2 | NO | E2E-X5MB1D12 2M | E2E-X5MC112 2M |
| | | | | NC | E2E-X5MB212 2M | E2E-X5MC212 2M |
| | | | | NO+NC | E2E-X5MB3D12 2M | E2E-X5MC312 2M |
| | | | 69 mm | NO | E2E-X5MB1DL12 2M | E2E-X5MC1L12 2M |
| NC | | | | E2E-X5MB2L12 2M | E2E-X5MC2L12 2M | |
| NO+NC | | | | E2E-X5MB3DL12 2M | E2E-X5MC3L12 2M | |
| M12 Pre-wired Smartclick Connector (0.3 m) | | 47 mm *3 | NO | E2E-X5MB1D12-M1TJ 0.3M | E2E-X5MC112-M1TJ 0.3M | |
| | | | NC | E2E-X5MB212-M1TJ 0.3M | E2E-X5MC212-M1TJ 0.3M | |
| | | | NO+NC | E2E-X5MB3D12-M1TJ 0.3M | E2E-X5MC312-M1TJ 0.3M | |
| | | 69 mm | NO | E2E-X5MB1DL12-M1TJ 0.3M | E2E-X5MC1L12-M1TJ 0.3M | |
| | | | NC | E2E-X5MB2L12-M1TJ 0.3M | E2E-X5MC2L12-M1TJ 0.3M | |
| | | | NO+NC | E2E-X5MB3DL12-M1TJ 0.3M | E2E-X5MC3L12-M1TJ 0.3M | |
| M12 Connector | | 48 mm | NO | E2E-X5MB1D12-M1 | E2E-X5MC112-M1 | |
| | | | NC | E2E-X5MB212-M1 | E2E-X5MC212-M1 | |
| | | | NO+NC | E2E-X5MB3D12-M1 | E2E-X5MC312-M1 | |
| | | 70 mm | NO | E2E-X5MB1DL12-M1 | E2E-X5MC1L12-M1 | |
| | | | NC | E2E-X5MB2L12-M1 | E2E-X5MC2L12-M1 | |
| | | | NO+NC | E2E-X5MB3DL12-M1 | E2E-X5MC3L12-M1 | |

E2E/E2EQ NEXT Series

BASIC Model

| Size (Sensing distance) | Connection method | Body size | Operation mode | Model | |
|-------------------------|--|-----------|----------------|--------------------------|-------------------------|
| | | | | PNP | NPN |
| M18 (10mm) | Pre-wired (2 m) *1 | 55 mm *2 | NO | E2E-X10MB1D18 2M | E2E-X10MC118 2M |
| | | | NC | E2E-X10MB218 2M | E2E-X10MC218 2M |
| | | | NO+NC | E2E-X10MB3D18 2M | E2E-X10MC318 2M |
| | | 77 mm | NO | E2E-X10MB1DL18 2M | E2E-X10MC1L18 2M |
| | | | NC | E2E-X10MB2L18 2M | E2E-X10MC2L18 2M |
| | | | NO+NC | E2E-X10MB3DL18 2M | E2E-X10MC3L18 2M |
| | M12 Pre-wired Smartclick Connector (0.3 m) | 55 mm *3 | NO | E2E-X10MB1D18-M1TJ 0.3M | E2E-X10MC118-M1TJ 0.3M |
| | | | NC | E2E-X10MB218-M1TJ 0.3M | E2E-X10MC218-M1TJ 0.3M |
| | | | NO+NC | E2E-X10MB3D18-M1TJ 0.3M | E2E-X10MC318-M1TJ 0.3M |
| | | 77 mm | NO | E2E-X10MB1DL18-M1TJ 0.3M | E2E-X10MC1L18-M1TJ 0.3M |
| | | | NC | E2E-X10MB2L18-M1TJ 0.3M | E2E-X10MC2L18-M1TJ 0.3M |
| | | | NO+NC | E2E-X10MB3DL18-M1TJ 0.3M | E2E-X10MC3L18-M1TJ 0.3M |
| | M12 Connector | 53 mm | NO | E2E-X10MB1D18-M1 | E2E-X10MC118-M1 |
| | | | NC | E2E-X10MB218-M1 | E2E-X10MC218-M1 |
| | | | NO+NC | E2E-X10MB3D18-M1 | E2E-X10MC318-M1 |
| | | 75 mm | NO | E2E-X10MB1DL18-M1 | E2E-X10MC1L18-M1 |
| | | | NC | E2E-X10MB2L18-M1 | E2E-X10MC2L18-M1 |
| | | | NO+NC | E2E-X10MB3DL18-M1 | E2E-X10MC3L18-M1 |
| M30 (18mm) | Pre-wired (2 m) *1 | 60 mm *2 | NO | E2E-X18MB1D30 2M | E2E-X18MC130 2M |
| | | | NC | E2E-X18MB230 2M | E2E-X18MC230 2M |
| | | | NO+NC | E2E-X18MB3D30 2M | E2E-X18MC330 2M |
| | | 82 mm | NO | E2E-X18MB1DL30 2M | E2E-X18MC1L30 2M |
| | | | NC | E2E-X18MB2L30 2M | E2E-X18MC2L30 2M |
| | | | NO+NC | E2E-X18MB3DL30 2M | E2E-X18MC3L30 2M |
| | M12 Pre-wired Smartclick Connector (0.3 m) | 60 mm *3 | NO | E2E-X18MB1D30-M1TJ 0.3M | E2E-X18MC130-M1TJ 0.3M |
| | | | NC | E2E-X18MB230-M1TJ 0.3M | E2E-X18MC230-M1TJ 0.3M |
| | | | NO+NC | E2E-X18MB3D30-M1TJ 0.3M | E2E-X18MC330-M1TJ 0.3M |
| | | 82 mm | NO | E2E-X18MB1DL30-M1TJ 0.3M | E2E-X18MC1L30-M1TJ 0.3M |
| | | | NC | E2E-X18MB2L30-M1TJ 0.3M | E2E-X18MC2L30-M1TJ 0.3M |
| | | | NO+NC | E2E-X18MB3DL30-M1TJ 0.3M | E2E-X18MC3L30-M1TJ 0.3M |
| | M12 Connector | 58 mm | NO | E2E-X18MB1D30-M1 | E2E-X18MC130-M1 |
| | | | NC | E2E-X18MB230-M1 | E2E-X18MC230-M1 |
| | | | NO+NC | E2E-X18MB3D30-M1 | E2E-X18MC330-M1 |
| | | 80 mm | NO | E2E-X18MB1DL30-M1 | E2E-X18MC1L30-M1 |
| | | | NC | E2E-X18MB2L30-M1 | E2E-X18MC2L30-M1 |
| | | | NO+NC | E2E-X18MB3DL30-M1 | E2E-X18MC3L30-M1 |

*1. Models with 5-m cable length are also available (Example: E2E-X5MB1D12 5M)

*2. Models with 2-m and 5-m robot (bending-resistant) cables are also available with "-R" in the model number. (Example: E2E-X5MB1D12-R 2M/ E2E-X5MB1D12-R 5M)

*3. Models with M12 Smartclick connector model robot (bending-resistant) cables are also available with "R" in the model number. (Example: E2E-X5MB1D12-M1TJR 2M)

Note: 1. Models in are equipped with IO-Link (COM2). For IO-Link (COM3), select a model number with the format of "E2E-X□□□T□" (Example: E2E-X5MB1T12 2M).

Operation mode NO can be changed to NC via IO-Link communications.

2. IO-Link is not supported for NC-type PNP outputs or all types of NPN outputs.

BASIC Model

E2EQ NEXT Series (Spatter-resistant Double distance model)

DC 3-wire [Refer to Dimensions on page 51.]

Shielded

| Size (Sensing distance) | Connection method | Body size | Operation mode | Model | |
|-------------------------|--|-----------|----------------|-------------------------|------------------------|
| | | | | PNP | NPN |
| M8 (2 mm) | Pre-wired (2 m) * | 38 mm | NO | E2EQ-X2B1D8 2M | E2EQ-X2C18 2M |
| | | | NC | E2EQ-X2B28 2M | E2EQ-X2C28 2M |
| | | | NO+NC | E2EQ-X2B3D8 2M | E2EQ-X2C32 2M |
| | M12 Pre-wired Smartclick Connector (0.3 m) | 38 mm | NO | E2EQ-X2B1D8-M1TJ 0.3M | E2EQ-X2C18-M1TJ 0.3M |
| | | | NC | E2EQ-X2B28-M1TJ 0.3M | E2EQ-X2C28-M1TJ 0.3M |
| | | | NO+NC | E2EQ-X2B3D8-M1TJ 0.3M | E2EQ-X2C32-M1TJ 0.3M |
| M12 Connector | 43 mm | NO | E2EQ-X2B1D8-M1 | E2EQ-X2C18-M1 | |
| | | NC | E2EQ-X2B28-M1 | E2EQ-X2C28-M1 | |
| | | NO+NC | E2EQ-X2B3D8-M1 | E2EQ-X2C32-M1 | |
| M12 (4 mm) | Pre-wired (2 m) * | 47 mm | NO | E2EQ-X4B1D12 2M | E2EQ-X4C112 2M |
| | | | NC | E2EQ-X4B212 2M | E2EQ-X4C212 2M |
| | | | NO+NC | E2EQ-X4B3D12 2M | E2EQ-X4C312 2M |
| | M12 Pre-wired Smartclick Connector (0.3 m) | 47 mm | NO | E2EQ-X4B1D12-M1TJ 0.3M | E2EQ-X4C112-M1TJ 0.3M |
| | | | NC | E2EQ-X4B212-M1TJ 0.3M | E2EQ-X4C212-M1TJ 0.3M |
| | | | NO+NC | E2EQ-X4B3D12-M1TJ 0.3M | E2EQ-X4C312-M1TJ 0.3M |
| | M12 Connector | 48 mm | NO | E2EQ-X4B1D12-M1 | E2EQ-X4C112-M1 |
| | | | NC | E2EQ-X4B212-M1 | E2EQ-X4C212-M1 |
| | | | NO+NC | E2EQ-X4B3D12-M1 | E2EQ-X4C312-M1 |
| M18 (8 mm) | Pre-wired (2 m) * | 55 mm | NO | E2EQ-X8B1D18 2M | E2EQ-X8C118 2M |
| | | | NC | E2EQ-X8B218 2M | E2EQ-X8C218 2M |
| | | | NO+NC | E2EQ-X8B3D18 2M | E2EQ-X8C318 2M |
| | M12 Pre-wired Smartclick Connector (0.3 m) | 55 mm | NO | E2EQ-X8B1D18-M1TJ 0.3M | E2EQ-X8C118-M1TJ 0.3M |
| | | | NC | E2EQ-X8B218-M1TJ 0.3M | E2EQ-X8C218-M1TJ 0.3M |
| | | | NO+NC | E2EQ-X8B3D18-M1TJ 0.3M | E2EQ-X8C318-M1TJ 0.3M |
| | M12 Connector | 53 mm | NO | E2EQ-X8B1D18-M1 | E2EQ-X8C118-M1 |
| | | | NC | E2EQ-X8B218-M1 | E2EQ-X8C218-M1 |
| | | | NO+NC | E2EQ-X8B3D18-M1 | E2EQ-X8C318-M1 |
| M30 (15 mm) | Pre-wired (2 m) * | 60 mm | NO | E2EQ-X15B1D30 2M | E2EQ-X15C130 2M |
| | | | NC | E2EQ-X15B230 2M | E2EQ-X15C230 2M |
| | | | NO+NC | E2EQ-X15B3D30 2M | E2EQ-X15C330 2M |
| | M12 Pre-wired Smartclick Connector (0.3 m) | 60 mm | NO | E2EQ-X15B1D30-M1TJ 0.3M | E2EQ-X15C130-M1TJ 0.3M |
| | | | NC | E2EQ-X15B230-M1TJ 0.3M | E2EQ-X15C230-M1TJ 0.3M |
| | | | NO+NC | E2EQ-X15B3D30-M1TJ 0.3M | E2EQ-X15C330-M1TJ 0.3M |
| | M12 Connector | 58 mm | NO | E2EQ-X15B1D30-M1 | E2EQ-X15C130-M1 |
| | | | NC | E2EQ-X15B230-M1 | E2EQ-X15C230-M1 |
| | | | NO+NC | E2EQ-X15B3D30-M1 | E2EQ-X15C330-M1 |

* Models with 5-m cable length are also available (Example: E2EQ-X6B1D12 5M)

Note: 1. Models in are equipped with IO-Link (COM2). For IO-Link (COM3), select a model number with the format of "E2E-X□□□□□"
(Example: E2EQ-X6B1T12 2M).

Operation mode NO can be changed to NC via IO-Link communications.

2. IO-Link is not supported for NC-type PNP outputs or all types of NPN outputs.

E2E/E2EQ NEXT Series

BASIC Model

E2EQ NEXT Series (Spatter-resistant Single distance model)

DC 3-wire [Refer to Dimensions on page 51.]

Shielded

| Size (Sensing distance) | Connection method | Body size | Operation mode | Model | |
|-------------------------|--|-----------|----------------|-------------------------|------------------------|
| | | | | PNP | NPN |
| M8 (1.5 mm) | Pre-wired (2 m) * | 38 mm | NO | E2EQ-X1R5B1D8 2M | E2EQ-X1R5C18 2M |
| | | | NC | E2EQ-X1R5B28 2M | E2EQ-X1R5C28 2M |
| | M12 Pre-wired Smartclick Connector (0.3 m) | 38 mm | NO | E2EQ-X1R5B1D8-M1TJ 0.3M | E2EQ-X1R5C18-M1TJ 0.3M |
| | | | NC | E2EQ-X1R5B28-M1TJ 0.3M | E2EQ-X1R5C28-M1TJ 0.3M |
| | M12 Connector | 43 mm | NO | E2EQ-X1R5B1D8-M1 | E2EQ-X1R5C18-M1 |
| | | | NC | E2EQ-X1R5B28-M1 | E2EQ-X1R5C28-M1 |
| M12 (2 mm) | Pre-wired (2 m) * | 47 mm | NO | E2EQ-X2B1D12 2M | E2EQ-X2C112 2M |
| | | | NC | E2EQ-X2B212 2M | E2EQ-X2C212 2M |
| | | | NO+NC | E2EQ-X2B3D12 2M | E2EQ-X2C312 2M |
| | M12 Pre-wired Smartclick Connector (0.3 m) | 47 mm | NO | E2EQ-X2B1D12-M1TJ 0.3M | E2EQ-X2C112-M1TJ 0.3M |
| | | | NC | E2EQ-X2B212-M1TJ 0.3M | E2EQ-X2C212-M1TJ 0.3M |
| | | | NO+NC | E2EQ-X2B3D12-M1TJ 0.3M | E2EQ-X2C312-M1TJ 0.3M |
| | M12 Connector | 48 mm | NO | E2EQ-X2B1D12-M1 | E2EQ-X2C112-M1 |
| | | | NC | E2EQ-X2B212-M1 | E2EQ-X2C212-M1 |
| | | | NO+NC | E2EQ-X2B3D12-M1 | E2EQ-X2C312-M1 |
| M18 (5 mm) | Pre-wired (2 m) * | 55 mm | NO | E2EQ-X5B1D18 2M | E2EQ-X5C118 2M |
| | | | NC | E2EQ-X5B218 2M | E2EQ-X5C218 2M |
| | | | NO+NC | E2EQ-X5B3D18 2M | E2EQ-X5C318 2M |
| | M12 Pre-wired Smartclick Connector (0.3 m) | 55 mm | NO | E2EQ-X5B1D18-M1TJ 0.3M | E2EQ-X5C118-M1TJ 0.3M |
| | | | NC | E2EQ-X5B218-M1TJ 0.3M | E2EQ-X5C218-M1TJ 0.3M |
| | | | NO+NC | E2EQ-X5B3D18-M1TJ 0.3M | E2EQ-X5C318-M1TJ 0.3M |
| | M12 Connector | 53 mm | NO | E2EQ-X5B1D18-M1 | E2EQ-X5C118-M1 |
| | | | NC | E2EQ-X5B218-M1 | E2EQ-X5C218-M1 |
| | | | NO+NC | E2EQ-X5B3D18-M1 | E2EQ-X5C318-M1 |
| M30 (10 mm) | Pre-wired (2 m) * | 60 mm | NO | E2EQ-X10B1D30 2M | E2EQ-X10C130 2M |
| | | | NC | E2EQ-X10B230 2M | E2EQ-X10C230 2M |
| | | | NO+NC | E2EQ-X10B3D30 2M | E2EQ-X10C330 2M |
| | M12 Pre-wired Smartclick Connector (0.3 m) | 60 mm | NO | E2EQ-X10B1D30-M1TJ 0.3M | E2EQ-X10C130-M1TJ 0.3M |
| | | | NC | E2EQ-X10B230-M1TJ 0.3M | E2EQ-X10C230-M1TJ 0.3M |
| | | | NO+NC | E2EQ-X10B3D30-M1TJ 0.3M | E2EQ-X10C330-M1TJ 0.3M |
| | M12 Connector | 58 mm | NO | E2EQ-X10B1D30-M1 | E2EQ-X10C130-M1 |
| | | | NC | E2EQ-X10B230-M1 | E2EQ-X10C230-M1 |
| | | | NO+NC | E2EQ-X10B3D30-M1 | E2EQ-X10C330-M1 |

* Models with 5-m cable length are also available (Example: E2EQ-X6B1D12 5M)

Note: 1. Models in are equipped with IO-Link (COM2). For IO-Link (COM3), select a model number with the format of "E2E-X□□□T□" (Example: E2EQ-X6B1T12 2M).

Operation mode NO can be changed to NC via IO-Link communications.

2. IO-Link is not supported for NC-type PNP outputs or all types of NPN outputs.

Accessories (Sold Separately)

Sensor I/O Connectors



(Models for Pre-wired Connectors) A Sensor I/O Connector is not provided with the Sensor. It must be ordered separately as required.

Round Oil-resistant Connectors XS5 NEXT series

| Appearance | Cable specification | Type | Cable diameter (mm) | Cable connection direction | Cable length (m) | Sensor I/O Connector model number | Applicable Proximity Sensor model number |
|--|-------------------------------|-------------------------------|---------------------|---------------------------------------|------------------|-----------------------------------|--|
|  <p>M12 Smartclick Connector Models Straight type</p> | Oil-resistant PVC cable | Sockets on One Cable End | 6 dia. | Straight | 1 | XS5F-D421-C80-X | E2E-X□□□-M1TJ(R) E2EQ-X□□□-M1TJ E2E(Q)-X□□□-M1 |
| | | | | | 2 | XS5F-D421-D80-X | |
| | | | | | 3 | XS5F-D421-E80-X | |
| | | | | | 5 | XS5F-D421-G80-X | |
| | | | | | 10 | XS5F-D421-J80-X | |
| | Oil-resistant PVC robot cable | Sockets on One Cable End | 6 dia. | Straight | 1 | XS5F-D421-C80-XR | |
| | | | | | 2 | XS5F-D421-D80-XR | |
| | | | | | 3 | XS5F-D421-E80-XR | |
| | | | | | 5 | XS5F-D421-G80-XR | |
| | | | | | 10 | XS5F-D421-J80-XR | |
| | Oil-resistant PVC cable | Socket and Plug on Cable Ends | 6 dia. | Straight (Socket)/ Straight (Plug) | 1 | XS5W-D421-C81-X | |
| | | | | | 2 | XS5W-D421-D81-X | |
| | | | | | 3 | XS5W-D421-E81-X | |
| | | | | | 5 | XS5W-D421-G81-X | |
| | | | | | 10 | XS5W-D421-J81-X | |
| | Oil-resistant PVC robot cable | Socket and Plug on Cable Ends | 6 dia. | Straight (Socket)/ Straight (Plug) | 1 | XS5W-D421-C81-XR | |
| | | | | | 2 | XS5W-D421-D81-XR | |
| | | | | | 3 | XS5W-D421-E81-XR | |
| 5 | | | | | XS5W-D421-G81-XR | | |
| 10 | | | | | XS5W-D421-J81-XR | | |

Note: For details of the connector, refer to XS5 NEXT Series on page 87.



Round Water-resistant Connectors XS5 series

| Appearance | Cable Specification | Type | Cable diameter (mm) | Cable Connection Direction | Cable length (m) | Sensor I/O Connector model number | Applicable Proximity Sensor model number | |
|--|---------------------|-------------------------------|---------------------|---|--|-----------------------------------|--|-----------------|
|  <p>M12 Smartclick Connector Straight type</p>  <p>Right-angle type</p> | PVC cable | Sockets on One Cable End | 6 dia. | Straight | 1 | XS5F-D421-C80-F | E2E-X□□□-M1TJ(R) E2EQ-X□□□-M1TJ E2E(Q)-X□□□-M1 | |
| | | | | | 2 | XS5F-D421-D80-F | | |
| | | | | | 3 | XS5F-D421-E80-F | | |
| | | | | | 5 | XS5F-D421-G80-F | | |
| | | | | | 10 | XS5F-D421-J80-F | | |
| | | | | Right-angle | 1 | XS5F-D422-C80-F | | |
| | | | | | 2 | XS5F-D422-D80-F | | |
| | | | | | 3 | XS5F-D422-E80-F | | |
| | | | | | 5 | XS5F-D422-G80-F | | |
| | | | | | 10 | XS5F-D422-J80-F | | |
| | PVC robot cable | Socket and Plug on Cable Ends | 6 dia. | Straight (Socket)/ Straight (Plug) | 1 | XS5W-D421-C81-F | | |
| | | | | | 2 | XS5W-D421-D81-F | | |
| | | | | | 3 | XS5W-D421-E81-F | | |
| | | | | | 5 | XS5W-D421-G81-F | | |
| | | | | Right-angle (Socket)/ Right-angle (Plug) | 2 | XS5W-D422-D81-F | | |
| | | | | | 5 | XS5W-D422-G81-F | | |
| | | | | | Straight (Socket)/ Right-angle (Plug) | 2 | | XS5W-D423-D81-F |
| | | | | | | 5 | | XS5W-D423-G81-F |
| Right-angle (Socket)/ Straight (Plug) | 2 | XS5W-D424-D81-F | | | | | | |
| | 5 | XS5W-D424-G81-F | | | | | | |

Note: For details of the connector, refer to XS5 Series on page 94.

E2E/E2EQ NEXT Series

Round Water-resistant Connectors XS3W-M8/XS3F-M8 series

| Appearance | Cable specification | Type | Cable diameter (mm) | No. of cable cores (Poles) | Cable connection direction | Cable length (m) | Sensor I/O Connector model number | Applicable Proximity Sensor model number |
|--|---------------------|---|---------------------|----------------------------|--|------------------|-----------------------------------|--|
| M8 Connector Straight type  | PVC cable | Sockets on One Cable End | 5 dia. | 3 | Straight | 2 | XS3F-M8PVC3S2M | E2E-X□□□-M5 |
| | | | | | | 5 | XS3F-M8PVC3S5M | |
| | | | | | | 10 | XS3F-M8PVC3S10M | |
| | | | | | Right-angle | 2 | XS3F-M8PVC3A2M | |
| | | | | | | 5 | XS3F-M8PVC3A5M | |
| | | | | | | 10 | XS3F-M8PVC3A10M | |
| | | Right-angle type  | | 4 | Straight | 2 | XS3F-M8PVC4S2M | E2E-X□□□-M3 |
| | | | | | | 5 | XS3F-M8PVC4S5M | |
| | | | | | | 10 | XS3F-M8PVC4S10M | |
| | | | | | Right-angle | 2 | XS3F-M8PVC4A2M | |
| | | | | | | 5 | XS3F-M8PVC4A5M | |
| | | | | | | 10 | XS3F-M8PVC4A10M | |
| | | Socket and Plug on Cable Ends | 5 dia. | 3 | Straight (Plug)/ Straight (Socket) | 2 | XS3W-M8PVC3SS2M | E2E-X□□□-M5 |
| | | | | | | 5 | XS3W-M8PVC3SS5M | |
| | | | | | | 10 | XS3W-M8PVC3SS10M | |
| | | | | | Straight (Plug)/ Right-angle (Socket) | 2 | XS3W-M8PVC3SA2M | |
| | | | | | | 5 | XS3W-M8PVC3SA5M | |
| | | | | | | 10 | XS3W-M8PVC3SA10M | |
| | | Straight (Plug)/ Straight (Socket) Straight (Plug)/ Right-angle (Socket) | | 4 | Straight (Plug)/ Straight (Socket) | 2 | XS3W-M8PVC4SS2M | E2E-X□□□-M3 |
| | | | | | | 5 | XS3W-M8PVC4SS5M | |
| | | | | | | 10 | XS3W-M8PVC4SS10M | |
| | | | | | Straight (Plug)/ Right-angle (Socket) | 2 | XS3W-M8PVC4SA2M | |
| | | | | | | 5 | XS3W-M8PVC4SA5M | |
| | | | | | | 10 | XS3W-M8PVC4SA10M | |

Note: For details of the connector, refer to XS3W-M8/XS3F-M8 Series on page 102.

Sensor I/O Connectors Oil resistance performance of mating combination

| E2E NEXT Series | | Applicable connector Model | | |
|-----------------------------|-----------------|----------------------------|------------------------|------------------------|
| Connecting method | Model | XS5 NEXT Series | XS5 Series | XS3W-M8/XS3F-M8 Series |
| Pre-wired Connector Models | E2E-X□□-M1TJ(R) | Oil resistant (2 years) * | Water-resistant (IP67) | --- |
| M12 Connector Models | E2E-X□□-M1 | Water-resistant (IP67) | Water-resistant (IP67) | --- |
| M8 Connector (4-pin) Models | E2E-X□□-M3 | --- | --- | Water-resistant (IP67) |
| M8 Connector (3-pin) Models | E2E-X□□-M5 | --- | --- | Water-resistant (IP67) |

* Applicable cutting oil type: specified in JIS K 2241:2000

2 years of oil resistance indicates the median value of the product design and the oil-resistance performance criterion result (=Typical value). Products to be shipped will have around 2 years of oil resistance, but will vary depending on the product.

Quick fix (Mounting Sleeves) [Refer to Dimensions on page 52.]

A Mounting Bracket is not provided with the Sensor. It must be ordered separately as required.

Only applicable to standard body-sized E2E NEXT Series Sensors.

| Appearance | Model | Applicable Sensors |
|---|-------------|-------------------------------|
|  | Y92E-J8S12 | E2E NEXT M8 Shielded Sensors |
| | Y92E-J12S18 | E2E NEXT M12 Shielded Sensors |
| | Y92E-J18S30 | E2E NEXT M18 Shielded Sensors |

Note: Not applicable for E2E NEXT Series long-body models and E2EQ NEXT Series (spatter-resistant) models.

Ratings and Specifications

PREMIUM Model

E2E NEXT Series (Quadruple/Triple distance model)
DC 3-wire
Shielded

| Types Size Model | Quadruple distance model | | | | Triple distance model | | | | |
|--|---|---|----------------------|----------------------|---|---|----------------------|----------------------|---------------|
| | M8 | M12 | M18 | M30 | M8 | M12 | M18 | M30 | |
| Item | E2E-X4□8 | E2E-X9□12 | E2E-X14□18 | E2E-X23□30 | E2E-X3□8 | E2E-X6□12 | E2E-X12□18 | E2E-X22□30 | |
| Sensing distance | 4 mm±10% | 9 mm±10% | 14 mm±10% | 23 mm±10% | 3 mm±10% | 6 mm±10% | 12 mm±10% | 22 mm±10% | |
| Setting distance | 0 to 3 mm | 0 to 6.8 mm | 0 to 10.6 mm | 0 to 17.6 mm | 0 to 2.4 mm | 0 to 4.8 mm | 0 to 9.6 mm | 0 to 16.8 mm | |
| Differential travel | 15% max. of sensing distance | | | | | | | | |
| Detectable object | Ferrous metals (For non-ferrous metals, refer to the <i>Engineering Data</i> on page 34.) | | | | | | | | |
| Standard sensing object | Iron, 12 × 12 × 1 mm | Iron, 27 × 27 × 1 mm | Iron, 42 × 42 × 1 mm | Iron, 69 × 69 × 1 mm | Iron, 9 × 9 × 1 mm | Iron, 18 × 18 × 1 mm | Iron, 36 × 36 × 1 mm | Iron, 66 × 66 × 1 mm | |
| Response frequency *1 | 700 Hz | 700 Hz | 350 Hz | 200 Hz | 1,000 Hz | 800 Hz | 500 Hz | 200 Hz | |
| Power supply voltage | 10 to 30 VDC (including 10% ripple (p-p)), Class 2 | | | | | | | | |
| Current consumption | 1-output models: 16 mA max. | | | | | 1-output models: 16 mA max., 2-output models: 20 mA max. | | | |
| Output configuration | B□ Models: PNP open collector, C□ Models: NPN open collector | | | | | | | | |
| Operation mode (with sensing object approaching) | 1-output models (B1, C1): NO (Normally open), 1-output models (B2, C2): NC (Normally closed) | | | | | 1-output models (B1, C1): NO (Normally open), 1-output models (B2, C2): NC (Normally closed), 2-output models (B3, C3): NO+NC (Normally open, Normally closed) | | | |
| Control output | Load current | 1-output models: 10 to 30 VDC, Class 2, 50 mA max. | | | 1-output models: 10 to 30 VDC, Class 2, 100 mA max. | 1-output models: 10 to 30 VDC, Class 2, 100 mA max., 2-output models: 10 to 30 VDC, Class 2, 50 mA max. | | | |
| | Residual voltage | 1-output models: 2 V max. (Load current: 50 mA, Cable length: 2 m) | | | 1-output models: 2 V max. (Load current: 100 mA, Cable length: 2 m) | 1-output models: 2 V max. (Load current: 100 mA, Cable length: 2 m), 2-output models: 2 V max. (Load current: 50 mA, Cable length: 2 m) | | | |
| Indicator *2 | In the Standard I/O mode (SIO mode): Operation indicator (orange, lit) and communication indicator (green, not lit) In the IO-Link communication mode (COM mode): Operation indicator (orange, lit) and communication indicator (green, blinking at 1 s intervals) | | | | | | | | |
| Protection circuits | Power supply reverse polarity protection, Surge suppressor, Output short-circuit protection, Output reverse polarity protection | | | | | | | | |
| Ambient temperature range | Operating: -25 to 60°C Storage: -25 to 70°C (with no icing or condensation) | Operating/Storage: -25 to 70°C (with no icing or condensation) | | | | | | | |
| Ambient humidity range | Operating/Storage: 35% to 95% (with no condensation) | | | | | | | | |
| Temperature influence | -15% to 25% max. of sensing distance at 23°C in the temperature range of -25 to 60°C | ±15% max. of sensing distance at 23°C in the temperature range of -25 to 70°C | | | ±10% max. of sensing distance at 23°C in the temperature range of -25 to 70°C | | | | |
| Voltage influence | ±1% max. of sensing distance at rated voltage in the rated voltage ±15% range | | | | | | | | |
| Insulation resistance | 50 MΩ min. (at 500 VDC) between current-carrying parts and case | | | | | | | | |
| Dielectric strength | 1,000 VAC, 50/60 Hz for 1 minute between current-carrying parts and case | | | | | | | | |
| Vibration resistance (destruction) | 10 to 55 Hz, 1.5-mm double amplitude for 2 hours each in X, Y, and Z directions | | | | | | | | |
| Shock resistance (destruction) | 500 m/s ² 10 times each in X, Y, and Z directions | 1,000 m/s ² 10 times each in X, Y, and Z directions | | | 500 m/s ² 10 times each in X, Y, and Z directions | 1,000 m/s ² 10 times each in X, Y, and Z directions | | | |
| Degree of protection | Pre-wired Models, Pre-wired Connector Models: IEC 60529: IP67, ISO 20653 (old standard: DIN 40050 PART9): IP69K, JIS C 0920 Annex 1: IP67G, Passed OMRON's Oil-resistant Component Evaluation Standards *3 (Cutting oil type: specified in JIS K 2241: 2000; Temperature: 35°C max.) Connector Models: IEC 60529: IP67, ISO 20653 (old standard: DIN 40050 PART9): IP69K | | | | | | | | |
| Connection method | Pre-wired Models (Standard cable length: 2 m), Pre-wired Connector Models (Standard cable length: 0.3 m) and Connector Models (M12 Connector, M8 (4-pin) Connector and M8 (3-pin) Connector) | | | | | | | | |
| Weight *4 (packed state) | Pre-wired | Approx. 85 g | Approx. 95 g | Approx. 180 g | Approx. 260 g | Approx. 85 g | Approx. 95 g | Approx. 180 g | Approx. 260 g |
| | M12 Pre-wired Smartclick Connector | Approx. 55 g | Approx. 70 g | Approx. 115 g | Approx. 200 g | Approx. 55 g | Approx. 70 g | Approx. 115 g | Approx. 200 g |
| | Connector | Approx. 40 g *5 | Approx. 55 g | Approx. 95 g | Approx. 180 g | Approx. 40 g *5 | Approx. 55 g | Approx. 95 g | Approx. 180 g |

E2E/E2EQ NEXT Series

| Item | Types Size | Quadruple distance model | | | | Triple distance model | | | |
|---|--|---|-----------|------------|------------|-----------------------|-----------|------------|------------|
| | | M8 | M12 | M18 | M30 | M8 | M12 | M18 | M30 |
| | Model | E2E-X4□8 | E2E-X9□12 | E2E-X14□18 | E2E-X23□30 | E2E-X3□8 | E2E-X6□12 | E2E-X12□18 | E2E-X22□30 |
| Materials | Case | Nickel-plated brass | | | | | | | |
| | Sensing surface | Polybutylene terephthalat (PBT) | | | | | | | |
| | Clamping nuts | Nickel-plated brass | | | | | | | |
| | Toothed washers | Zinc-plated iron | | | | | | | |
| | Cable | Vinyl chloride (PVC) | | | | | | | |
| Main IO-Link functions*2 | Operation mode switching between NO and NC, sensor internals failure alert, excessive target proximity alarm selection, control output timer function selection (ON delay, OFF delay, One shot options), instability detection alarm with ON delay timer selection, monitor output strength, operating hours read-out, readout of the sensor internal temperature, and factory reset | | | | | | | | |
| IO-Link Communication specifications *2 | IO-Link specification | Ver 1.1 | | | | | | | |
| | Baud rate | COM2 (38.4 kbps), COM3 (230.4 kbps) | | | | | | | |
| | Data length | PD size: 2 bytes, OD size: 1 byte (M-sequence type: TYPE_2_2) | | | | | | | |
| | Minimum cycle time | COM2: 2.3 ms, COM3: 0.4 ms | | | | | | | |
| Accessories | Instruction manual, Clamping nuts, Toothed washer | | | | | | | | |

*1. The response frequency is an average value. Measurement conditions are as follows: standard sensing object, a distance of twice the standard sensing object, and a set distance of half the sensing distance.

*2. IO-Link is not supported for NC-type PNP outputs or all types of NPN outputs.

*3. The Oil-resistant Component Evaluation Standards are OMRON's own durability evaluation standards.

2-year oil resistance indicates the median value of the product design and the oil-resistance performance criterion result (=Typical value).
The Pre-wired Connector Model verifies 2 years of oil resistance when mating with Round Oil-resistant Connectors XS5 NEXT series correctly.
The degree of protection is not satisfied with the part where cable wires are uncovered for the Pre-wired Models.

*4. Weight of the standard body-sized model.

*5. Both M8 connectors and M12 connectors are available.

PREMIUM Model

E2E NEXT Series (Quadruple/Triple distance model)
DC 3-wire
Unshielded

| Item | Types Size Model | Quadruple distance model | | | | Triple distance model | | | | |
|--|------------------------------------|--|----------------------|--|------------------------|---|---|--|------------------------|--|
| | | M8 | M12 | M18 | M30 | M8 | M12 | M18 | M30 | |
| | | E2E-X8M□8 | E2E-X16M□12 | E2E-X30M□18 | E2E-X50M□30 | E2E-X6M□8 | E2E-X10M□12 | E2E-X20M□18 | E2E-X40M□30 | |
| Sensing distance | | 8 mm±10% | 16 mm±10% | 30 mm±10% | 50 mm±10% | 6 mm±10% | 10 mm±10% | 20 mm±10% | 40 mm±10% | |
| Setting distance | | 0 to 6 mm | 0 to 12.2 mm | 0 to 23 mm | 0 to 38.2 mm | 0 to 4.8 mm | 0 to 8 mm | 0 to 16 mm | 0 to 32 mm | |
| Differential travel | | 15% max. of sensing distance | | | | | | | | |
| Detectable object | | Ferrous metals (For non-ferrous metals, refer to the <i>Engineering Data</i> on page 34.) | | | | | | | | |
| Standard sensing object | | Iron, 24 × 24 × 1 mm | Iron, 48 × 48 × 1 mm | Iron, 90 × 90 × 1 mm | Iron, 150 × 150 × 1 mm | Iron, 18 × 18 × 1 mm | Iron, 30 × 30 × 1 mm | Iron, 60 × 60 × 1 mm | Iron, 120 × 120 × 1 mm | |
| Response frequency *1 | | 500 Hz | 400 Hz | 200 Hz | 100 Hz | 800 Hz | 400 Hz | 200 Hz | 100 Hz | |
| Power supply voltage | | 10 to 30 VDC (including 10% ripple (p-p)), Class 2 | | | | | | | | |
| Current consumption | | 1-output models: 16 mA max. | | | | | 1-output models: 16 mA max., 2-output models: 20 mA max. | | | |
| Output configuration | | B□ Models: PNP open collector C□ Models: NPN open collector | | | | | | | | |
| Operation mode (with sensing object approaching) | | 1-output models (B1, C1): NO (Normally open), 1-output models (B2, C2): NC (Normally closed) | | | | | 1-output models (B1, C1): NO (Normally open), 1-output models (B2, C2): NC (Normally closed), 2-output models (B3, C3): NO+NC (Normally open, Normally closed) | | | |
| Control output | Load current | 1-output models: 10 to 30 VDC, Class 2, 50 mA max. | | | | 1-output models: 10 to 30 VDC, Class 2, 100 mA max. | | 1-output models: 10 to 30 VDC, Class 2, 100 mA max., 2-output models: 10 to 30 VDC, Class 2, 50 mA max. | | |
| | Residual voltage | 1-output models: 2 V max. (Load current: 50 mA, Cable length: 2 m) | | | | 1-output models: 2 V max. (Load current: 100 mA, Cable length: 2 m) | | 1-output models: 2 V max. (Load current: 100 mA, Cable length: 2 m), 2-output models: 2 V max. (Load current: 50 mA, Cable length: 2 m) | | |
| Indicator *2 | | In the Standard I/O mode (SIO mode): Operation indicator (orange, lit) and communication indicator (green, not lit) In the IO-Link communication mode (COM mode): Operation indicator (orange, lit) and communication indicator (green, blinking at 1 s intervals) | | | | | | | | |
| Protection circuits | | Power supply reverse polarity protection, Surge suppressor, Output short-circuit protection, Output reverse polarity protection | | | | | | | | |
| Ambient temperature range | | Operating/Storage: -25 to 70°C (with no icing or condensation) | | | | | | | | |
| Ambient humidity range | | Operating/Storage: 35% to 95% (with no condensation) | | | | | | | | |
| Temperature influence | | ±15% max. of sensing distance at 23°C in the temperature range of -25 to 70°C | | | | ±10% max. of sensing distance at 23°C in the temperature range of -25 to 70°C | | | | |
| Voltage influence | | ±1% max. of sensing distance at rated voltage in the rated voltage ±15% range | | | | | | | | |
| Insulation resistance | | 50 MΩ min. (at 500 VDC) between current-carrying parts and case | | | | | | | | |
| Dielectric strength | | 1,000 VAC, 50/60 Hz for 1 minute between current-carrying parts and case | | | | | | | | |
| Vibration resistance (destruction) | | 10 to 55 Hz, 1.5-mm double amplitude for 2 hours each in X, Y, and Z directions | | | | | | | | |
| Shock resistance (destruction) | | 500 m/s ² 10 times each in X, Y, and Z directions | | 1,000 m/s ² 10 times each in X, Y, and Z directions | | 500 m/s ² 10 times each in X, Y, and Z directions | | 1,000 m/s ² 10 times each in X, Y, and Z directions | | |
| Degree of protection | | Pre-wired Models, Pre-wired Connector Models: IEC 60529:IP67, ISO 20653 (old standard: DIN 40050 PART9): IP69K, JIS C 0920 Annex 1: IP67G, Passed OMRON's Oil-resistant Component Evaluation Standards *3 (Cutting oil type: specified in JIS K 2241: 2000; Temperature: 35°C max.) Connector Models: IEC 60529: IP67, ISO 20653 (old standard: DIN 40050 PART9): IP69K | | | | | | | | |
| Connection method | | Pre-wired Models (Standard cable length: 2 m), Pre-wired Connector Models (Standard cable length: 0.3 m) and Connector Models (M12 Connector, M8 (4-pin) Connector and M8 (3-pin) Connector) | | | | | | | | |
| Weight *4 (packed state) | Pre-wired | Approx. 85 g | Approx. 95 g | Approx. 190 g | Approx. 310 g | Approx. 85 g | Approx. 95 g | Approx. 190 g | Approx. 280 g | |
| | M12 Pre-wired Smartclick Connector | Approx. 55 g | Approx. 70 g | Approx. 125 g | Approx. 250 g | Approx. 55 g | Approx. 70 g | Approx. 125 g | Approx. 220 g | |
| | Connector | Approx. 40 g *5 | Approx. 55 g | Approx. 105 g | Approx. 230 g | Approx. 40 g *5 | Approx. 55 g | Approx. 105 g | Approx. 200 g | |

E2E/E2EQ NEXT Series

| Item | Types Size Model | Quadruple distance model | | | | Triple distance model | | | |
|--|------------------------|--|---------------------|-------------|-------------|-----------------------|---------------------|-------------|-------------|
| | | M8 | M12 | M18 | M30 | M8 | M12 | M18 | M30 |
| | | E2E-X8M□8 | E2E-X16M□12 | E2E-X30M□18 | E2E-X50M□30 | E2E-X6M□8 | E2E-X10M□12 | E2E-X20M□18 | E2E-X40M□30 |
| Materials | Case | Stainless (SUS303) | Nickel-plated brass | | | Stainless (SUS303) | Nickel-plated brass | | |
| | Sensing surface | Polybutylene terephthalat (PBT) | | | | | | | |
| | Clamping nuts | Nickel-plated brass | | | | | | | |
| | Toothed washers | Zinc-plated iron | | | | | | | |
| | Cable | Vinyl chloride (PVC) | | | | | | | |
| Main IO-Link functions*2 | | Operation mode switching between NO and NC, sensor internals failure alert, excessive target proximity alarm selection, control output timer function selection (ON delay, OFF delay, One shot options), instability detection alarm with ON delay timer selection, monitor output strength, operating hours read-out, readout of the sensor internal temperature, and factory reset | | | | | | | |
| IO-Link Communication specifications*2 | IO-Link specification | Ver1.1 | | | | | | | |
| | Baud rate | COM2 (38.4 kbps), COM3 (230.4 kbps) | | | | | | | |
| | Data length | PD size: 2 bytes, OD size: 1 byte (M-sequence type: TYPE_2_2) | | | | | | | |
| | Minimum cycle time | COM2: 2.3 ms, COM3: 0.4 ms | | | | | | | |
| Accessories | | Instruction manual, Clamping nuts, Toothed washer | | | | | | | |

*1. The response frequency is an average value. Measurement conditions are as follows: standard sensing object, a distance of twice the standard sensing object, and a set distance of half the sensing distance.

*2. IO-Link is not supported for NC-type PNP outputs or all types of NPN outputs.

*3. The Oil-resistant Component Evaluation Standards are OMRON's own durability evaluation standards. 2-year oil resistance indicates the median value of the product design and the oil-resistance performance criterion result (=Typical value). Actual performance can be expected to decline after two years on average from shipment. The Pre-wired Connector Model verifies 2 years of oil resistance when mating with Round Oil-resistant Connectors XS5 NEXT series correctly. The degree of protection is not satisfied with the part where cable wires are uncovered for the Pre-wired Models.

*4. Weight of the standard body-sized model.

*5. Both M8 connectors and M12 connectors are available.

PREMIUM Model

E2EQ NEXT Series (Spatter-resistant Triple distance model)
DC 3-wire
Shielded

| Item | Types Size Model | Triple distance Models | | | |
|--|------------------------------------|--|--|----------------------|----------------------|
| | | M8 | M12 | M18 | M30 |
| | | E2EQ-X3□8 | E2EQ-X6□12 | E2EQ-X12□18 | E2EQ-X22□30 |
| Sensing distance | | 3 mm±10% | 6 mm±10% | 12 mm±10% | 22 mm±10% |
| Setting distance | | 0 to 2.4 mm | 0 to 4.8 mm | 0 to 9.6 mm | 0 to 16.8 mm |
| Differential travel | | 15% max. of sensing distance | | | |
| Detectable object | | Ferrous metals (For non-ferrous metals, refer to the <i>Engineering Data</i> on page 34.) | | | |
| Standard sensing object | | Iron, 9 × 9 × 1 mm | Iron, 18 × 18 × 1 mm | Iron, 36 × 36 × 1 mm | Iron, 66 × 66 × 1 mm |
| Response frequency *1 | | 1,000 Hz | 800 Hz | 500 Hz | 200 Hz |
| Power supply voltage | | 10 to 30 VDC (including 10% ripple (p-p)), Class 2 | | | |
| Current consumption | | 1-output models: 16 mA max. | 1-output models: 16 mA max. 2-output models: 20 mA max. | | |
| Output configuration | | B□ Models: PNP open collector, C□ Models: NPN open collector | | | |
| Operation mode (with sensing object approaching) | | 1-output models (B1, C1): NO (Normally open), 1-output models (B2, C2): NC (Normally closed) | 1-output models (B1, C1): NO (Normally open), 1-output models (B2, C2): NC (Normally closed), 2-output models (B3, C3): NO+NC (Normally open, Normally closed) | | |
| Control output | Load current | 1-output models: 10 to 30 VDC, Class 2, 100 mA max. | 1-output models: 10 to 30 VDC, Class 2, 100 mA max., 2-output models: 10 to 30 VDC, Class 2, 50 mA max. | | |
| | Residual voltage | 1-output models: 2 V max. (Load current: 100 mA, Cable length: 2 m) | 1-output models: 2 V max. (Load current: 100 mA, Cable length: 2 m), 2-output models: 2 V max. (Load current: 50 mA, Cable length: 2 m) | | |
| Indicator *2 | | In the Standard I/O mode (SIO mode): Operation indicator (orange, lit) and communication indicator (green, not lit) In the IO-Link communication mode (COM mode): Operation indicator (orange, lit) and communication indicator (green, blinking at 1 s intervals) | | | |
| Protection circuits | | Power supply reverse polarity protection, Surge suppressor, Output short-circuit protection, Output reverse polarity protection | | | |
| Ambient temperature range | | Operating/Storage: -25 to 70°C (with no icing or condensation) | | | |
| Ambient humidity range | | Operating/Storage: 35% to 95% (with no condensation) | | | |
| Temperature influence | | ±10% max. of sensing distance at 23°C in the temperature range of -25 to 70°C | | | |
| Voltage influence | | ±1% max. of sensing distance at rated voltage in the rated voltage ±15% range | | | |
| Insulation resistance | | 50 MΩ min. (at 500 VDC) between current-carrying parts and case | | | |
| Dielectric strength | | 1,000 VAC, 50/60 Hz for 1 minute between current-carrying parts and case | | | |
| Vibration resistance (destruction) | | 10 to 55 Hz, 1.5-mm double amplitude for 2 hours each in X, Y, and Z directions | | | |
| Shock resistance (destruction) | | 500 m/s ² 10 times each in X, Y, and Z directions | 1,000 m/s ² 10 times each in X, Y, and Z directions | | |
| Degree of protection | | Pre-wired Models, Pre-wired Connector Models: IEC 60529: IP67, JIS C 0920 Annex 1: IP67G Connector Models: IEC 60529: IP67 | | | |
| Connection method | | Pre-wired Models (Standard cable length: 2 m) and Pre-wired Connector Models (Standard cable length: 0.3 m), M12 Connector Models | | | |
| Weight *3 (packed state) | Pre-wired Models | Approx. 85 g | Approx. 95 g | Approx. 180 g | Approx. 260 g |
| | M12 Pre-wired Smartclick Connector | Approx. 55 g | Approx. 70 g | Approx. 115 g | Approx. 200 g |
| | Connector | Approx. 40 g | Approx. 55 g | Approx. 95 g | Approx. 180 g |
| Materials | Case | Fluororesin coating (Base material: brass) | | | |
| | Sensing surface | Fluorine resin | | | |
| | Clamping nuts | Fluororesin coating (Base material: brass) | | | |
| | Toothed washers | Zinc-plated iron | | | |
| | Cable | Vinyl chloride (PVC) | | | |
| Main IO-Link functions *2 | | Operation mode switching between NO and NC, sensor internals failure alert, excessive target proximity alarm selection, control output timer function selection (ON delay, OFF delay, One shot options), instability detection alarm with ON delay timer selection, monitor output strength, operating hours read-out, readout of the sensor internal temperature, and factory reset | | | |
| IO-Link Communication specifications *2 | IO-Link specification | Ver 1.1 | | | |
| | Baud rate | COM2 (38.4 kbps), COM3 (230.4 kbps) | | | |
| | Data length | PD size: 2 bytes, OD size: 1 byte (M-sequence type: TYPE_2_2) | | | |
| | Minimum cycle time | COM2: 2.3 ms, COM3: 0.4 ms | | | |
| Accessories | | Instruction manual, Clamping nuts, Toothed washer | | | |

*1. The response frequency is an average value. Measurement conditions are as follows: standard sensing object, a distance of twice the standard sensing object, and a set distance of half the sensing distance.

*2. IO-Link is not supported for NC-type PNP outputs or all types of NPN outputs.

*3. Weight of the standard body-sized model.

E2E/E2EQ NEXT Series

BASIC Model

E2E NEXT Series (Double/Single distance model) DC 3-wire Shielded

| Item | Types Size Model | Double distance | | | | Single distance | | | |
|--|------------------------------------|---|---|-------------------------|-------------------------|---|---|-------------------------|-------------------------|
| | | M8 | M12 | M18 | M30 | M8 | M12 | M18 | M30 |
| | | E2E-X2□8 | E2E-X4□12 | E2E-X8□18 | E2E-X15□30 | E2E-X1R5□8 | E2E-X2□12 | E2E-X5□18 | E2E-X10□30 |
| Sensing distance | | 2 mm±10% | 4 mm±10% | 8 mm±10% | 15 mm±10% | 1.5 mm±10% | 2 mm±10% | 5 mm±10% | 10 mm±10% |
| Setting distance | | 0 to 1.6 mm | 0 to 3.2 mm | 0 to 6.4 mm | 0 to 12 mm | 0 to 1.2 mm | 0 to 1.6 mm | 0 to 4 mm | 0 to 8 mm |
| Differential travel | | 15% max. of sensing distance | | | | 10% max. of sensing distance | | | |
| Detectable object | | Ferrous metals (For non-ferrous metals, refer to the <i>Engineering Data</i> on page 34.) | | | | | | | |
| Standard sensing object | | Iron, 8 × 8 × 1 mm | Iron, 12 × 12 × 1 mm | Iron, 24 × 24 × 1 mm | Iron, 45 × 45 × 1 mm | Iron, 8 × 8 × 1 mm | Iron, 12 × 12 × 1 mm | Iron, 18 × 18 × 1 mm | Iron, 30 × 30 × 1 mm |
| Response frequency *1 | | 1,500 Hz | 1,000 Hz | 500 Hz | 250 Hz | 2,000 Hz | 1,500 Hz | 600 Hz | 400 Hz |
| Power supply voltage | | 10 to 30 VDC (including 10% ripple (p-p)), Class 2 | | | | | | | |
| Current consumption | | 1-output models: 16 mA max. 2-output models: 20 mA max. | | | | | | | |
| Output configuration | | B□ Models: PNP open collector C□ Models: NPN open collector | | | | | | | |
| Operation mode (with sensing object approaching) | | 1-output models (B1, C1): NO (Normally open), 1-output models (B2, C2): NC (Normally closed), 2-output models (B3, C3): NO+NC (Normally open, Normally closed) *3 | | | | | | | |
| Control output | Load current | 1-output models: 10 to 30 VDC, Class 2, 200 mA max., (-40 to 70°C), 100 mA max., (70 to 85°C) 2-output models: 10 to 30 VDC, Class 2, 50 mA max. | 1-output models: 10 to 30 VDC, Class 2, 200 mA max., 2-output models: 10 to 30 VDC, Class 2, 100 mA max. | | | 1-output models: 10 to 30 VDC, Class 2, 200 mA max., (-40 to 70°C), 100 mA max., (70 to 85°C) 2-output models: 10 to 30 VDC, Class 2, 50 mA max. | 1-output models: 10 to 30 VDC, Class 2, 200 mA max., 2-output models: 10 to 30 VDC, Class 2, 100 mA max. | | |
| | Residual voltage | 1-output models: 2 V max. (Load current: 200 mA, Cable length: 2 m), 2-output models: 2 V max. (Load current: 50 mA, Cable length: 2 m) | 1-output models: 2 V max. (Load current: 200 mA, Cable length: 2 m), 2-output models: 2 V max. (Load current: 100 mA, Cable length: 2 m) | | | 1-output models: 2 V max. (Load current: 200 mA, Cable length: 2 m), 2-output models: 2 V max. (Load current: 50 mA, Cable length: 2 m) | 1-output models: 2 V max. (Load current: 200 mA, Cable length: 2 m), 2-output models: 2 V max. (Load current: 100 mA, Cable length: 2 m) | | |
| Indicator *2 | | In the Standard I/O mode (SIO mode): Operation indicator (orange, lit) and communication indicator (green, not lit) In the IO-Link communication mode (COM mode): Operation indicator (orange, lit) and communication indicator (green, blinking at 1 s intervals) | | | | | | | |
| Protection circuits | | Power supply reverse polarity protection, Surge suppressor, Output short-circuit protection, Output reverse polarity protection | | | | | | | |
| Ambient temperature range | | Operating/Storage: -40 to 85°C (with no icing or condensation) Note: The UL temperature rating for M12 Pre-wired Connector Models is -25 to 70°C. | | | | | | | |
| Ambient humidity range | | Operating/Storage: 35% to 95% (with no condensation) | | | | | | | |
| Temperature influence | | ±15% max. of sensing distance at 23°C in the temperature range of -40 to 85°C ±10% max. of sensing distance at 23°C in the temperature range of -25 to 70°C | | | | | | | |
| Voltage influence | | ±1% max. of sensing distance at rated voltage in the rated voltage ±15% range | | | | | | | |
| Insulation resistance | | 50 MΩ min. (at 500 VDC) between current-carrying parts and case | | | | | | | |
| Dielectric strength | | 1,000 VAC, 50/60 Hz for 1 minute between current-carrying parts and case | | | | | | | |
| Vibration resistance (destruction) | | 10 to 55 Hz, 1.5-mm double amplitude for 2 hours each in X, Y, and Z directions | | | | | | | |
| Shock resistance (destruction) | | 500 m/s ² 10 times each in X, Y, and Z directions | 1,000 m/s ² 10 times each in X, Y, and Z directions | | | 500 m/s ² 10 times each in X, Y, and Z directions | 1,000 m/s ² 10 times each in X, Y, and Z directions | | |
| Degree of protection | | Pre-wired Models, Pre-wired Connector Models: IEC 60529:IP67, ISO 20653 (old standard: DIN 40050 PART9): IP69K, JIS C 0920 Annex 1: IP67G, Passed OMRON's Oil-resistant Component Evaluation Standards *4 (Cutting oil type: specified in JIS K 2241:2000; Temperature: 35°C max.) Connector Models: IEC 60529: IP67, ISO 20653 (old standard: DIN 40050 PART9): IP69K | | | | | | | |
| Connection method | | Pre-wired Models (Standard cable length: 2 m), Pre-wired Connector Models (Standard cable length: 0.3 m) and Connector Models (M12 Connector, M8 (4-pin) Connector and M8 (3-pin) Connector) | | | | | | | |
| Weight *5 (packed state) | Pre-wired | Approx. 85 g | Approx. 95 g | Approx. 170 g | Approx. 240 g | Approx. 85 g | Approx. 95 g | Approx. 170 g | Approx. 240 g |
| | M12 Pre-wired Smartclick Connector | Approx. 55 g | Approx. 70 g | Approx. 105 g | Approx. 170 g | Approx. 55 g | Approx. 70 g | Approx. 105 g | Approx. 170 g |
| | Connector | Approx. 40 g *6 | Approx. 55 g | Approx. 85 g | Approx. 160 g | Approx. 40 g *6 | Approx. 55 g | Approx. 85 g | Approx. 160 g |

| Item | Types Size Model | Double distance | | | | Single distance | | | |
|---|------------------------|--|---------------------|-----------|------------|--------------------|---------------------|-----------|------------|
| | | M8 | M12 | M18 | M30 | M8 | M12 | M18 | M30 |
| | | E2E-X2□8 | E2E-X4□12 | E2E-X8□18 | E2E-X15□30 | E2E-X1R5□8 | E2E-X2□12 | E2E-X5□18 | E2E-X10□30 |
| Materials | Case | Stainless (SUS303) | Nickel-plated brass | | | Stainless (SUS303) | Nickel-plated brass | | |
| | Sensing surface | Polybutylene terephthalat (PBT) | | | | | | | |
| | Clamping nuts | Nickel-plated brass | | | | | | | |
| | Toothed washers | Zinc-plated iron | | | | | | | |
| | Cable | Vinyl chloride (PVC) | | | | | | | |
| Main IO-Link functions *2 | | Operation mode switching between NO and NC, sensor internals failure alert, excessive target proximity alarm selection, control output timer function selection (ON delay, OFF delay, One shot options), instability detection alarm with ON delay timer selection, monitor output strength, operating hours read-out, readout of the sensor internal temperature, and factory reset | | | | | | | |
| IO-Link Communication specifications *2 | IO-Link specification | Ver1.1 | | | | | | | |
| | Baud rate | COM2 (38.4 kbps), COM3 (230.4 kbps) | | | | | | | |
| | Data length | PD size: 2 bytes, OD size: 1 byte (M-sequence type: TYPE_2_2) | | | | | | | |
| | Minimum cycle time | COM2: 2.3 ms, COM3: 0.4 ms | | | | | | | |
| Accessories | | Instruction manual, Clamping nuts, Toothed washer | | | | | | | |

*1. The response frequency is an average value. Measurement conditions are as follows: standard sensing object, a distance of twice the standard sensing object, and a set distance of half the sensing distance.

*2. IO-Link is not supported for NC-type PNP outputs or all types of NPN outputs.

*3. Dual-output specification for the M8-size models is only applicable to long-size M12 Connector models.

*4. The Oil-resistant Component Evaluation Standards are OMRON's own durability evaluation standards. 2-year oil resistance indicates the median value of the product design and the oil-resistance performance criterion result (=Typical value). Actual performance can be expected to decline after two years on average from shipment. The Pre-wired Connector Model verifies 2 years of oil resistance when mating with Round Oil-resistant Connectors XS5 NEXT series correctly. The degree of protection is not satisfied with the part where cable wires are uncovered for the Pre-wired Models.

*5. Weight of the standard body-sized model.

*6. Both M8 connectors and M12 connectors are available.

E2E/E2EQ NEXT Series

BASIC Model

E2E NEXT Series (Double/Single distance model)

DC 3-wire

Unshielded

| Item | Types Size Model | Double distance model | | | | Single distance model | | | |
|--|------------------------------------|--|---|-------------------------|-------------------------|---|---|-------------------------|-------------------------|
| | | M8 | M12 | M18 | M30 | M8 | M12 | M18 | M30 |
| | | E2E-X4M□8 | E2E-X8M□12 | E2E-X16M□18 | E2E-X30M□30 | E2E-X2M□8 | E2E-X5M□12 | E2E-X10M□18 | E2E-X18M□30 |
| Sensing distance | | 4 mm±10% | 8 mm±10% | 16 mm±10% | 30 mm±10% | 2 mm±10% | 5 mm±10% | 10 mm±10% | 18 mm±10% |
| Setting distance | | 0 to 3.2 mm | 0 to 6.4 mm | 0 to 12.8 mm | 0 to 24 mm | 0 to 1.6 mm | 0 to 4 mm | 0 to 8 mm | 0 to 14.4 mm |
| Differential travel | | 15% max. of sensing distance | | | | 10% max. of sensing distance | | | |
| Detectable object | | Ferrous metals (For non-ferrous metals, refer to the <i>Engineering Data</i> on page 34.) | | | | | | | |
| Standard sensing object | | Iron, 12 × 12 × 1 mm | Iron, 24 × 24 × 1 mm | Iron, 48 × 48 × 1 mm | Iron, 90 × 90 × 1 mm | Iron, 8 × 8 × 1 mm | Iron, 15 × 15 × 1 mm | Iron, 30 × 30 × 1 mm | Iron, 54 × 54 × 1 mm |
| Response frequency *1 | | 1,000 Hz | 800 Hz | 400 Hz | 100 Hz | 1,000 Hz | 800 Hz | 400 Hz | 100 Hz |
| Power supply voltage | | 10 to 30 VDC (including 10% ripple (p-p)), Class 2 | | | | | | | |
| Current consumption | | 1-output models: 16 mA max. 2-output models: 20 mA max. | | | | | | | |
| Output configuration | | B□ Models: PNP open collector C□ Models: NPN open collector | | | | | | | |
| Operation mode (with sensing object approaching) | | 1-output models (B1, C1): NO (Normally open), 1-output models (B2, C3): NC (Normally closed) 2-output models (B3, C3): NO+NC (Normally open, Normally closed) *3 | | | | | | | |
| Control output | Load current | 1-output models: 10 to 30 VDC, Class 2, 200 mA max., (-40 to 70°C), 100 mA max., (70 to 85°C) 2-output models: 10 to 30 VDC, Class 2, 50 mA max. | 1-output models: 10 to 30 VDC, Class 2, 200 mA max., 2-output models: 10 to 30 VDC, Class 2, 100 mA max. | | | 1-output models: 10 to 30 VDC, Class 2, 200 mA max., (-40 to 70°C), 100 mA max., (70 to 85°C) 2-output models: 10 to 30 VDC, Class 2, 50 mA max. | 1-output models: 10 to 30 VDC, Class 2, 200 mA max., 2-output models: 10 to 30 VDC, Class 2, 100 mA max. | | |
| | Residual voltage | 1-output models: 2 V max. (Load current: 200 mA, Cable length: 2 m), 2-output models: 2 V max. (Load current: 50 mA, Cable length: 2 m) | 1-output models: 2 V max. (Load current: 200 mA, Cable length: 2 m), 2-output models: 2 V max. (Load current: 100 mA, Cable length: 2 m) | | | 1-output models: 2 V max. (Load current: 200 mA, Cable length: 2 m), 2-output models: 2 V max. (Load current: 50 mA, Cable length: 2 m) | 1-output models: 2 V max. (under load current of 200 mA with cable length of 2 m), 2-output models: 2 V max. (under load current of 100 mA with cable length of 2 m) | | |
| Indicator *2 | | In the Standard I/O mode (SIO mode): Operation indicator (orange, lit) and communication indicator (green, not lit) In the IO-Link communication mode (COM mode): Operation indicator (orange, lit) and communication indicator (green, blinking at 1 s intervals) | | | | | | | |
| Protection circuits | | Power supply reverse polarity protection, Surge suppressor, Output short-circuit protection, Output reverse polarity protection | | | | | | | |
| Ambient temperature range | | Operating/Storage: -40 to 85°C (with no icing or condensation) Note: The UL temperature rating for M12 Pre-wired Connector Models is -25 to 70°C. | | | | | | | |
| Ambient humidity range | | Operating/Storage: 35% to 95% (with no condensation) | | | | | | | |
| Temperature influence | | ±15% max. of sensing distance at 23°C in the temperature range of -40 to 85°C ±10% max. of sensing distance at 23°C in the temperature range of -25 to 70°C | | | | | | | |
| Voltage influence | | ±1% max. of sensing distance at rated voltage in the rated voltage ±15% range | | | | | | | |
| Insulation resistance | | 50 MΩ min. (at 500 VDC) between current-carrying parts and case | | | | | | | |
| Dielectric strength | | 1,000 VAC, 50/60 Hz for 1 minute between current-carrying parts and case | | | | | | | |
| Vibration resistance (destruction) | | 10 to 55 Hz, 1.5-mm double amplitude for 2 hours each in X, Y, and Z directions | | | | | | | |
| Shock resistance (destruction) | | 500 m/s ² 10 times each in X, Y, and Z directions | 1,000 m/s ² 10 times each in X, Y, and Z directions | | | 500 m/s ² 10 times each in X, Y, and Z directions | 1,000 m/s ² 10 times each in X, Y, and Z directions | | |
| Degree of protection | | Pre-wired Models, Pre-wired Connector Models: IEC 60529:IP67, ISO 20653 (old standard: DIN 40050 PART9): IP69K, JIS C 0920 Annex 1: IP67G, Passed OMRON's Oil-resistant Component Evaluation Standards *4 (Cutting oil type: specified in JIS K 2241:2000; Temperature: 35°C max.) Connector Models: IEC 60529:IP67, ISO 20653 (old standard: DIN 40050 PART9): IP69K | | | | | | | |
| Connection method | | Pre-wired Models (Standard cable length: 2 m), Pre-wired Connector Models (Standard cable length: 0.3 m) and Models (M12 Connector, M8 (4-pin) Connector and M8 (3-pin) Connector) | | | | | | | |
| Weight *5 (packed state) | Pre-wired | Approx. 85 g | Approx. 95 g | Approx. 170 g | Approx. 280 g | Approx. 85 g | Approx. 95 g | Approx. 170 g | Approx. 240 g |
| | M12 Pre-wired Smartclick Connector | Approx. 55 g | Approx. 70 g | Approx. 105 g | Approx. 220 g | Approx. 55 g | Approx. 70 g | Approx. 105 g | Approx. 170 g |
| | Connector | Approx. 40 g *6 | Approx. 55 g | Approx. 85 g | Approx. 200 g | Approx. 40 g *6 | Approx. 55 g | Approx. 85 g | Approx. 160 g |

| Item | Types Size Model | Double distance model | | | | Single distance model | | | |
|---|------------------------|--|---------------------|-------------|-------------|-----------------------|---------------------|-------------|-------------|
| | | M8 | M12 | M18 | M30 | M8 | M12 | M18 | M30 |
| | | E2E-X4M□8 | E2E-X8M□12 | E2E-X16M□18 | E2E-X30M□30 | E2E-X2M□8 | E2E-X5M□12 | E2E-X10M□18 | E2E-X18M□30 |
| Materials | Case | Stainless (SUS303) | Nickel-plated brass | | | Stainless (SUS303) | Nickel-plated brass | | |
| | Sensing surface | Polybutylene terephthalat (PBT) | | | | | | | |
| | Clamping nuts | Nickel-plated brass | | | | | | | |
| | Toothed washers | Zinc-plated iron | | | | | | | |
| | Cable | Vinyl chloride (PVC) | | | | | | | |
| Main IO-Link functions *2 | | Operation mode switching between NO and NC, sensor internals failure alert, excessive target proximity alarm selection, control output timer function selection (ON delay, OFF delay, One shot options), instability detection alarm with ON delay timer selection, monitor output strength, operating hours read-out, readout of the sensor internal temperature, and factory reset | | | | | | | |
| IO-Link Communication specifications *2 | IO-Link specification | Ver 1.1 | | | | | | | |
| | Baud rate | COM2 (38.4 kbps), COM3 (230.4 kbps) | | | | | | | |
| | Data length | PD size: 2 bytes, OD size: 1 byte (M-sequence type: TYPE_2_2) | | | | | | | |
| | Minimum cycle time | COM2: 2.3 ms, COM3: 0.4 ms | | | | | | | |
| Accessories | | Instruction manual, Clamping nuts, Toothed washer | | | | | | | |

*1. The response frequency is an average value. Measurement conditions are as follows: standard sensing object, a distance of twice the standard sensing object, and a set distance of half the sensing distance.

*2. IO-Link is not supported for NC-type PNP outputs or all types of NPN outputs.

*3. Dual-output specification for the M8-size models is only applicable to long-size M12 Connector models.

*4. The Oil-resistant Component Evaluation Standards are OMRON's own durability evaluation standards. 2-year oil resistance indicates the median value of the product design and the oil-resistance performance criterion result (=Typical value). Actual performance can be expected to decline after two years on average from shipment. The Pre-wired Connector Model verifies 2 years of oil resistance when mating with Round Oil-resistant Connectors XS5 NEXT series correctly. The degree of protection is not satisfied with the part where cable wires are uncovered for the Pre-wired Models.

*5. Weight of the standard body-sized model.

*6. Both M8 connectors and M12 connectors are available.

E2E/E2EQ NEXT Series

BASIC Model

E2E Q NEXT Series (Spatter-resistant Double distance/Single distance model) DC 3-Wire Models Shielded

| Item | Types Size Model | Double distance | | | | Single distance | | | | |
|---|---|---|---|-------------------------|-------------------------|---|---|---|-------------------------|--|
| | | M8 | M12 | M18 | M30 | M8 | M12 | M18 | M30 | |
| | | E2EQ-X2□8 | E2EQ-X4□12 | E2EQ-X8□18 | E2EQ-X15□30 | E2EQ-X1R5□8 | E2EQ-X2□12 | E2EQ-X5□18 | E2EQ-X10□30 | |
| Sensing distance | | 2 mm±10% | 4 mm±10% | 8 mm±10% | 15 mm±10% | 1.5 mm±10% | 2 mm±10% | 5 mm±10% | 10 mm±10% | |
| Setting distance | | 0 to 1.6 mm | 0 to 3.2 mm | 0 to 6.4 mm | 0 to 12 mm | 0 to 1.2 mm | 0 to 1.6 mm | 0 to 4 mm | 0 to 8 mm | |
| Differential travel | | 15% max. of sensing distance | | | | 10% max. of sensing distance | | | | |
| Detectable object | | Ferrous metals (For non-ferrous metals, refer to the <i>Engineering Data</i> on page 34.) | | | | | | | | |
| Standard sensing object | | Iron, 8 × 8 × 1 mm | Iron, 12 × 12 × 1 mm | Iron, 24 × 24 × 1 mm | Iron, 45 × 45 × 1 mm | Iron, 8 × 8 × 1 mm | Iron, 12 × 12 × 1 mm | Iron, 18 × 18 × 1 mm | Iron, 30 × 30 × 1 mm | |
| Response frequency *1 | | 1,500 Hz | 1,000 Hz | 500 Hz | 250 Hz | 2,000 Hz | 1,500 Hz | 600 Hz | 400 Hz | |
| Power supply voltage | | 10 to 30 VDC (including 10% ripple (p-p)), Class 2 | | | | | | | | |
| Current consumption | | 1-output models: 16 mA max. 2-output models: 20 mA max. | | | | | | | | |
| Output configuration | | B□ Models: PNP open collector, C□ Models: NPN open collector | | | | | | | | |
| Operation mode (with sensing object approaching) | | 1-output models (B1, C1): NO (Normally open), 1-output models (B2, C2): NC (Normally closed) 2-output models (B3, C3): NO+NC (Normally open, Normally closed) | | | | | | | | |
| Control output | Load current | 1-output models: 10 to 30 VDC, Class 2, 200 mA max., (-40 to 70°C), 100 mA max., (70 to 85°C) 2-output models: 10 to 30 VDC, Class 2, 50 mA max. | 1-output models: 10 to 30 VDC, Class 2, 200 mA max., 2-output models: 10 to 30 VDC, Class 2, 100 mA max. | | | 1-output models: 10 to 30 VDC, Class 2, 200 mA max., (-40 to 70°C), 100 mA max., (70 to 85°C) 2-output models: 10 to 30 VDC, Class 2, 50 mA max. | | 1-output models: 10 to 30 VDC, Class 2, 200 mA max., 2-output models: 10 to 30 VDC, Class 2, 100 mA max. | | |
| | Residual voltage | 1-output models: 2 V max. (Load current: 200 mA, Cable length: 2 m), 2-output models: 2 V max. (Load current: 50 mA, Cable length: 2 m) | 1-output models: 2 V max. (Load current: 200 mA, Cable length: 2 m), 2-output models: 2 V max. (Load current: 100 mA, Cable length: 2 m) | | | 1-output models: 2 V max. (Load current: 200 mA, Cable length: 2 m), 2-output models: 2 V max. (Load current: 50 mA, Cable length: 2 m) | | 1-output models: 2 V max. (Load current: 200 mA, Cable length: 2 m), 2-output models: 2 V max. (Load current: 100 mA, Cable length: 2 m) | | |
| Indicator *2 | | In the Standard I/O mode (SIO mode): Operation indicator (orange, lit) and communication indicator (green, not lit) In the IO-Link communication mode (COM mode): Operation indicator (orange, lit) and communication indicator (green, blinking at 1 s intervals) | | | | | | | | |
| Protection circuits | | Power supply reverse polarity protection, Surge suppressor, Output short-circuit protection, Output reverse polarity protection | | | | | | | | |
| Ambient temperature range | | Operating/Storage: -40 to 85°C (with no icing or condensation) Note: The UL temperature rating for M12 Pre-wired Connector Models is -25 to 70°C. | | | | | | | | |
| Ambient humidity range | | Operating/Storage: 35% to 95% (with no condensation) | | | | | | | | |
| Temperature influence | | ±15% max. of sensing distance at 23°C in the temperature range of -40 to 85°C ±10% max. of sensing distance at 23°C in the temperature range of -25 to 70°C | | | | | | | | |
| Voltage influence | | ±1% max. of sensing distance at rated voltage in the rated voltage ±15% range | | | | | | | | |
| Insulation resistance | | 50 MΩ min. (at 500 VDC) between current-carrying parts and case | | | | | | | | |
| Dielectric strength | | 1,000 VAC, 50/60 Hz for 1 minute between current-carrying parts and case | | | | | | | | |
| Vibration resistance (destruction) | | 10 to 55 Hz, 1.5-mm double amplitude for 2 hours each in X, Y, and Z directions | | | | | | | | |
| Shock resistance (destruction) | | 500 m/s ² 10 times each in X, Y, and Z directions | 1,000 m/s ² 10 times each in X, Y, and Z directions | | | 500 m/s ² 10 times each in X, Y, and Z directions | 1,000 m/s ² 10 times each in X, Y, and Z directions | | | |
| Degree of protection | | Pre-wired Models, Pre-wired Connector Models: IEC 60529:IP67, JIS C 0920 Annex 1: IP67G Connector Models: IEC 60529 IP67 | | | | | | | | |
| Connection method | | Pre-wired Models (Standard cable length: 2 m) and Pre-wired Connector Models (Standard cable length: 0.3 m), M12 Connector Models | | | | | | | | |
| Weight *3 (packed state) | Pre-wired | Approx. 85 g | Approx. 95 g | Approx. 170 g | Approx. 240 g | Approx. 85 g | Approx. 95 g | Approx. 170 g | Approx. 240 g | |
| | M12 Pre-wired Smartclick Connector | Approx. 55 g | Approx. 70 g | Approx. 105 g | Approx. 170 g | Approx. 55 g | Approx. 70 g | Approx. 105 g | Approx. 170 g | |
| | Connector | Approx. 40 g | Approx. 55 g | Approx. 85 g | Approx. 160 g | Approx. 40 g | Approx. 55 g | Approx. 85 g | Approx. 160 g | |

| Item | Types Size Model | Double distance | | | | Single distance | | | |
|---|------------------------|--|--|-------------|---|--|------------|------------|-------------|
| | | M8 | M12 | M18 | M30 | M8 | M12 | M18 | M30 |
| | | E2EQ-X2□8 | E2EQ-X4□12 | E2EQ-X8□□18 | E2EQ-X15□30 | E2EQ-X1R5□8 | E2EQ-X2□12 | E2EQ-X5□18 | E2EQ-X10□30 |
| Materials | Case | Fluororesin coating (Base material: SUS303) | Fluororesin coating (Base material: brass) | | Fluororesin coating (Base material: SUS303) | Fluororesin coating (Base material: brass) | | | |
| | Sensing surface | Fluorine resin | | | | | | | |
| | Clamping nuts | Fluororesin coating (Base material: brass) | | | | | | | |
| | Toothed washers | Zinc-plated iron | | | | | | | |
| | Cable | Vinyl chloride (PVC) | | | | | | | |
| Main IO-Link functions *2 | | Operation mode switching between NO and NC, sensor internals failure alert, excessive target proximity alarm selection, control output timer function selection (ON delay, OFF delay, One shot options), instability detection alarm with ON delay timer selection, monitor output strength, operating hours read-out, readout of the sensor internal temperature, and factory reset | | | | | | | |
| IO-Link Communication specifications *2 | IO-Link specification | Ver1.1 | | | | | | | |
| | Baud rate | COM2 (38.4 kbps), COM3 (230.4 kbps) | | | | | | | |
| | Data length | PD size: 2 bytes, OD size: 1 byte (M-sequence type: TYPE_2_2) | | | | | | | |
| | Minimum cycle time | COM2: 2.3 ms, COM3: 0.4 ms | | | | | | | |
| Accessories | | Instruction manual, Clamping nuts, Toothed washer | | | | | | | |

*1. The response frequency is an average value. Measurement conditions are as follows: standard sensing object, a distance of twice the standard sensing object, and a set distance of half the sensing distance.

*2. IO-Link is not supported for NC-type PNP outputs or all types of NPN outputs.

*3. Weight of the standard body-sized model.

E2E/E2EQ NEXT Series

Engineering Data (Reference Value)

Sensing Area

PREMIUM Model

Quadruple distance model

Shielded

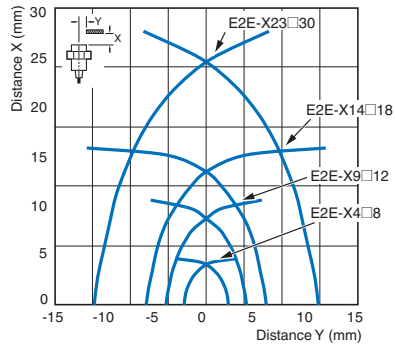

Unshielded

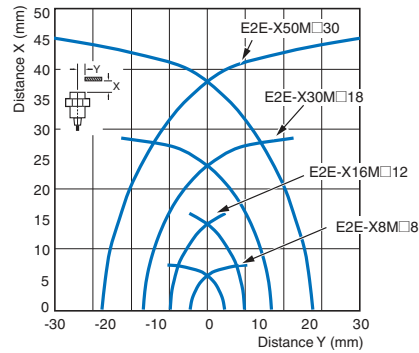

Triple distance model, Spatter-resistant Triple distance model

Shielded

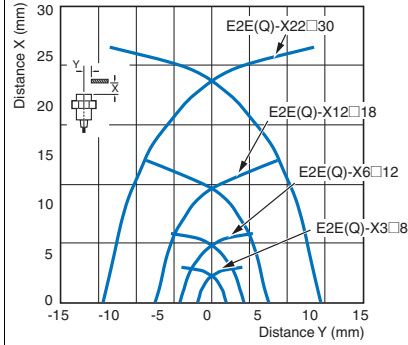

Unshielded

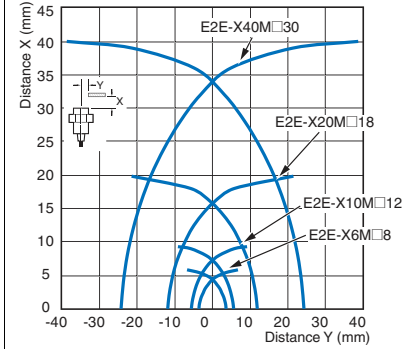

BASIC Model

Double distance model, Spatter-resistant Double distance model

Shielded

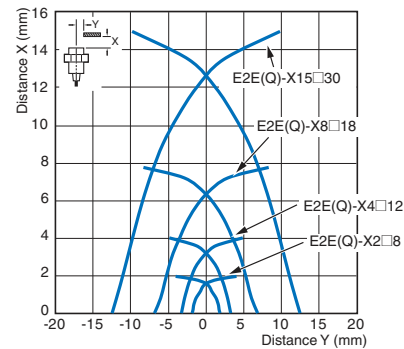

Unshielded

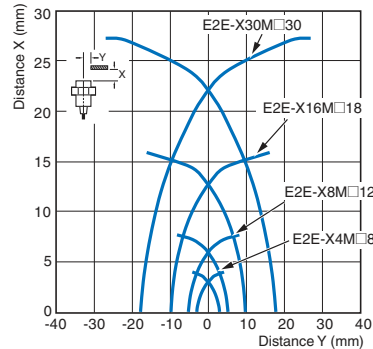

Single distance model, Spatter-resistant Single distance model

Shielded

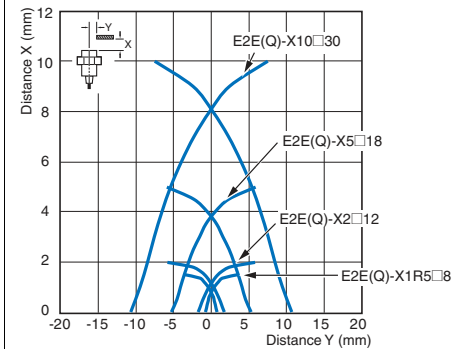

Unshielded

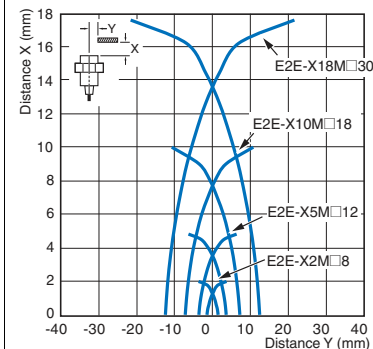

Influence of Sensing Object Size and Material

PREMIUM Model

Shielded

Quadruple distance model

Size: M8 E2E-X4□8

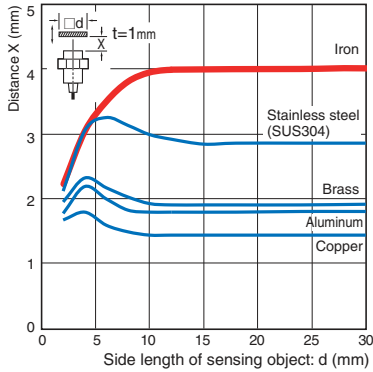

Size: M12 E2E-X9□12

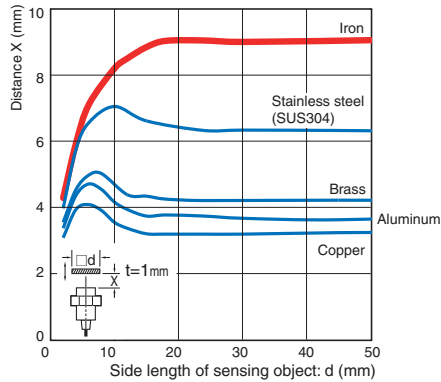

Size: M18 E2E-X14□18

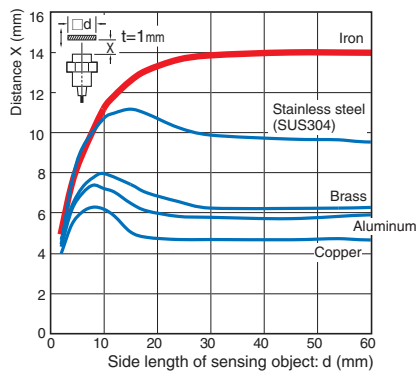

Size: M30 E2E-X23□30

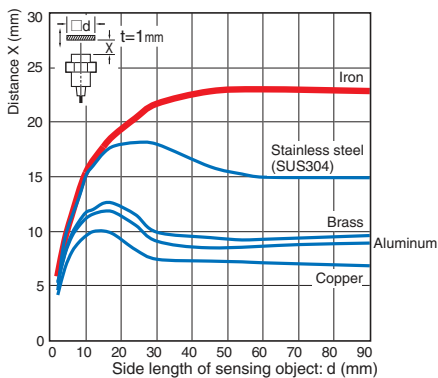

Triple distance model, Spatter-resistant Triple distance model

Size: M8 E2E(Q)-X3□8

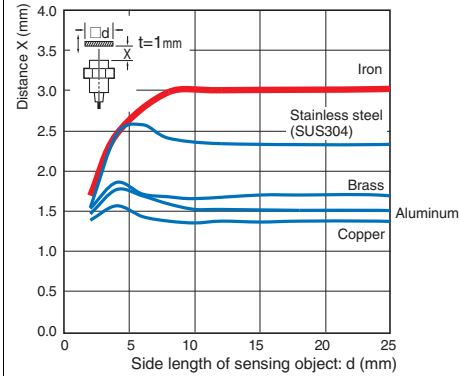

Size: M12 E2E(Q)-X6□12

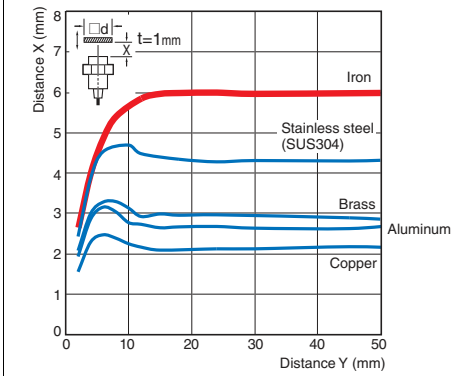

Size: M18 E2E(Q)-X12□18

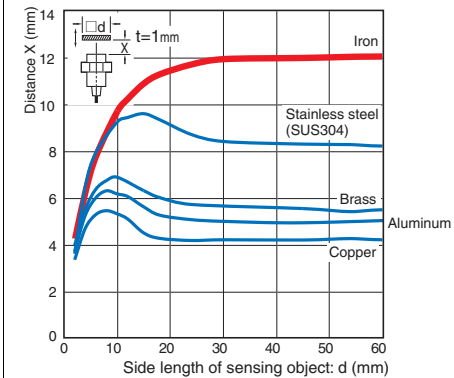

Size: M30 E2E(Q)-X22□30

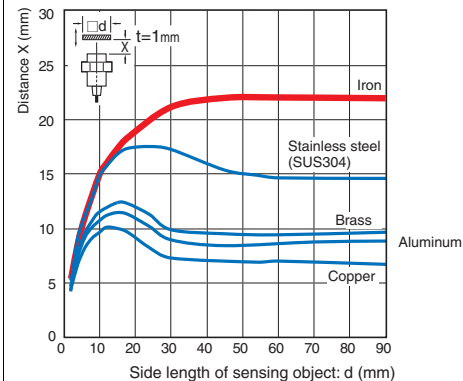

PREMIUM Model

Unshielded

Quadruple distance model

Size: M8 E2E-X8M□8

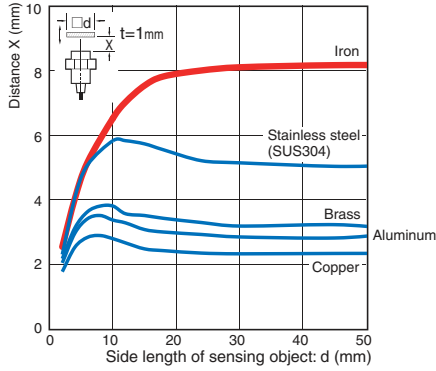

Size: M12 E2E-X16M□12

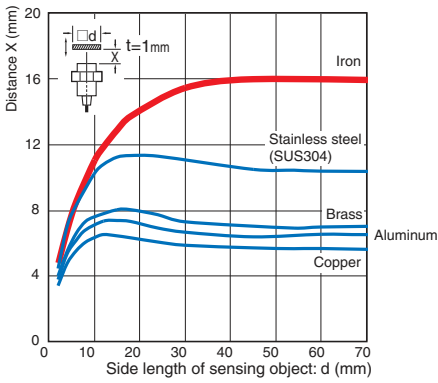

Size: M18 E2E-X30M□18

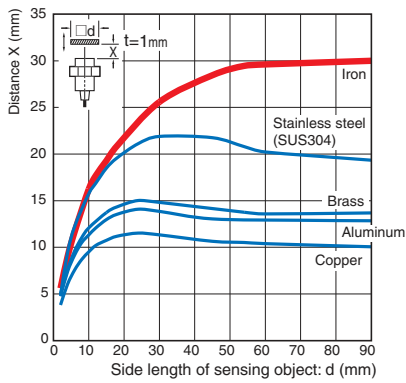

Size: M30 E2E-X50M□30

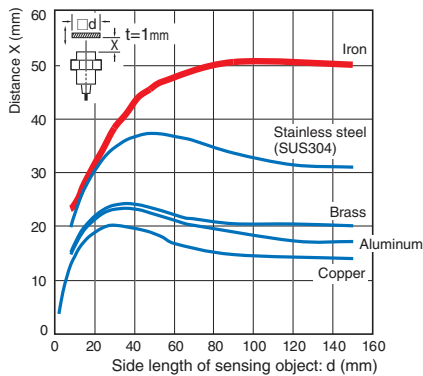

Triple distance model

Size: M8 E2E-X6M□8

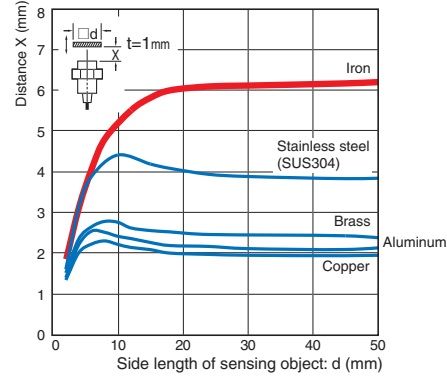

Size: M12 E2E-X10M□12

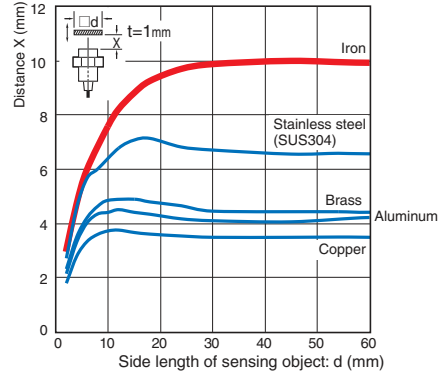

Size: M18 E2E-X20M□18

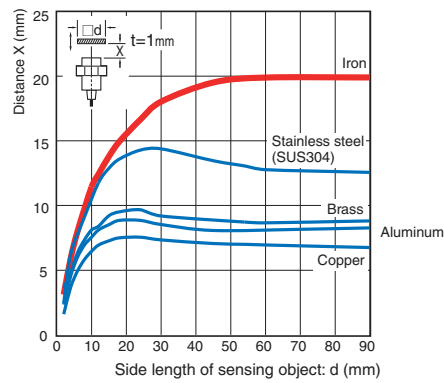

Size: M30 E2E-X40M□30

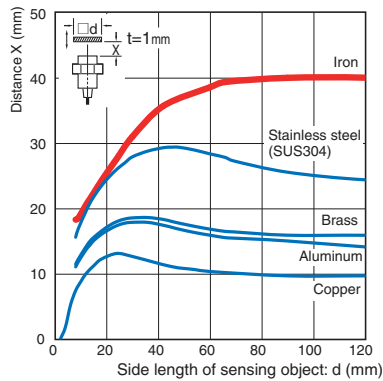

BASIC Model

Shielded

Double distance model, Spatter-resistant Double distance model

Size: M8 E2E(Q)-X2□8

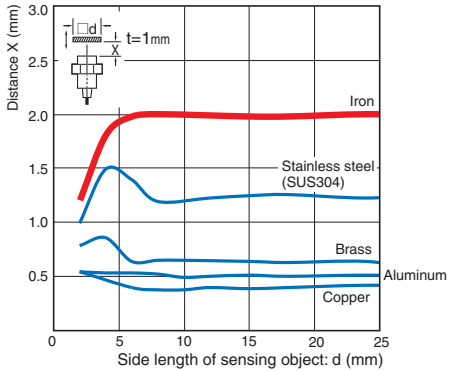

Size: M12 E2E(Q)-X4□12

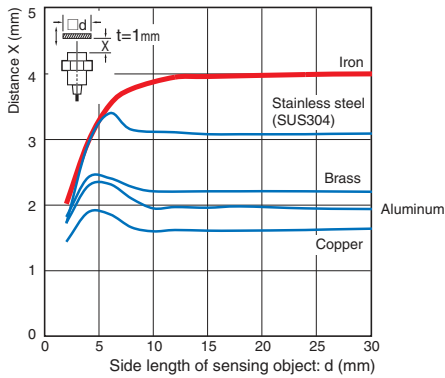

Size: M18 E2E(Q)-X8□18

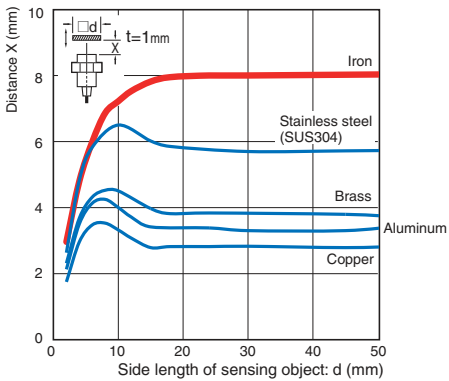

Size: M30 E2E(Q)-X15□30

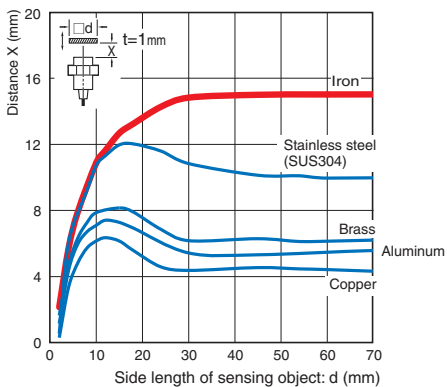

Single distance model, Spatter-resistant Single distance model

Size: M8 E2E(Q)-X1R5□8

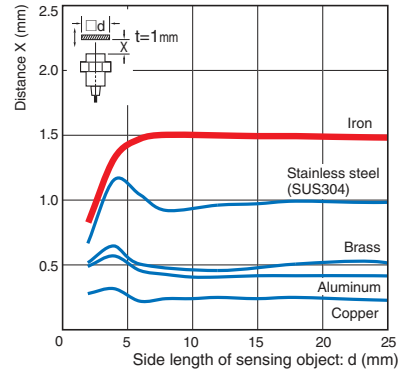

Size: M12 E2E(Q)-X2□12

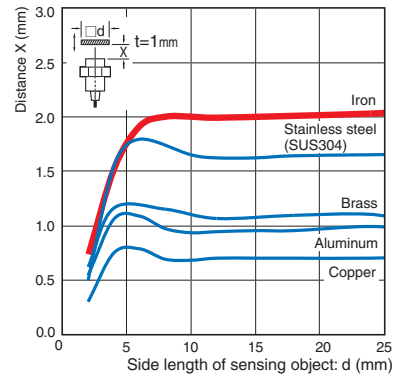

Size: M18 E2E(Q)-X5□18

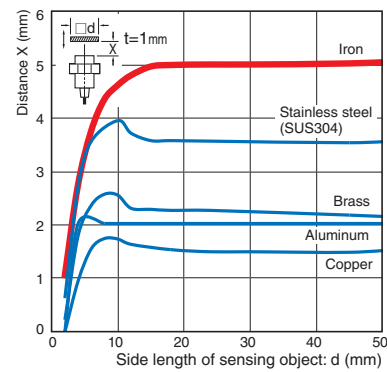

Size: M30 E2E(Q)-X10□30

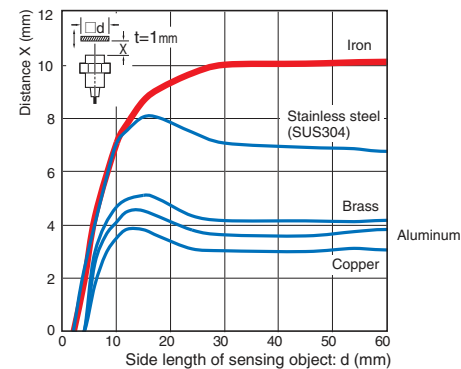

BASIC Model

Unshielded

Double distance model

Size: M8 E2E-X4M□8

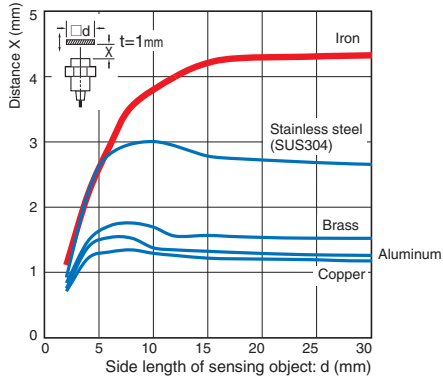

Size: M12 E2E-X8M□12

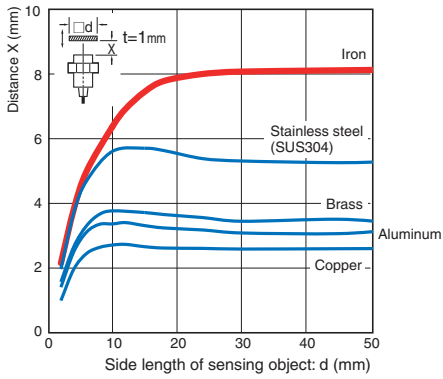

Size: M18 E2E-X16M□18

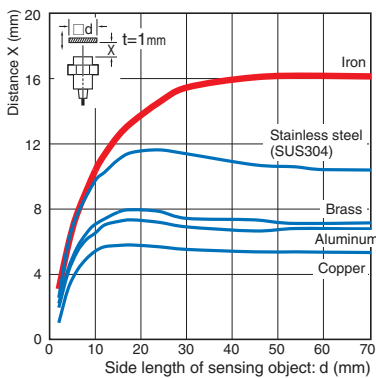

Size: M30 E2E-X30M□30

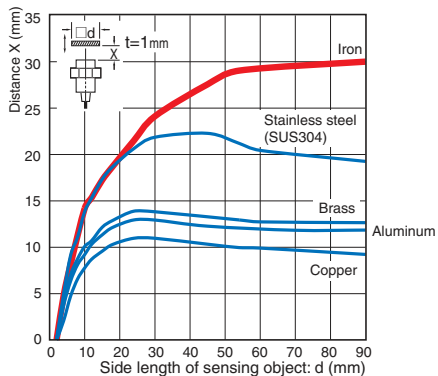

Single distance model

Size: M8 E2E-X2M□8

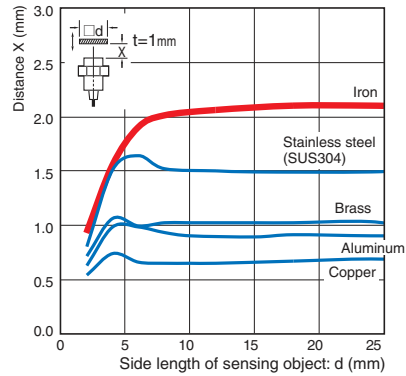

Size: M12 E2E-X5M□12

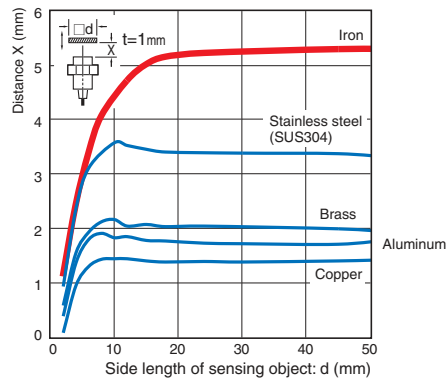

Size: M18 E2E-X10M□18

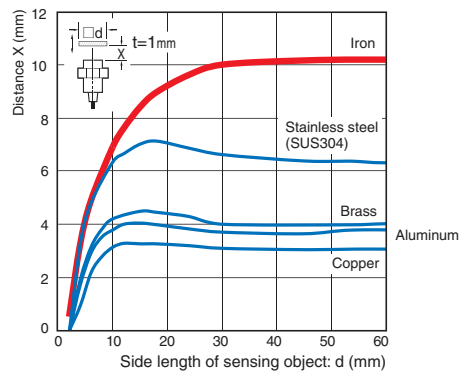

Size: M30 E2E-X18M□30

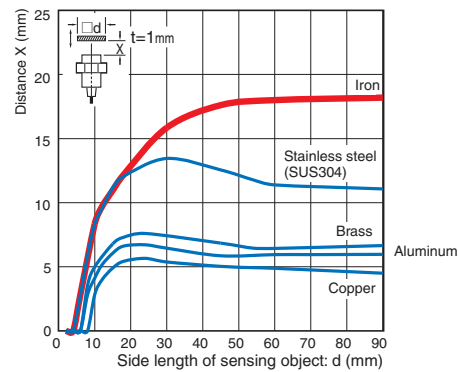

Monitor Output vs. Sensing Distance

PREMIUM Model

Shielded

Quadruple distance model

Size: M8 E2E-X4□8

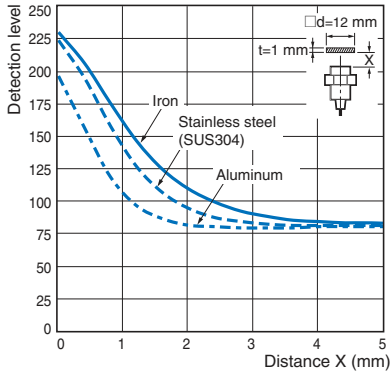

Size: M12 E2E-X9□12

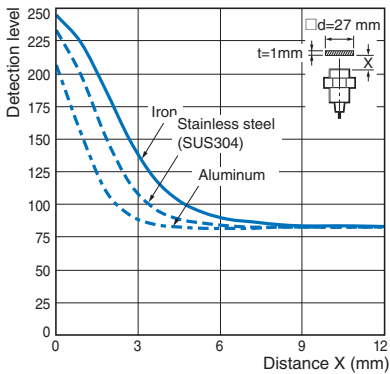

Size: M18 E2E-X14□18

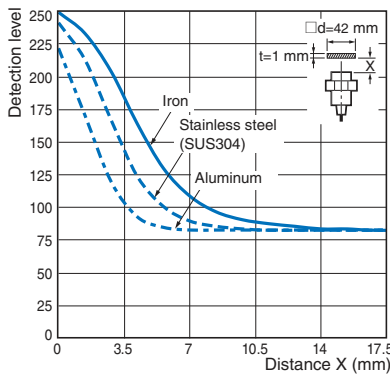

Size: M30 E2E-X23□30

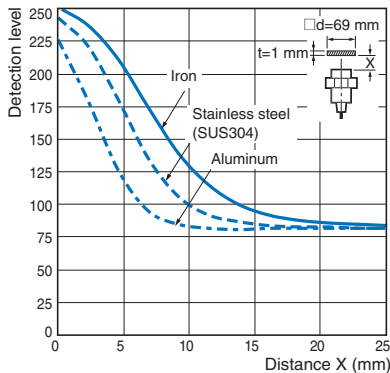

Triple model, Spatter-resistant Triple distance model

Size: M8 E2E(Q)-X3□8

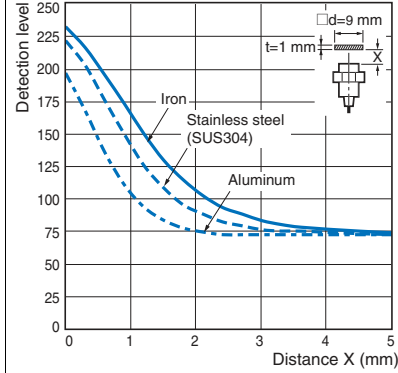

Size: M12 E2E(Q)-X6□12

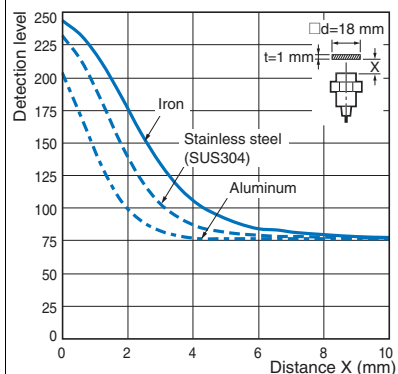

Size: M18 E2E(Q)-X12□18

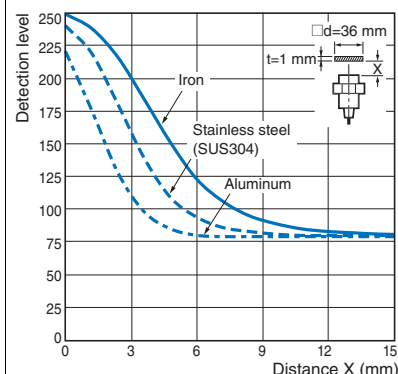

Size: M30 E2E(Q)-X22□30

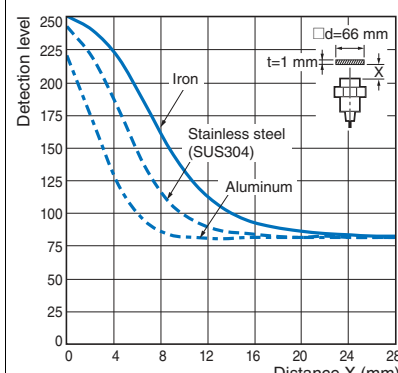

PREMIUM Model

Unshielded

Quadruple distance model

Size: M8 E2E-X8M□8

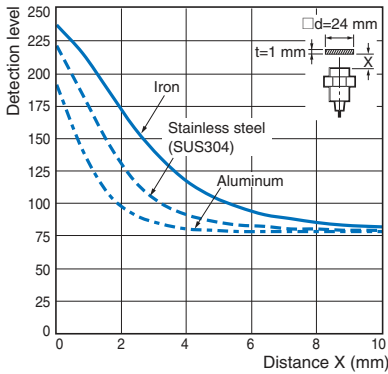

Size: M12 E2E-X16M□12

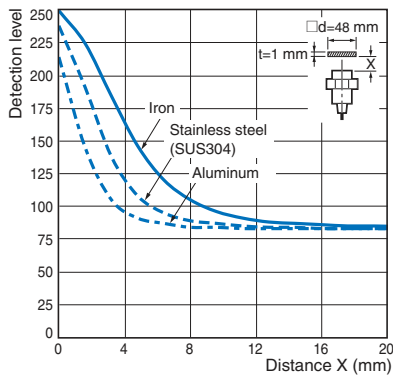

Size: M18 E2E-X30M□18

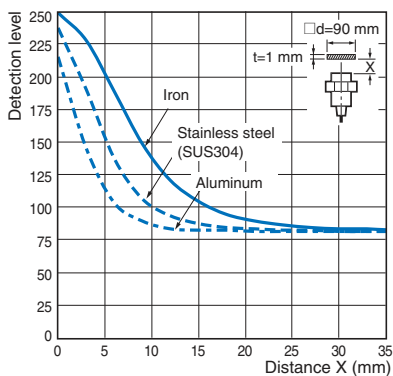

Size: M30 E2E-X50M□30

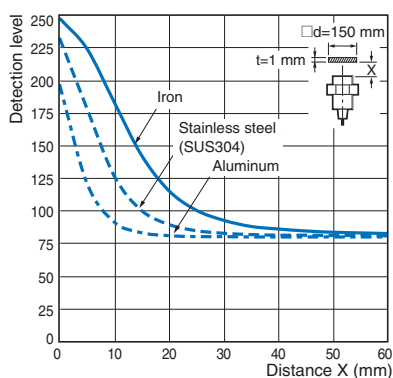

Triple distance model

Size: M8 E2E-X6M□8

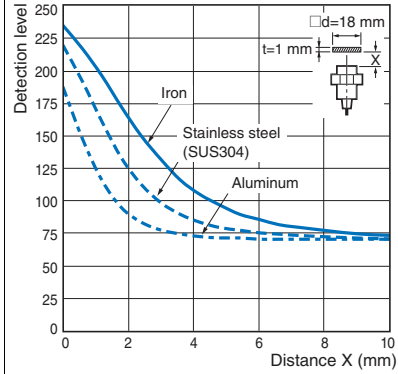

Size: M12 E2E-X10M□12

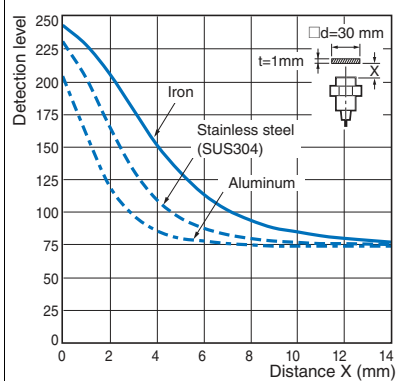

Size: M18 E2E-X20M□18

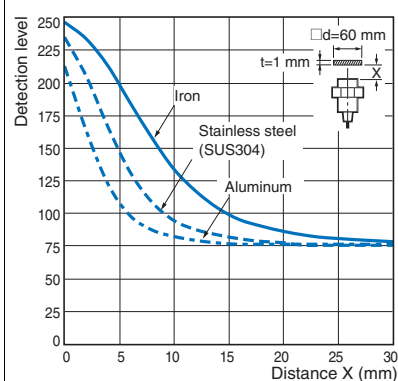

Size: M30 E2E-X40M□30

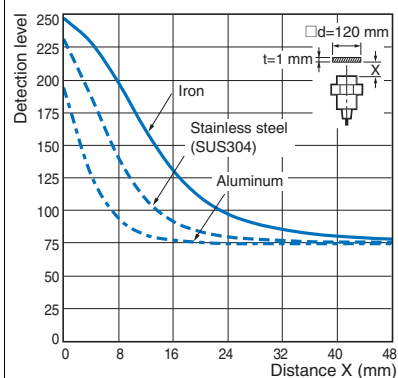

BASIC Model

Shielded

Double distance model, Spatter-resistant Double distance model

Size: M8 E2E(Q)-X2□8

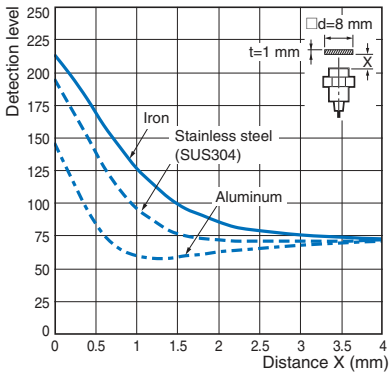

Size: M12 E2E(Q)-X4□12

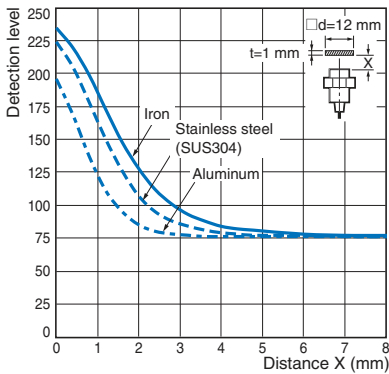

Size: M18 E2E(Q)-X8□18

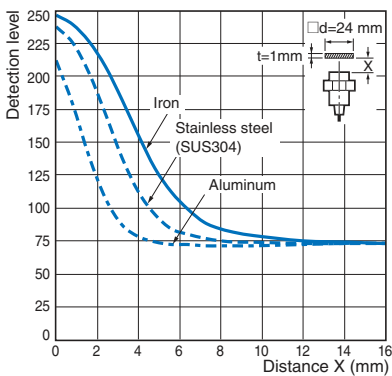

Size: M30 E2E(Q)-X15□30

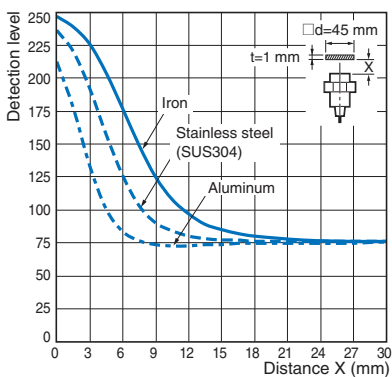

Single distance model, Spatter-resistant Single distance model

Size: M8 E2E(Q)-X1R5□8

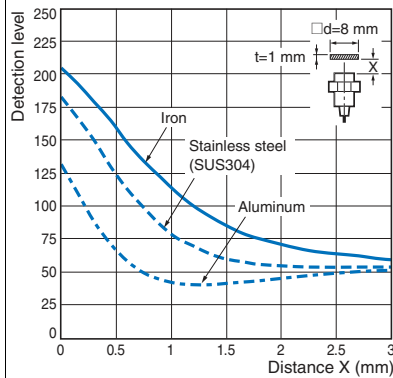

Size: M12 E2E(Q)-X2□12

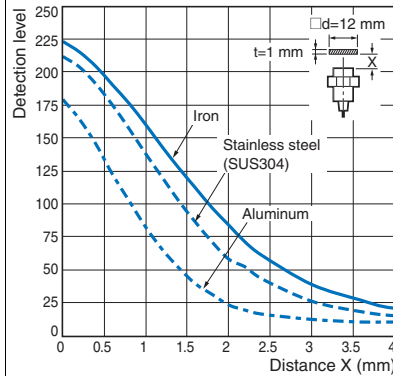

Size: M18 E2E(Q)-X5□18

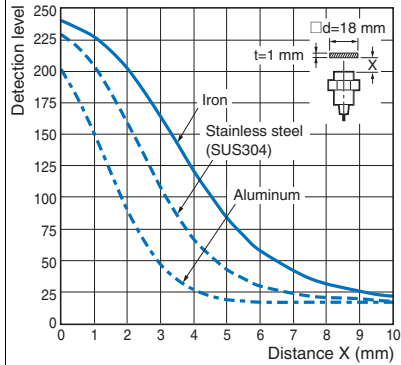

Size: M30 E2E(Q)-X10□30

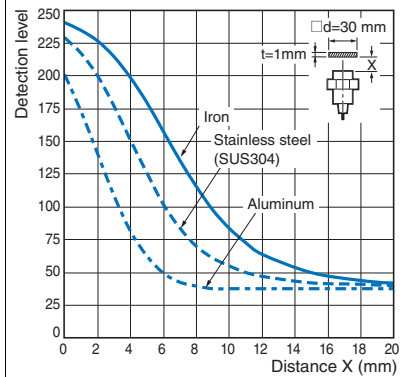

BASIC Model

Unshielded

Double distance model

Size: M8 E2E-X4M□8

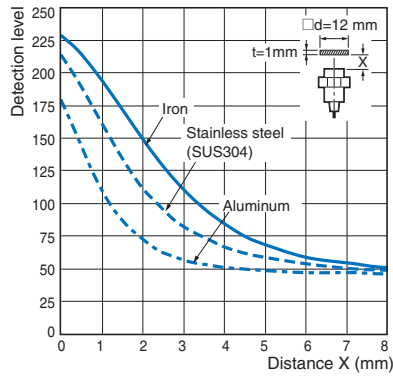

Size: M12 E2E-X8M□12

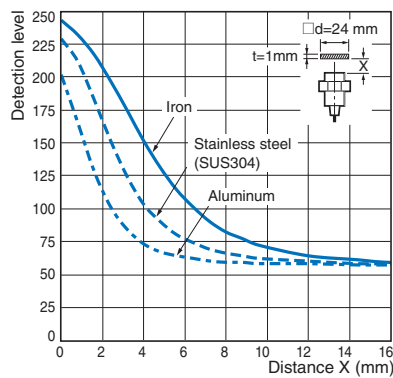

Size: M18 E2E-X16M□18

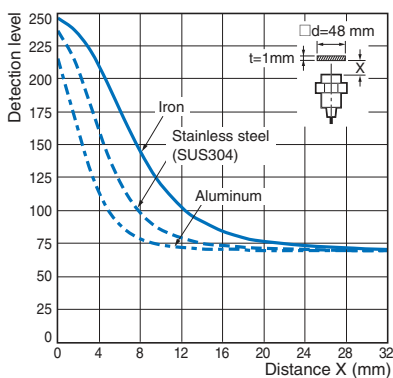

Size: M30 E2E-X30M□30

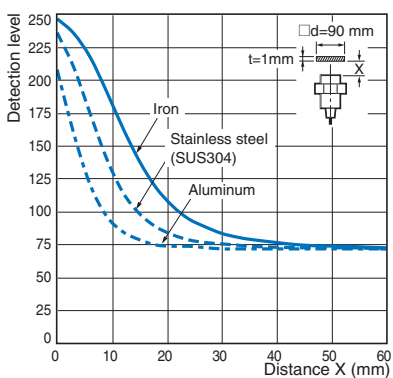

Single distance model

Size: M8 E2E-X2M□8

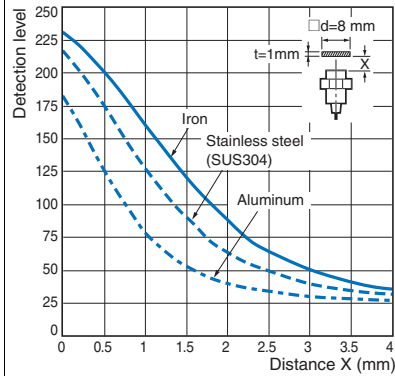

Size: M12 E2E-X5M□12

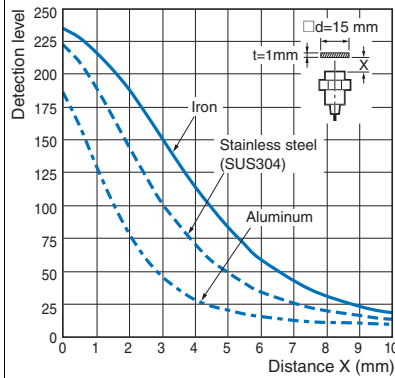

Size: M18 E2E-X10M□18

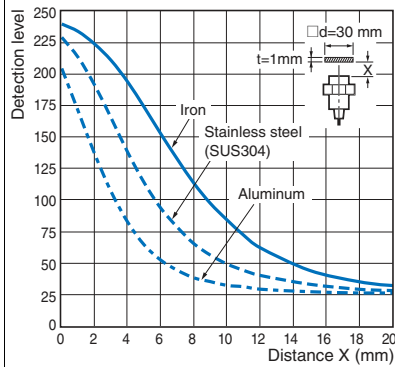

Size: M30 E2E-X18M□30

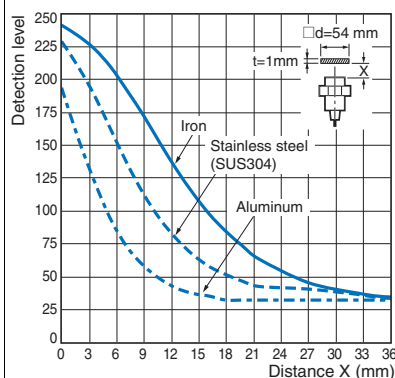

I/O Circuit Diagrams/Timing charts

DC 3-Wire
PNP output

| Operation mode | Model | Output circuit | |
|----------------|------------|---|---|
| | | Standard I/O mode (SIO mode) When using as a general | IO-Link Communication mode (COM mode) When using the Sensor connected to IO-Link Master Unit |
| NO | E2E(Q)-□B1 | | |
| NC | E2E(Q)-□B2 | <p>Note: M8 (3-pin) Connector: (1)(4)(3)</p> | --- |
| NO+NC | E2E(Q)-□B3 | | |

Connector Pin Arrangement

| M12 Connector M12 Smartclick Connector | M8 (4-pin) Connector | M8 (3-pin) Connector |
|---|----------------------|----------------------|
| | | |

PNP output

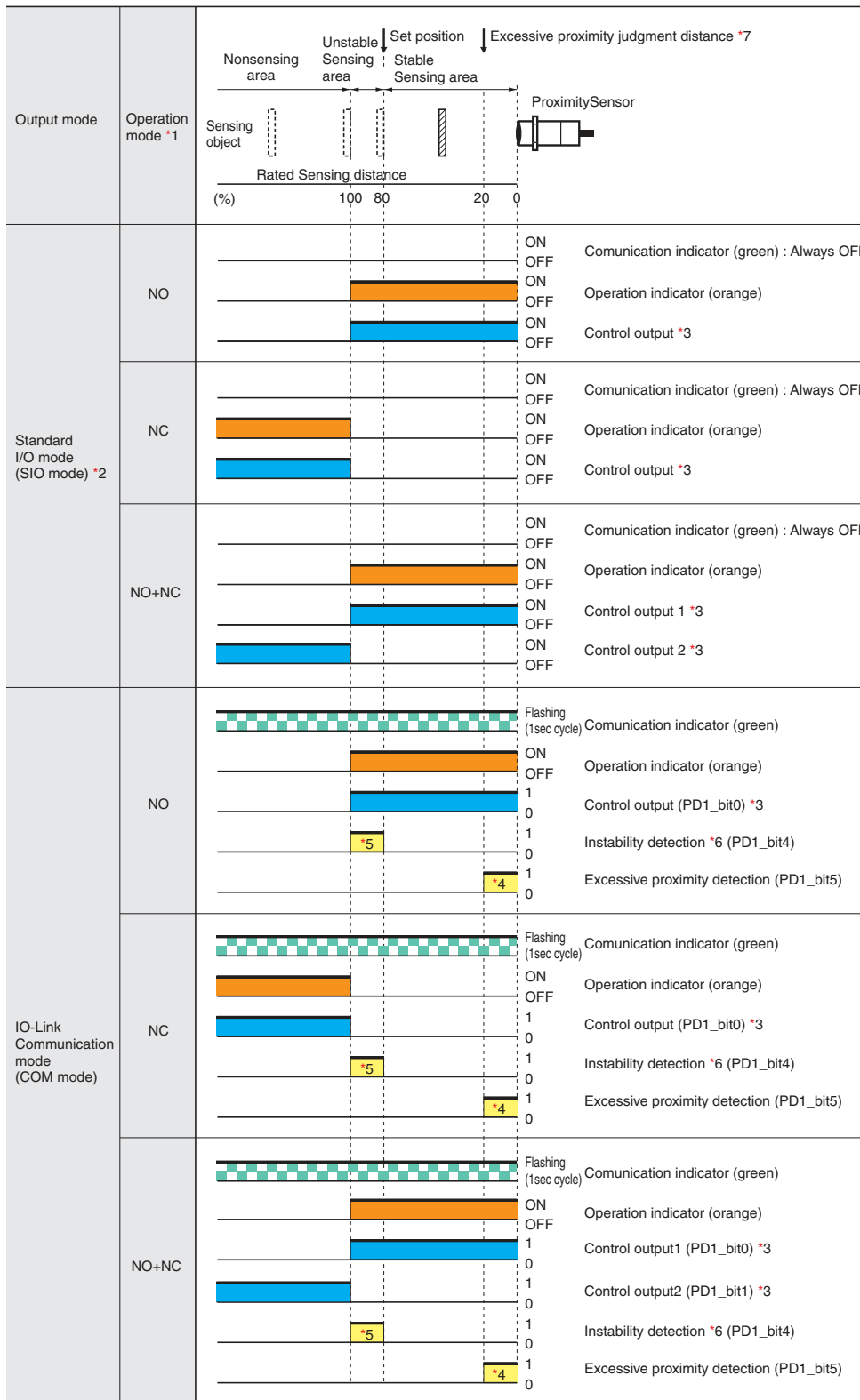

*3. The timer function of the control output can be set up by the IO-Link communications. (It is able to select ON delay, OFF delay, or one-shot function and select a timer time of 1 to 16,383ms (T).)

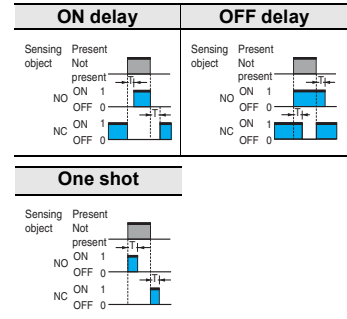

*4. The excessive target proximity diagnosis function can be selected by the IO-Link communications.
 *5. The instability detection diagnosis can be selected by the IO-Link communications.

*6. The judgment time for the instability detection diagnosis can be selected by the IO-Link communications. (For the ON delay timer function, the setting can be selected from 0 (invalid), 10, 50, 100, 300, 500, or 1000 ms.)

*7. The judgment distance of the excessive target proximity diagnosis function can be selected by the IO-Link communications. (The distance can be selected as a combination of the material of the object detected, such as iron, aluminum, or SUS and the sensing distance of approximately 10, 20, or 30%. However, it is not allowed to select a combination of aluminum and 30%.)

Please contact your OMRON sales representative regarding the IO-Link setup file (IODD file).

Please contact your OMRON sales representative regarding assignment of data.

*1. For models with IO-Link, the operation mode can be changed by the IO-Link communications.

*2. If using a model with IO-Link as a general sensor or using a model without IO-Link, it operates in the standard I/O mode (SIO mode).

NPN output

| Operation mode | Model | Output circuit |
|----------------|------------|--|
| NO | E2E(Q)-□C1 | |
| NC | E2E(Q)-□C2 | <p>Note: M8 (3-pin) Connector: (1)(4)(3)</p> |
| NO+NC | E2E(Q)-□C3 | |

Connector Pin Arrangement

| M12 Connector M12 Smartclick Connector | M8 (4-pin) Connector | M8 (3-pin) Connector |
|---|----------------------|----------------------|
| | | |

| Operation mode | Sensing area | | Proximity Sensor | Output | |
|----------------|-----------------|---------------------|------------------|--------|------------------------------|
| | Nonsensing area | Stable sensing area | | ON/OFF | Output Name |
| NO | | | | ON | Operation indicator (orange) |
| | | | | OFF | |
| | | | | ON | Control output |
| | | | | OFF | |
| NC | | | | ON | Operation indicator (orange) |
| | | | | OFF | |
| | | | | ON | Control output |
| | | | | OFF | |
| NO+NC | | | | ON | Operation indicator (orange) |
| | | | | OFF | |
| | | | | ON | Control output 1 |
| | | | | OFF | |
| | | | | ON | Control output 2 |
| | | | | OFF | |

E2E/E2EQ NEXT Series

Connections for Sensor I/O Connectors

DC 3-Wire

| Proximity Sensor | | | | Sensor I/O Connectors | | | | |
|--|---------------------------------------|---------------------------------------|--------------------------|---|--|--|--|---|
| Types | Output | Operation mode | Model | Model | Connections * | | | |
| DC 3-Wire (M12 Connector/ M12 Smartclick Connector) | PNP | NO | E2E(Q)-X□B1□-M1TJ/ M1 | XS5F-D421-□80-X□ XS5F-D42□-□80-F XS5W-D421-□81-X□ XS5W-D42□-□81-F Note: For details of the connector, refer to <i>XS5 NEXT Series</i> on page 87 refer to <i>XS5 Series</i> on page 94 | E2E/E2EQ NEXT Series XS5 ○ Brown (+) ○ White (not connected) ○ Blue (-) ○ Black (Output) | | | |
| | | NC | E2E(Q)-X□B2□-M1TJ/M1 | | E2E/E2EQ NEXT Series XS5 ○ Brown (+) ○ White (Output) ○ Blue (-) ○ Black (not connected) | | | |
| | | NO+NC | E2E(Q)-X□B3□-M1TJ/M1 | | E2E/E2EQ NEXT Series XS5 ○ Brown (+) ○ White (Output 2) ○ Blue (-) ○ Black (Output 1) | | | |
| | | NPN | NO | | E2E(Q)-X□C1□-M1TJ/M1 | E2E/E2EQ NEXT Series XS5 ○ Brown (+) ○ White (not connected) ○ Blue (-) ○ Black (Output) | | |
| | | | NC | | E2E(Q)-X□C2□-M1TJ/M1 | E2E/E2EQ NEXT Series XS5 ○ Brown (+) ○ White (Output) ○ Blue (-) ○ Black (not connected) | | |
| | | | NO+NC | | E2E(Q)-X□C3□-M1TJ/M1 | E2E/E2EQ NEXT Series XS5 ○ Brown (+) ○ White (Output 2) ○ Blue (-) ○ Black (Output 1) | | |
| | DC 3-Wire (M8 Connector, 4-pin) | | PNP | | NO | E2E(Q)-X□B1□-M3 | E2E/E2EQ NEXT Series XS3 ○ Brown (+) ○ White (not connected) ○ Blue (-) ○ Black (Output) | |
| | | | | | NC | E2E(Q)-X□B2□-M3 | XS3W-M8PVC4□ XS3F-M8PVC4□ E2E/E2EQ NEXT Series XS3 ○ Brown (+) ○ White (Output) ○ Blue (-) ○ Black (not connected) | |
| | | | NPN | | NO | E2E(Q)-X□C1□-M3 | E2E/E2EQ NEXT Series XS3 ○ Brown (+) ○ White (not connected) ○ Blue (-) ○ Black (Output) | |
| | | NC | | | E2E(Q)-X□C2□-M3 | E2E/E2EQ NEXT Series XS3 ○ Brown (+) ○ White (Output) ○ Blue (-) ○ Black (not connected) | | |
| | | DC 3-Wire (M8 Connector, 3-pin) | PNP | | NO | E2E(Q)-X□B1□-M5 | XS3W-M8PVC3□ XS3F-M8PVC3□ Note: For details of the connector, refer to <i>XS3W-M8/ XS3F-M8 Series</i> on page 102. | E2E/E2EQ NEXT Series XS3 ○ Brown (+) ○ Black (Output) ○ Blue (-) |
| | | | | | NC | E2E(Q)-X□B2□-M5 | | E2E/E2EQ NEXT Series XS3 ○ Brown (+) ○ Black (Output) ○ Blue (-) |
| NPN | NO | | E2E(Q)-X□C1□-M5 | E2E/E2EQ NEXT Series XS3 ○ Brown (+) ○ Black (Output) ○ Blue (-) | | | | |
| | NC | | E2E(Q)-X□C2□-M5 | E2E/E2EQ NEXT Series XS3 ○ Brown (+) ○ Black (Output) ○ Blue (-) | | | | |

Note: Different from Proximity Sensor wire colors.

* If the XS5W Series or XS3W Series Connector which has a socket and plug on the cable ends is connected to the Sensor, this part will be a plug.



Safety Precautions

Be sure to read the precautions for all models in the website at: <http://www.ia.omron.com/>.

Warning Indications

| | |
|--|--|
|  WARNING | Warning level Indicates a potentially hazardous situation which, if not avoided, will result in minor or moderate injury, or may result in serious injury or death. Additionally there may be significant property damage. |
| Precautions for Safe Use | Supplementary comments on what to do or avoid doing, to use the product safely. |
| Precautions for Correct Use | Supplementary comments on what to do or avoid doing, to prevent failure to operate, malfunction or undesirable effect on product performance. |

Meaning of Product Safety Symbols

| | |
|---|--|
|  | General prohibition Indicates the instructions of unspecified prohibited action. |
|  | Caution, explosion Indicates the possibility of explosion under specific conditions. |

WARNING

This product is not designed or rated for ensuring safety of persons either directly or indirectly. Do not use it for such purposes.



Otherwise, explosion may result. Never use the product with an AC power supply.



Precautions for Safe Use

The following precautions must be observed to ensure safe operation.

- Do not use the product in environments subject to flammable or explosive gases.
- Do not attempt to disassemble, repair, or modify the product.
- Do not use a voltage that exceeds the rated operating voltage range.
Applying a voltage that is higher than the operating voltage range may result in explosion or fire.
- Be sure that the power supply polarity and other wiring is correct. Incorrect wiring may cause explosion or fire.
- If the power supply is connected directly without a load, the internal elements may explode or burn.
- Be sure to insert a load when connecting the power supply.

Precautions for Correct Use

Do not use the product in any atmosphere or environment that exceeds the ratings.

Operating Environment

- Do not install the Sensor in the following locations.
 - Outdoor locations directly subject to sunlight, rain, snow, water droplets, or oil.
 - Locations subject to atmospheres with chemical vapors, in particular solvents and acids.
 - Locations subject to corrosive gases.
- The Sensor may malfunction if used near ultrasonic cleaning equipment, high-frequency equipment, transceivers, cellular phones, inverters, or other devices that generate a high-frequency electric field. Please refer to the Precautions for Correct Use on the OMRON website (www.ia.omron.com) for typical measures.
- Laying the Proximity Sensor wiring in the same conduit or duct as high-voltage wires or power lines may result in incorrect operation and damage due to induction. Wire the Sensor using a separate conduit or independent conduit.
- Never use thinner or other solvents. Otherwise, the Sensor surface may be dissolved.
- The following conditions shall be observed if you use the product under an environment using cutting oil that may affect product's life and/or performance.
 - Usage under the cutting oil condition designated by the specification
 - Usage under the cutting oil dilution ratio recommended by its manufacturer
 - Usage in oil or water is prohibited
 Impact on the product life may differ depending on the oil you use. Before using the cutting oil, make sure that it should not cause deterioration or degradation of sealing components.
- When turning on the power by influence of temperature environment, an output mis-pulse sometimes occurs. After the sensor has passed for 300 msec after turning on, please use in the stable state.
- The sensor is adjusted with a high degree of accuracy, so do not use in the environment with sudden temperature change.
- Operation check is performed using an OMRON's IO-Link master. If using an IO-Link master from another company, perform the operation check in advance.

E2E/E2EQ NEXT Series

Design

Influence of Surrounding Metal

When mounting the Proximity Sensor using a nut, only use the provided nut. And ensure that the minimum distances given in the following table are maintained.

When mounting the Proximity Sensor using a nut, only use the provided nut. Nuts that are supplied along with each Sensor are different. Refer to Dimensions for details on shapes.

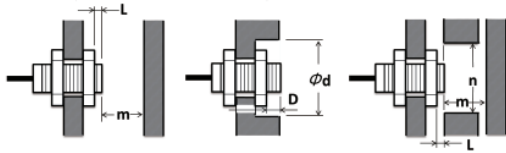

(Unit: mm)

Shielded

| Type | Model | L | d | D | m | n |
|--|---------------|---|-----|---|-----|-----|
| Quadruple distance model | E2E-X4□8 | 3 | 30 | 3 | 12 | 20 |
| | E2E-X9□12 | 2 | 40 | 2 | 27 | 30 |
| | E2E-X14□18 | 2 | 60 | 2 | 42 | 70 |
| | E2E-X23□30 | 2 | 100 | 2 | 69 | 100 |
| Triple distance model/ Spatter-resistant Triple distance model | E2E(Q)-X3□8 | 0 | 20 | 0 | 9 | 18 |
| | E2E(Q)-X6□12 | 0 | 20 | 0 | 18 | 20 |
| | E2E(Q)-X12□18 | 0 | 50 | 0 | 36 | 54 |
| | E2E(Q)-X22□30 | 0 | 70 | 0 | 66 | 90 |
| Double distance model/ Spatter-resistant Double distance model | E2E(Q)-X2□8 | 0 | 8 | 0 | 4.5 | 12 |
| | E2E(Q)-X4□12 | 0 | 18 | 0 | 12 | 18 |
| | E2E(Q)-X8□18 | 0 | 27 | 0 | 24 | 27 |
| | E2E(Q)-X15□30 | 0 | 45 | 0 | 45 | 45 |
| Single distance model/ Spatter-resistant Single distance model | E2E(Q)-X1R5□8 | 0 | 8 | 0 | 4.5 | 12 |
| | E2E(Q)-X2□12 | 0 | 12 | 0 | 8 | 18 |
| | E2E(Q)-X5□18 | 0 | 18 | 0 | 20 | 27 |
| | E2E(Q)-X10□30 | 0 | 30 | 0 | 40 | 45 |

Unshielded

| Models | Model | L | d | D | m | n |
|--------------------------|---------------|----|-----|----|-----|-----|
| Quadruple distance model | E2E-X8M□8 | 12 | 40 | 12 | 24 | 40 |
| | E2E-X16M□12 | 21 | 70 | 21 | 48 | 80 |
| | E2E-X30M□18 | 46 | 130 | 46 | 90 | 110 |
| | E2E-X50M□30 | 60 | 200 | 60 | 150 | 180 |
| Triple distance model | E2E-X6M□8 | 10 | 30 | 10 | 18 | 30 |
| | E2E-X10M□12 | 16 | 50 | 16 | 30 | 50 |
| | E2E-X20M□18 | 31 | 90 | 31 | 60 | 80 |
| | E2E-X40M□30 * | 50 | 170 | 50 | 120 | 140 |
| Double distance model | E2E-X4M□8 | 9 | 24 | 9 | 8 | 24 |
| | E2E-X8M□12 | 11 | 40 | 11 | 20 | 40 |
| | E2E-X16M□18 | 21 | 70 | 21 | 48 | 70 |
| | E2E-X30M□30 | 40 | 120 | 40 | 90 | 120 |
| Single distance model | E2E-X2M□8 | 6 | 24 | 6 | 8 | 24 |
| | E2E-X5M□12 | 11 | 40 | 11 | 20 | 36 |
| | E2E-X10M□18 | 18 | 55 | 18 | 40 | 54 |
| | E2E-X18M□30 | 25 | 90 | 25 | 70 | 90 |

* If you use the model E2E-X40M□30, the panel thickness (t) is 4 mm or less.

When the Proximity Sensor is mounted in metal, ensure that the minimum distances given in the following table are maintained.

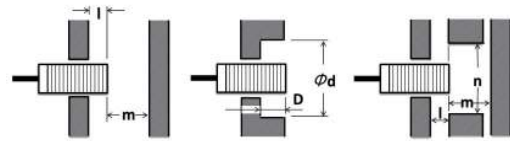

(Unit: mm)

Shielded

| Models | Model | l | d | D | m | n |
|--|---------------|-----|-----|-----|-----|-----|
| Quadruple distance model | E2E-X4□8 | 4 | 30 | 4 | 12 | 20 |
| | E2E-X9□12 | 6 | 40 | 6 | 27 | 30 |
| | E2E-X14□18 | 7 | 60 | 7 | 42 | 70 |
| | E2E-X23□30 | 9 | 100 | 9 | 69 | 100 |
| Triple distance model/ Spatter-resistant Triple distance model | E2E(Q)-X3□8 | 2 | 20 | 2 | 9 | 18 |
| | E2E(Q)-X6□12 | 4 | 20 | 4 | 18 | 20 |
| | E2E(Q)-X12□18 | 4 | 50 | 4 | 36 | 54 |
| | E2E(Q)-X22□30 | 8 | 70 | 8 | 66 | 90 |
| Double distance model/ Spatter-resistant Double distance model | E2E(Q)-X2□8 | 0 | 8 | 0 | 4.5 | 12 |
| | E2E(Q)-X4□12 | 2.4 | 18 | 2.4 | 12 | 18 |
| | E2E(Q)-X8□18 | 3.6 | 27 | 3.6 | 24 | 27 |
| | E2E(Q)-X15□30 | 6 | 45 | 6 | 45 | 45 |
| Single distance model/ Spatter-resistant Single distance model | E2E(Q)-X1R5□8 | 0 | 8 | 0 | 4.5 | 12 |
| | E2E(Q)-X2□12 | 0 | 12 | 0 | 8 | 18 |
| | E2E(Q)-X5□18 | 0 | 18 | 0 | 20 | 27 |
| | E2E(Q)-X10□30 | 0 | 30 | 0 | 40 | 45 |

Unshielded

| Models | Model | l | d | D | m | n |
|--------------------------|---------------|----|-----|----|-----|-----|
| Quadruple distance model | E2E-X8M□8 | 15 | 40 | 15 | 24 | 40 |
| | E2E-X16M□12 | 25 | 70 | 25 | 48 | 80 |
| | E2E-X30M□18 | 50 | 130 | 50 | 90 | 110 |
| | E2E-X50M□30 | 65 | 200 | 65 | 150 | 180 |
| Triple distance model | E2E-X6M□8 | 13 | 30 | 13 | 18 | 30 |
| | E2E-X10M□12 | 20 | 50 | 20 | 30 | 50 |
| | E2E-X20M□18 | 35 | 90 | 35 | 60 | 80 |
| | E2E-X40M□30 * | 55 | 170 | 55 | 120 | 140 |
| Double distance model | E2E-X4M□8 | 12 | 24 | 12 | 8 | 24 |
| | E2E-X8M□12 | 15 | 40 | 15 | 20 | 40 |
| | E2E-X16M□18 | 25 | 70 | 25 | 48 | 70 |
| | E2E-X30M□30 | 45 | 120 | 45 | 90 | 120 |
| Single distance model | E2E-X2M□8 | 6 | 24 | 6 | 8 | 24 |
| | E2E-X5M□12 | 15 | 40 | 15 | 20 | 36 |
| | E2E-X10M□18 | 22 | 55 | 22 | 40 | 54 |
| | E2E-X18M□30 | 30 | 90 | 30 | 70 | 90 |

* If you use the model E2E-X40M□30, the panel thickness (t) is 4 mm or less.

Mutual Interference

When installing two or more Proximity Sensors face-to-face or side-by-side, ensure that the minimum distances given in the following table are maintained.

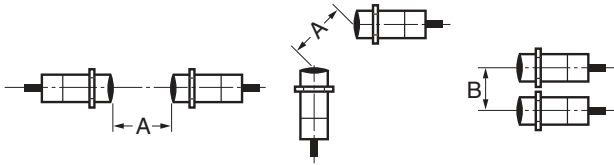

(Unit: mm)

Shielded

| Models | Model | Item | |
|---|---------------|------|----|
| | | A | B |
| Quadruple distance model | E2E-X4□8 | 40 | 20 |
| | E2E-X9□12 | 60 | 35 |
| | E2E-X14□18 | 90 | 50 |
| | E2E-X23□30 | 150 | 90 |
| Triple distance model/ Spatter-resistant Triple distance model | E2E(Q)-X3□8 | 25 | 20 |
| | E2E(Q)-X6□12 | 40 | 30 |
| | E2E(Q)-X12□18 | 70 | 45 |
| | E2E(Q)-X22□30 | 150 | 90 |
| Double distance model/ Spatter-resistant Double distance model | E2E(Q)-X2□8 | 20 | 15 |
| | E2E(Q)-X4□12 | 30 | 20 |
| | E2E(Q)-X8□18 | 60 | 35 |
| | E2E(Q)-X15□30 | 110 | 90 |
| Single distance model/ Spatter-resistant Single distance model | E2E(Q)-X1R5□8 | 20 | 15 |
| | E2E(Q)-X2□12 | 30 | 20 |
| | E2E(Q)-X5□18 | 50 | 35 |
| | E2E(Q)-X10□30 | 100 | 70 |

Unshielded

| Models | Model | Item | |
|--------------------------|-------------|------|-----|
| | | A | B |
| Quadruple distance model | E2E-X8M□8 | 80 | 60 |
| | E2E-X16M□12 | 160 | 120 |
| | E2E-X30M□18 | 360 | 300 |
| | E2E-X50M□30 | 700 | 480 |
| Triple distance model | E2E-X6M□8 | 80 | 60 |
| | E2E-X10M□12 | 120 | 100 |
| | E2E-X20M□18 | 200 | 120 |
| Double distance model | E2E-X4M□8 | 80 | 60 |
| | E2E-X8M□12 | 120 | 100 |
| | E2E-X16M□18 | 200 | 120 |
| | E2E-X30M□30 | 350 | 300 |
| Single distance model | E2E-X2M□8 | 80 | 60 |
| | E2E-X5M□12 | 120 | 100 |
| | E2E-X10M□18 | 200 | 110 |
| | E2E-X18M□30 | 300 | 200 |

Mounting

Tightening Force

Do not tighten the nut with excessive force.
A washer must be used with the nut.

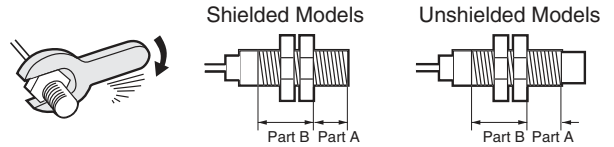

- Note:**
- The allowable tightening strength depends on the distance from the edge of the head, as shown in the following table. (A is the distance from the edge of the head. B includes the nut on the head side. If the edge of the nut is in part A, the tightening torque for part A applies instead.)
 - The following strengths assume washers are being used.

Quadruple distance model, Triple distance model, Spatter-resistant Triple distance model

| Size | Shielded | Part A | | Part B |
|------|------------|----------------|--------|---------------------|
| | | Dimension (mm) | Torque | Torque |
| M8 | Shielded | 9 | 4 N·m | 10 N·m |
| | Unshielded | 3 | | |
| M12 | Shielded | 16 | 6 N·m | 15 N·m |
| | Unshielded | 9 | | |
| M18 | Shielded | 16 | 15 N·m | 60 N·m (30 N·m*) |
| | Unshielded | 3 | | |
| M30 | Shielded | 23 | 40 N·m | 80 N·m |
| | Unshielded | 8 | | |

* If using the E2EQ (M18), refer to this torque value.

Double distance model, Single distance model, Spatter-resistant Triple distance model, Spatter-resistant Single distance model

| Size | Shielded | Part A | | Part B |
|------|------------|----------------|--------------------|--------|
| | | Dimension (mm) | Torque | Torque |
| M8 | Shielded | 9 | 9 N·m | 12 N·m |
| | Unshielded | 3 | | |
| M12 | --- | --- | 30 N·m | |
| M18 | --- | --- | 70 N·m | |
| M30 | --- | --- | 180 N·m (100 N·m*) | |

* If using the E2EQ (M30), refer to this torque value.

Mounting

In the IO-Link mode, the cord between the IO-Link master and sensor must have a length of 20 m or less.

E2E/E2EQ NEXT Series

Dimensions

(Unit: mm)

Tolerance class IT16 applies to dimensions in this data sheet unless otherwise specified.

Sensors

PREMIUM Model

E2E/E2EQ NEXT Series

(Quadruple distance/Triple distance/Spatter-resistant, Triple distance model)

DC 3-Wire

Pre-wired Model/Pre-wired Connector Model
Shielded/Unshielded



Connector Models

(M12 Connector, M8 (4-pin) Connector and M8 (3-pin) Connector)
Shielded/Unshielded

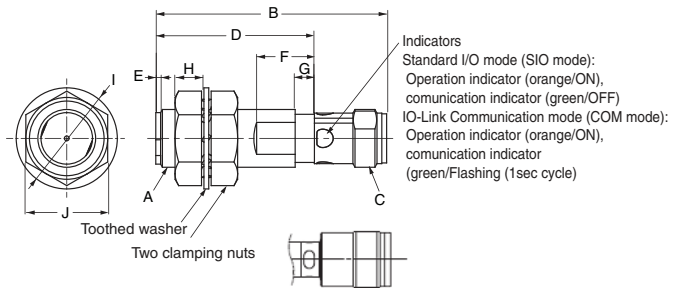
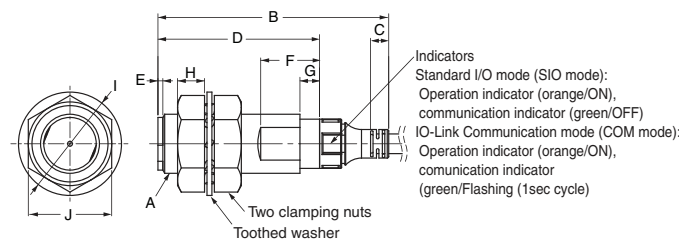

Model E2E(Q)-X□8-M1;
Shape of connection.

Pre-wired Models

(Operation mode: NO, NC Type)

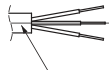

Vinyl-insulated round cable with
3 conductors
M8, M12 size: 4-dia.
M18, M30 size: 6-dia.
(Conductor cross section:
0.2 mm² (AWG24),
Insulator diameter: 1.05 mm),
Standard length: 2 m

(Operation mode: NO+NC Type)

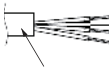

Vinyl-insulated round cable with
4 conductors
M12 size: 4.3-dia.
M18/M30 size: 6-dia.
(Conductor cross section: 0.2 mm²
(AWG24),
Insulator diameter: 1.05 mm),
Standard length: 2 m

Pre-wired Connector Models (M12J)

(Operation mode: NO, NC Type)

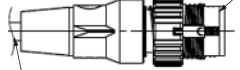

Vinyl-insulated round cable with
3 conductors
M8, M12 size: 4-dia.
M18, M30 size: 6-dia.
(Conductor cross section:
0.2 mm² (AWG24),
Insulator diameter: 1.05 mm),
Standard length: 0.3 m

(Operation mode: NO+NC Type)

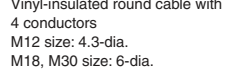

Vinyl-insulated round cable with
4 conductors
M12 size: 4.3-dia.
M18, M30 size: 6-dia.
(Conductor cross section: 0.2 mm²
(AWG24),
Insulator diameter: 1.05 mm),
Standard length: 0.3 m

Shielded

| Model | A | B | C | D | E | F | G* | H | I | J |
|------------------|----------|----|--------|----|---|----|-----|-----|----|----|
| E2E(Q)-X□8-M3/M5 | M8XP1 | 39 | M8XP1 | 26 | 1 | 10 | 4 | 4 | 15 | 13 |
| E2E(Q)-X□8-M1 | M8XP1 | 43 | M12XP1 | 26 | 1 | 10 | 4 | 4 | 15 | 13 |
| E2E(Q)-X□12-M1 | M12XP1 | 48 | M12XP1 | 33 | 1 | 12 | 4 | 5.5 | 21 | 17 |
| E2E(Q)-X□18-M1 | M18XP1 | 53 | M12XP1 | 38 | 1 | 12 | 4 | 6 | 29 | 24 |
| E2E(Q)-X□30-M1 | M30XP1.5 | 58 | M12XP1 | 43 | 1 | 12 | 4 | 7 | 42 | 36 |
| E2E-X□L8-M3/M5 | M8XP1 | 49 | M8XP1 | 36 | 1 | 10 | --- | 4 | 15 | 13 |
| E2E-X□L8-M1 | M8XP1 | 53 | M12XP1 | 36 | 1 | 10 | --- | 4 | 15 | 13 |
| E2E-X□L12-M1 | M12XP1 | 70 | M12XP1 | 55 | 1 | 12 | --- | 5.5 | 21 | 17 |
| E2E-X□L18-M1 | M18XP1 | 75 | M12XP1 | 60 | 1 | 12 | --- | 6 | 29 | 24 |
| E2E-X□L30-M1 | M30XP1.5 | 80 | M12XP1 | 65 | 1 | 12 | --- | 7 | 42 | 36 |

Unshielded

| Model | A | B | C | D | E | F | G* | H | I | J |
|------------------|----------|----|--------|----|----|----|-----|---|----|----|
| E2E-X□M□8-M3/M5 | M8XP1 | 39 | M8XP1 | 26 | 6 | 8 | --- | 3 | 15 | 13 |
| E2E-X□M□8-M1 | M8XP1 | 43 | M12XP1 | 26 | 6 | 8 | --- | 3 | 15 | 13 |
| E2E-X□M□12-M1 | M12XP1 | 48 | M12XP1 | 33 | 7 | 10 | --- | 4 | 21 | 17 |
| E2E-X□M□L8-M3/M5 | M8XP1 | 49 | M8XP1 | 36 | 6 | 8 | --- | 3 | 15 | 13 |
| E2E-X□M□L8-M1 | M8XP1 | 53 | M12XP1 | 36 | 6 | 8 | --- | 3 | 15 | 13 |
| E2E-X□M□L12-M1 | M12XP1 | 70 | M12XP1 | 55 | 7 | 10 | --- | 4 | 21 | 17 |
| E2E-X□M□L18-M1 | M18XP1 | 75 | M12XP1 | 60 | 13 | 12 | --- | 4 | 29 | 24 |
| E2E-X40M□L30-M1 | M30XP1.5 | 80 | M12XP1 | 65 | 15 | 10 | --- | 5 | 42 | 36 |
| E2E-X50M□L30-M1 | M30XP1.5 | 95 | M12XP1 | 80 | 15 | 12 | --- | 5 | 42 | 36 |

Shielded

| Model | A | B | C | D | E | F | G* | H | I | J |
|-------------|----------|------|-----|----|---|----|-----|-----|----|----|
| E2E(Q)-X□8 | M8XP1 | 37.8 | 4.4 | 26 | 1 | 10 | 4 | 4 | 15 | 13 |
| E2E(Q)-X□12 | M12XP1 | 47.1 | 3.7 | 33 | 1 | 12 | 4 | 5.5 | 21 | 17 |
| E2E(Q)-X□18 | M18XP1 | 55.3 | 8.5 | 38 | 1 | 12 | 4 | 6 | 29 | 24 |
| E2E(Q)-X□30 | M30XP1.5 | 60.3 | 8.3 | 43 | 1 | 12 | 4 | 7 | 42 | 36 |
| E2E-X□L8 | M8XP1 | 47.8 | 4.4 | 36 | 1 | 10 | --- | 4 | 15 | 13 |
| E2E-X□L12 | M12XP1 | 69.1 | 3.7 | 55 | 1 | 12 | --- | 5.5 | 21 | 17 |
| E2E-X□L18 | M18XP1 | 77.3 | 8.5 | 60 | 1 | 12 | --- | 6 | 29 | 24 |
| E2E-X□L30 | M30XP1.5 | 82.3 | 8.3 | 65 | 1 | 12 | --- | 7 | 42 | 36 |

Unshielded

| Model | A | B | C | D | E | F | G* | H | I | J |
|-------------|----------|------|-----|----|----|----|-----|---|----|----|
| E2E-X□M□8 | M8XP1 | 37.8 | 4.4 | 26 | 6 | 8 | --- | 3 | 15 | 13 |
| E2E-X□M□12 | M12XP1 | 47.1 | 3.7 | 33 | 7 | 10 | --- | 4 | 21 | 17 |
| E2E-X□M□L8 | M8XP1 | 47.8 | 4.4 | 36 | 6 | 8 | --- | 3 | 15 | 13 |
| E2E-X□M□L12 | M12XP1 | 69.1 | 3.7 | 55 | 7 | 10 | --- | 4 | 21 | 17 |
| E2E-X□M□L18 | M18XP1 | 77.3 | 8.5 | 60 | 13 | 12 | --- | 4 | 29 | 24 |
| E2E-S05S12□ | M30XP1.5 | 82.3 | 8.3 | 65 | 15 | 10 | --- | 5 | 42 | 36 |
| E2E-S05S12□ | M30X1.5 | 97.3 | 8.3 | 80 | 15 | 12 | --- | 5 | 42 | 36 |

* Mounting part of sensor lock O-ring (Y92E-J□S□) ---: Out of a subject.

Mounting Hole Dimensions



| Dimensions | F (mm) |
|------------|-----------------------|
| M8 | 8.5 dia. $^{+0.5}_0$ |
| M12 | 12.5 dia. $^{+0.5}_0$ |
| M18 | 18.5 dia. $^{+0.5}_0$ |
| M30 | 30.5 dia. $^{+0.5}_0$ |

Angle R of the Bending Wire

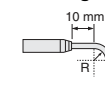

| Dimensions | R (mm) |
|------------|--------|
| M8 | 12 |
| M12 | 12 |
| M18 | 18 |
| M30 | 18 |

Wire pullout position

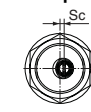

| Dimensions | Sc (mm) |
|------------|---------|
| M8 | - (0) |
| M12 | - (0) |
| M18 | 2.5 |
| M30 | 2.5 |

BASIC Model

E2E/E2EQ NEXT Series

(Double distance/Single distance/Spatter-resistant, Double distance/Single distance model)

DC 3-Wire

Pre-wired Model/Pre-wired Connector Model
Shielded/Unshielded

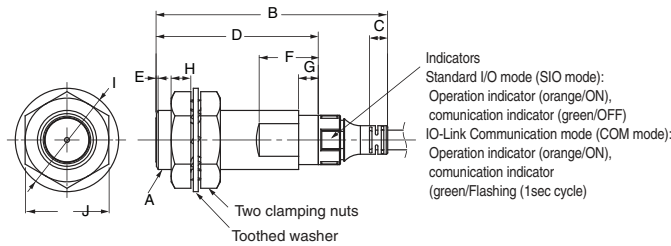

Pre-wired Models
(Operation mode: NO, NC Type)

Pre-wired Connector Models (M1TJ)
M12xP1

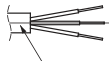

Vinyl-insulated round cable with
3 conductors
M8, M12 size: 4-dia.
M18, M30 size: 6-dia.
(Conductor cross section:
0.2 mm² (AWG24),
Insulator diameter: 1.05 mm),
Standard length: 2 m

(Operation mode: NO+NC Type)

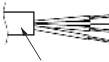

Vinyl-insulated round cable with
4 conductors
M12 size: 4.3-dia.
M18, M30 size: 6-dia.
(Conductor cross section: 0.2 mm²
(AWG24),
Insulator diameter: 1.05 mm),
Standard length: 2 m

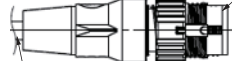

(Operation mode: NO, NC Type)
Vinyl-insulated round cable with
3 conductors
M8, M12 size: 4-dia.
M18, M30 size: 6-dia.
(Conductor cross section:
0.2 mm² (AWG24),
Insulator diameter: 1.05 mm),
Standard length: 0.3 m

(Operation mode: NO+NC Type)
Vinyl-insulated round cable with
4 conductors
M12 size: 4.3-dia.
M18, M30 size: 6-dia.
(Conductor cross section: 0.2 mm²
(AWG24),
Insulator diameter: 1.05 mm),
Standard length: 0.3 m

Shielded

| Model | A | B | C | D | E | F*1 | G*2 | H | I | J |
|-------------|----------|------|-----|----|-----|---------|-----|---|----|----|
| E2E(Q)-X□8 | M8XP1 | 37.8 | 4.4 | 26 | --- | 10 (8) | 4 | 3 | 15 | 13 |
| E2E(Q)-X□12 | M12XP1 | 47.1 | 3.7 | 33 | --- | 12 (10) | 4 | 4 | 21 | 17 |
| E2E(Q)-X□18 | M18XP1 | 55.3 | 8.5 | 38 | --- | 12 (10) | 4 | 4 | 29 | 24 |
| E2E(Q)-X□30 | M30XP1.5 | 60.3 | 8.3 | 43 | --- | 12 (10) | 4 | 5 | 42 | 36 |
| E2E-X□L8 | M8XP1 | 47.8 | 4.4 | 36 | --- | 8 | --- | 3 | 15 | 13 |
| E2E-X□L12 | M12XP1 | 69.1 | 3.7 | 55 | --- | 10 | --- | 4 | 21 | 17 |
| E2E-X□L18 | M18XP1 | 77.3 | 8.5 | 60 | --- | 10 | --- | 4 | 29 | 24 |
| E2E-X□L30 | M30XP1.5 | 82.3 | 8.3 | 65 | --- | 10 | --- | 5 | 42 | 36 |

Unshielded

| Model | A | B | C | D | E*3 | F | G*2 | H | I | J |
|-------------|----------|------|-----|----|----------|----|-----|---|----|----|
| E2E-X□M□8 | M8XP1 | 37.8 | 4.4 | 26 | 6 | 8 | --- | 3 | 15 | 13 |
| E2E-X□M□12 | M12XP1 | 47.1 | 3.7 | 33 | 7 | 10 | --- | 4 | 21 | 17 |
| E2E-X□M□18 | M18XP1 | 55.3 | 8.5 | 38 | 10 | 10 | --- | 4 | 29 | 24 |
| E2E-X□M□30 | M30XP1.5 | 60.3 | 8.3 | 43 | 13 | 10 | --- | 5 | 42 | 36 |
| E2E-X□M□L8 | M8XP1 | 47.8 | 4.4 | 36 | 6 | 8 | --- | 3 | 15 | 13 |
| E2E-X□M□L12 | M12XP1 | 69.1 | 3.7 | 55 | 7 | 10 | --- | 4 | 21 | 17 |
| E2E-X□M□L18 | M18XP1 | 77.3 | 8.5 | 60 | 10 | 10 | --- | 4 | 29 | 24 |
| E2E-X□M□L30 | M30XP1.5 | 82.3 | 8.3 | 65 | 130 (15) | 10 | --- | 5 | 42 | 36 |

*1. If using the E2EQ, refer to () dimensions.

*2. Mounting part of sensor lock O-ring (Y92E-J□S□) ---: Out of a subject.

*3. When using X30M□30, refer to (15).

Connector Models

(M12 Connector, M8 (4-pin) Connector and M8 (3-pin) Connector)
Shielded/Unshielded

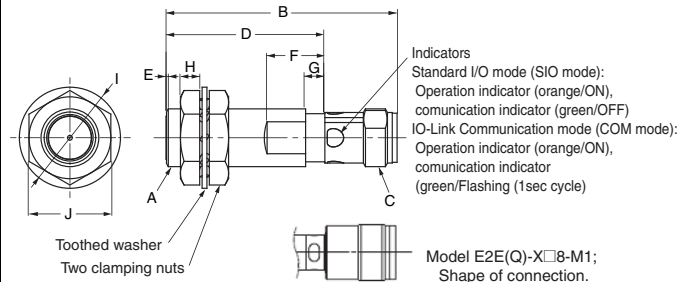

Shielded

| Model | A | B | C | D | E | F*1 | G*2 | H | I | J |
|--------------------------|----------|----|--------|----|-----|------------|-----|---|----|----|
| E2E(Q)-X□30 X□8-M3/M5 | M8XP1 | 39 | M8XP1 | 26 | --- | 10 (8) | 4 | 3 | 15 | 13 |
| E2E(Q)-X□8-M1 | M8XP1 | 43 | M12XP1 | 26 | --- | 10 (8) | 4 | 3 | 15 | 13 |
| E2E(Q)-X□12-M1 | M12XP1 | 48 | M12XP1 | 33 | --- | 12 (10) | 4 | 4 | 21 | 17 |
| E2E(Q)-X□18-M1 | M18XP1 | 53 | M12XP1 | 38 | --- | 12 (10) | 4 | 4 | 29 | 24 |
| E2E(Q)-X□30-M1 | M30XP1.5 | 58 | M12XP1 | 43 | --- | 12 (10) | 4 | 5 | 42 | 36 |
| E2E-X□L8-M3/M5 | M8XP1 | 49 | M8XP1 | 36 | --- | 8 | --- | 3 | 15 | 13 |
| E2E-X□L8-M1 | M8XP1 | 53 | M12XP1 | 36 | --- | 8 | --- | 3 | 15 | 13 |
| E2E-X□L12-M1 | M12XP1 | 70 | M12XP1 | 55 | --- | 10 | --- | 4 | 21 | 17 |
| E2E-X□L18-M1 | M18XP1 | 75 | M12XP1 | 60 | --- | 10 | --- | 4 | 29 | 24 |
| E2E-X□L30-M1 | M30XP1.5 | 80 | M12XP1 | 65 | --- | 10 | --- | 5 | 42 | 36 |

Unshielded

| Model | A | B | C | D | E*3 | F | G*2 | H | I | J |
|------------------|----------|----|--------|----|-------------|----|-----|---|----|----|
| E2E-X□M□8-M3/M5 | M8XP1 | 39 | M8XP1 | 26 | 6 | 8 | --- | 3 | 15 | 13 |
| E2E-X□M□8-M1 | M8XP1 | 43 | M12XP1 | 26 | 6 | 8 | --- | 3 | 15 | 13 |
| E2E-X□M□12-M1 | M12XP1 | 48 | M12XP1 | 26 | 7 | 10 | --- | 4 | 21 | 17 |
| E2E-X□M□18-M1 | M18XP1 | 53 | M12XP1 | 38 | 10 | 10 | --- | 4 | 29 | 24 |
| E2E-X□M□30-M1 | M30XP1.5 | 58 | M12XP1 | 43 | 13 | 10 | --- | 5 | 42 | 36 |
| E2E-X□M□L8-M3-M5 | M8XP1 | 49 | M8XP1 | 36 | 6 | 8 | --- | 3 | 15 | 13 |
| E2E-X□M□L8-M1 | M8XP1 | 53 | M12XP1 | 36 | 6 | 8 | --- | 3 | 15 | 13 |
| E2E-X□M□L12-M1 | M12XP1 | 70 | M12XP1 | 55 | 7 | 10 | --- | 4 | 21 | 17 |
| E2EX□M□L18-M1 | M18XP1 | 75 | M12XP1 | 60 | 10 | 10 | --- | 4 | 29 | 24 |
| E2E-X□M□L30-M1 | M30XP1.5 | 80 | M12XP1 | 65 | 130 (15) | 10 | --- | 5 | 42 | 36 |

*1. If using the E2EQ, refer to () dimensions.

*2. Mounting part of sensor lock O-ring (Y92E-J□S□) ---: Out of a subject.

*3. When using X30M□30, refer to (15).

Mounting Hole Dimensions



| Dimensions | F (mm) |
|------------|--------------------------|
| M8 | 8.5 dia. $+0.5$ -0 |
| M12 | 12.5 dia. $+0.5$ -0 |
| M18 | 18.5 dia. $+0.5$ -0 |
| M30 | 30.5 dia. $+0.5$ -0 |

Angle R of the Bending Wire

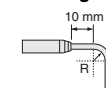

| Dimensions | R (mm) |
|------------|--------|
| M8 | 12 |
| M12 | 12 |
| M18 | 18 |
| M30 | 18 |

Wire pullout position

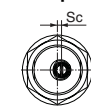

| Dimensions | Sc (mm) |
|------------|---------|
| M8 | - (0) |
| M12 | - (0) |
| M18 | 2.5 |
| M30 | 2.5 |

E2E/E2EQ NEXT Series

Accessories (Sold Separately)

e-jig (Mounting Sleeves)

Y92E-J8S12

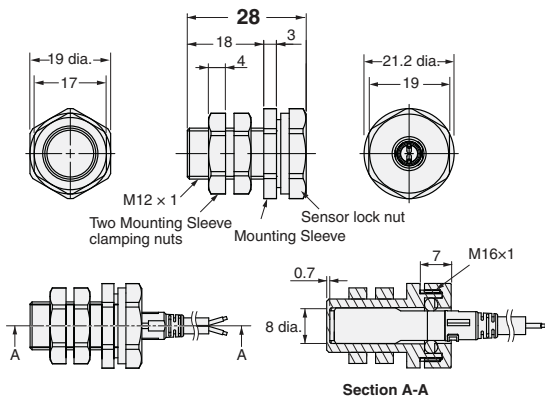

Y92E-J12S18

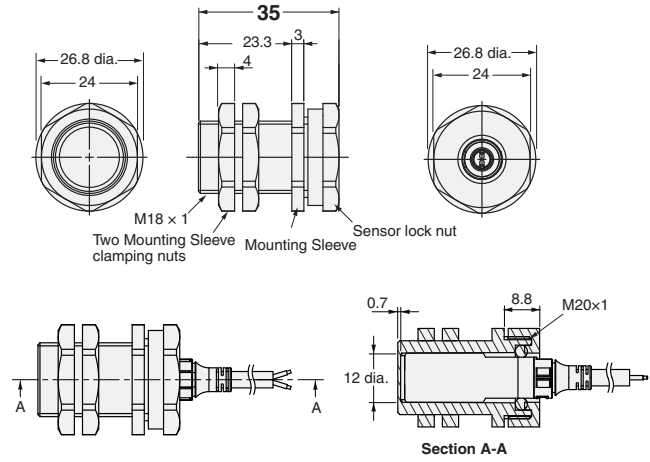

Y92E-J18S30

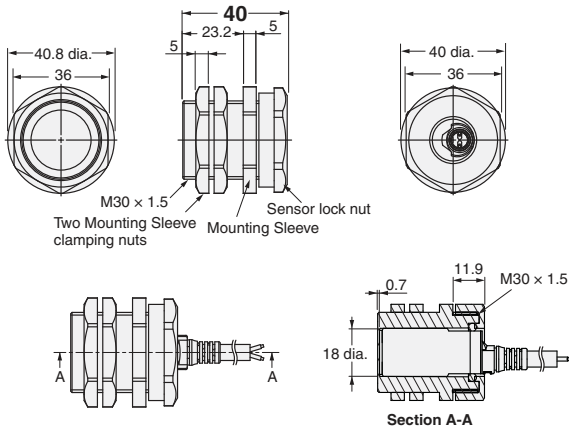

Material

| | |
|------------------------------|--|
| Mounting Sleeve | Polyetheretherketone (PEEK) / Polybutylene terephthalate (PBT) |
| Mounting Sleeve clamping nut | Polybutylene terephthalate (PBT) |
| Sensor lock nut | Polybutylene terephthalate (PBT) |
| Sensor lock O-ring | Material combining HNBR and fluororubber |

Tightening Force

| Model | Torque | |
|-------------|------------------------------|-----------------|
| | Mounting Sleeve clamping nut | Sensor lock nut |
| Y92E-J8S12 | 0.6 N·m | 0.6 N·m |
| Y92E-J12S18 | 1.2 N·m | 1.2 N·m |
| Y92E-J18S30 | 5 N·m | 3.5 N·m |

OMRON AUTOMATION AMERICAS HEADQUARTERS • Chicago, IL USA • 847.843.7900 • 800.556.6766 • automation.omron.com

OMRON CANADA, INC. • HEAD OFFICE

Toronto, ON, Canada • 416.286.6465 • 866.986.6766 • automation.omron.com

OMRON ELECTRONICS DE MEXICO • HEAD OFFICE

Ciudad de México • 52.55.5901.4300 • 01.800.386.6766 • mela@omron.com

OMRON ELECTRONICS DE MEXICO • SALES OFFICE

San Pedro Garza García, N.L. • 81.12.53.7392 • 01.800.386.6766 • mela@omron.com

OMRON ELECTRONICS DE MEXICO • SALES OFFICE

Eugenio Garza Sada, León, Gto • 01.800.386.6766 • mela@omron.com

OMRON ELETRÔNICA DO BRASIL LTDA • HEAD OFFICE

São Paulo, SP, Brasil • 55.11.2101.6300 • www.omron.com.br

OMRON ARGENTINA • SALES OFFICE

Buenos Aires, Argentina • +54.11.4521.8630 • +54.11.4523.8483
mela@omron.com

OTHER OMRON LATIN AMERICA SALES

+54.11.4521.8630 • +54.11.4523.8483 • mela@omron.com

Authorized Distributor:

Controllers & I/O

- Machine Automation Controllers (MAC) • Motion Controllers
- Programmable Logic Controllers (PLC) • Temperature Controllers • Remote I/O

Robotics

- Industrial Robots • Mobile Robots

Operator Interfaces

- Human Machine Interface (HMI)

Motion & Drives

- Machine Automation Controllers (MAC) • Motion Controllers • Servo Systems
- Frequency Inverters

Vision, Measurement & Identification

- Vision Sensors & Systems • Measurement Sensors • Auto Identification Systems

Sensing

- Photoelectric Sensors • Fiber-Optic Sensors • Proximity Sensors
- Rotary Encoders • Ultrasonic Sensors

Safety

- Safety Light Curtains • Safety Laser Scanners • Programmable Safety Systems
- Safety Mats and Edges • Safety Door Switches • Emergency Stop Devices
- Safety Switches & Operator Controls • Safety Monitoring/Force-guided Relays

Control Components

- Power Supplies • Timers • Counters • Programmable Relays
- Digital Panel Meters • Monitoring Products

Switches & Relays

- Limit Switches • Pushbutton Switches • Electromechanical Relays
- Solid State Relays

Software

- Programming & Configuration • Runtime