

PFC-650 Series

Univerter® Power Factor Correction Module

650 Watt PFC Front End

The Univerter PFC-650 Power Factor Correction modules are AC to DC converters that operate from wide range AC input voltages and frequencies with extremely high conversion efficiency and near unity power factor, producing an output of 375VDC. The PFC-650U operates from the universal input voltage range of 90 to 265VAC and input frequencies in the range of 47 to 440Hz making it ideal for applications requiring Power Factor Correction the world over. Model PFC-650W is optimized for input voltages in the 90 to 180VAC range and input frequencies in the range of 330 to 880Hz making it an ideal choice for both military and commercial aircraft applications. These compact power modules use advanced electrical design and thermal management techniques that make them suitable for rugged, environmentally challenged applications.



Compact 3/4 Brick Package
3.6 x 2.4 x 0.5 in.

FEATURES

- Extremely High Efficiency – 94% typ
- Near Unity Power Factor – 0.99 typ.
- High Power Density – 150W/in³
- -40°C to +100 °C Operation Standard
- -55°C to +100 °C Operation Optional
- Extremely Low Thermal Resistance
- Conduction Cooled
- Rugged Encapsulated Package
- Active Inrush Current Limiting
- LD ENA Signal Controls Downstream Converters
- MIL-STD-704/DO-160 Compatible

MODEL SELECTION

MODEL	Input Voltage, VAC	Input Frequency, Hz
PFC-650U	90 - 265	47 - 440
PFC-650W	90 - 180	330 - 880

Typical Application:

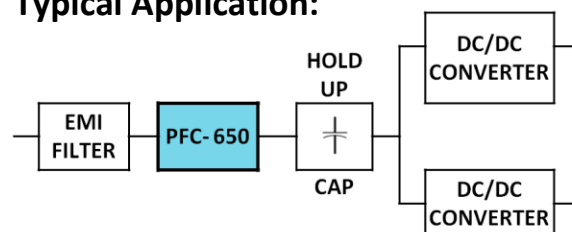

PFC-650 Series

650 Watt Power Factor Correction Module
375 VDC Output, ¾ Brick Package



ABSOLUTE MAXIMUM RATINGS Exceeding absolute maximum ratings may cause permanent damage or reduce reliability					
PARAMETER	OPTION	MINIMUM	MAXIMUM	UNITS	CONDITIONS
Input Voltage (AC1 to AC2)			265	VAC	Continuous
Input Voltage (AC1 to AC2)			311	VAC	100ms max.
LD ENA Voltage (LD ENA to -Vout)		-0.3	15.0	Vdc	
Circuit-to-Case Voltage			2500	Vdc	
Storage Temperature	Standard	-55	110	°C	
	T	-55	110	°C	
	E	-55	125	°C	
Operating Temperature	Standard	-40	100	°C	Baseplate
	T	-55	100	°C	Baseplate
	E	-55	125	°C	Baseplate
Soldering Temperature			260	°C	< 5 sec

SPECIFICATIONS

Electrical specifications apply for Vin = 115VAC, 60Hz (400Hz for PFC-650W model) Full Load, Tc=25 °C unless specified otherwise

INPUT SPECIFICATIONS	MINIMUM	TYPICAL	MAXIMUM	UNITS	CONDITIONS		
Input Voltage	90	115/230	265	VAC			
						PFC-650U	
PFC-650W	90	115	180	VAC			
Input Line Frequency	47	50/60/400	440	Hz			
						PFC-650U	
PFC-650W	330	400/600	880	Hz			
Power Factor		0.999			Vin = 115VAC, 60 Hz, Full Load		
					PFC-650U	0.990	Vin = 230VAC, 50 Hz, Full Load
					PFC-650W	0.980	Vin =115VAC, 400 Hz, Full Load

PFC-650 Series

650 Watt Power Factor Correction Module
375 VDC Output, ¾ Brick Package



SPECIFICATIONS (continued)

Electrical specifications apply for Vin = 115VAC, 60Hz (400Hz for PFC-650W model) Full Load, Tc=25 °C unless specified otherwise

Maximum Input Current		8.1		Arms	Vin = 90VAC, Full Load, Tc = 25°C
			6.2	Arms	Vin = 115VAC, Tc = 100°C
Inrush Current					
PFC-650U		25			Using 15Ω external Rss.
PFC-650W		10		A	115VAC, 400Hz
Start-up Voltage	70	80	85	VAC	
Input Under Voltage	65	75	85	VAC	
Ride Through Time 1		75		mS	Vin = 115VAC, 60 Hz, Half Load, C hold up = 440uF. Note: Ride through is indefinite if output is held above 250 VDC.
Ride Through Time 2		150		mS	Vin = 115VAC, 60 Hz, Half Load, C hold up = 880uF. Note: Ride through is indefinite if output is held above 250 VDC.

OUTPUT SPECIFICATIONS	MINIMUM	TYPICAL	MAXIMUM	UNITS	CONDITIONS
Output Voltage	370	375	380	Vdc	Vin = 115VAC, Tc = 25°C
Output Current	0		1.75	ADC	
Output Current Limit		NONE			
Ripple					
PFC-650U		30		V p-p	Vin = 115VAC, 60Hz, C hold up = 440uF
PFC-650W		30		V p-p	Vin = 115VAC, 400Hz, C hold up = 136uF
Hold Up Capacitance					
PFC-650U	220		1000	μF	
PFC-650W	40		220	μF	
Efficiency					
PFC-650U		0.990			Vin = 115VAC, 60 Hz, Full Load
PFC-650U		0.999			Vin = 230VAC, 50 Hz, Full Load
PFC-650W		0.94			Vin = 115VAC, 400 Hz, Full Load

PFC-650 Series

650 Watt Power Factor Correction Module
375 VDC Output, ¾ Brick Package



SPECIFICATIONS (continued)

Electrical specifications apply for $V_{in} = 115VAC, 60Hz$ (400Hz for PFC-650W model) Full Load, $T_c = 25^\circ C$ unless specified otherwise

CONTROL SPECIFICATIONS	MINIMUM	TYPICAL	MAXIMUM	UNITS	CONDITIONS
LD ENA Threshold (Vout rising)	320		360	Vdc	
LD ENA threshold (Vout falling)	205		235	Vdc	
LD ENA Logic Low Current			20	mA	
LD ENA Logic Low Voltage			0.5	Vdc	LD ENA LOGIC LOW SINK CURRENT = 10mA

ISOLATION SPECIFICATIONS	MINIMUM	TYPICAL	MAXIMUM	UNITS	CONDITIONS
Input-to-Output Isolation		Non-isolated		Vdc	
Input-to-Case Isolation	2500			Vdc	
Output-to-Case Isolation	2500			Vdc	
Circuit-to-Case Capacitance		10		nF	

THERMAL/ MECHANICAL SPECIFICATIONS	MINIMUM	TYPICAL	MAXIMUM	UNITS	CONDITIONS
Thermal Shutdown Temperature		105		°C	Baseplate temp
Thermal Shutdown Restart Temperature		85		°C	Baseplate temp
Thermal Resistance, Case to Ambient		4.2		°C/W	Natural Convection in Free Air, No Heatsink, $T_c = 100^\circ C$
Size, l x w x h	0.5 x 2.4 x 3.6 (12.7 x 61.0 x 91.4)			in (mm)	¾ Brick, See Outline Drawing
Weight	5.7 (161)			oz. (gm)	

EMC COMPLIANCE	EXTERNAL FILTER	COMPLIANCE
MIL-STD-461E	FA250-6	YES

RELIABILITY	MINIMUM	TYPICAL	MAXIMUM	UNITS	CONDITIONS
MTBF Prediction		1.8		M hrs	MIL-217F GB 25°C

PFC-650 Series

650 Watt Power Factor Correction Module
375 VDC Output, ¾ Brick Package



see the applications notes or consult the factory for more information.

RSS

This terminal is internally connected to inrush control circuitry on model PFC-650U and is N/C on model PFC-650W. Model PFC-650W has a built in inrush limiting resistor whereas for model PFC-650U the resistor must be provided externally. For PFC-650U, connect one end of the inrush limiting resistor to this terminal. The other end of the resistor will be connected to -Out. The external inrush resistor

must be chosen to handle the inrush energy which is determined by the input voltage and hold-up capacitor value selected. The inrush connection diagram provides some specific recommendations. Consult the factory for assistance or additional information on selecting an inrush resistor.

-Out

This is the PFC negative output terminal. It should be connected to the negative terminal of the hold up capacitor. For model PFC-650U, connect one end of the inrush resistor to this terminal.

Application Diagram

The connection diagram below shows proper connections between PFC-650 modules, hold-up capacitor, inrush limiting resistor (if required) and DC/DC converters.

For PFC-650W, the inrush limiting resistor is built-in and an external resistor is not required. The resistor is appropriately sized for a maximum input voltage of 180VAC and a maximum external hold-up capacitor value of 220uF.

For PFC-650U, an external inrush limiting resistor must be provided and connected as shown in the connection diagram for PFC-650U. A resistor with high surge handling capability should be used. The maximum input voltage, external hold-up capacitor value and temperature must be considered in choosing a resistor. The maximum RMS input voltage and resistor value will determine the maximum inrush current. A resistor value between 10 and 20 ohms should be chosen. The surge energy in the resistor is that required to charge the hold-

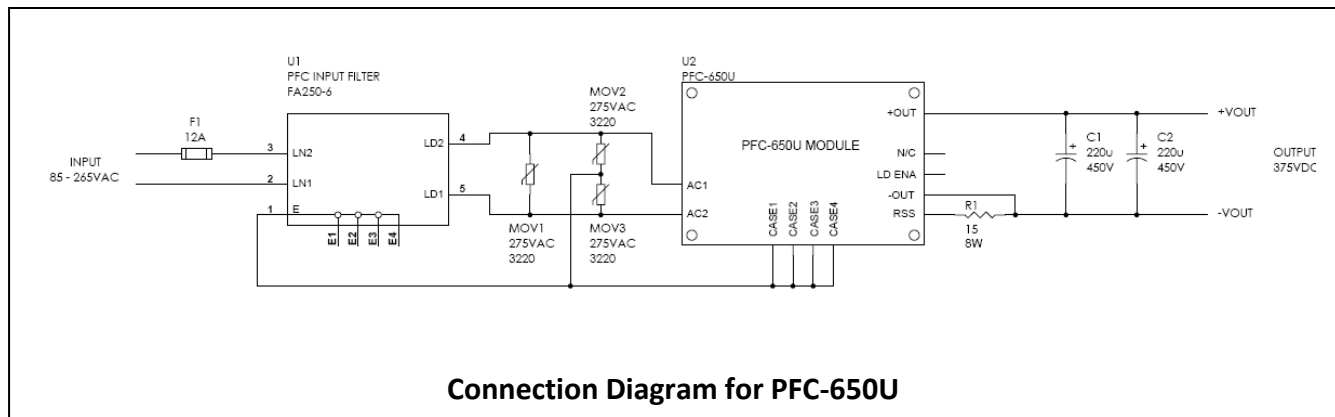

Connection Diagram for PFC-650U

up capacitor up to the peak of the line. After that, internal circuitry will both bypass the external resistor with essentially a short circuit and limit additional inrush current.

PFC-650 Series

650 Watt Power Factor Correction Module
375 VDC Output, 3/4 Brick Package

