

Using the [EVAL-5CH6CHSOICEBZ](#) *i*Coupler Standard Data Isolator Evaluation Board

FEATURES

- Access to all data channels
- Multiple connection options
- Support for active probes
- Provisions for cable terminations
- Support for printed circuit board (PCB) edge mounted coaxial connectors
- Easy configuration

SUPPORTED *i*Coupler DEVICES

Sample *i*Coupler digital isolators must be ordered separately; supported *i*Coupler devices are as follows:

- [ADuM150N/ADuM151N/ADuM152N](#)
- [ADuM160N/ADuM161N/ADuM162N/ADuM163N](#)
- [ADuM250N/ADuM251N/ADuM252N](#)
- [ADuM260N/ADuM261N/ADuM262N/ADuM263N](#)

PHOTOGRAPH OF THE EVALUATION BOARD

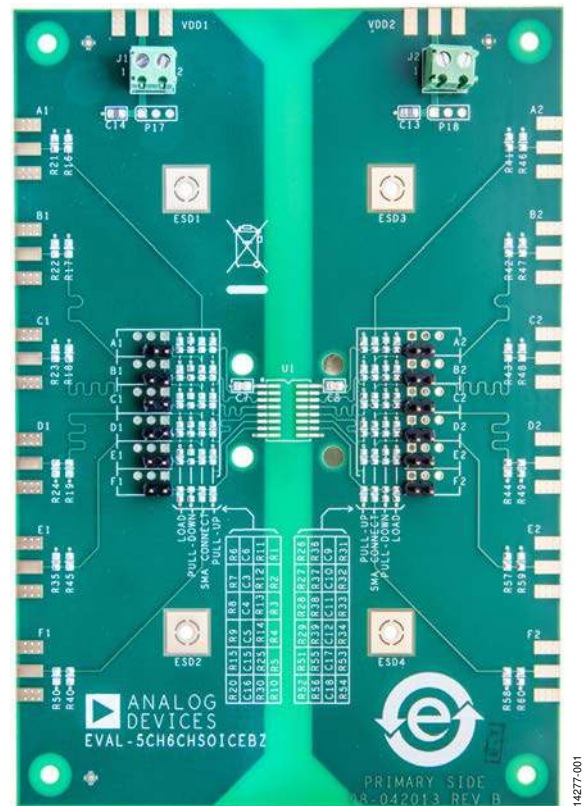

Figure 1.

GENERAL DESCRIPTION

The [EVAL-5CH6CHSOICEBZ](#) supports 5-channel and 6-channel *i*Coupler® standard data isolators in a 16-lead SOIC package. The evaluation board provides a JEDEC standard, 16-lead SOIC_N and SOIC_W pad layout. This layout supports signal distribution, loopback, and loads referenced to the VDDx or GNDx planes, as well as optimal bypass capacitance. Signal sources can be conducted to the evaluation board through header pins or through edge mounted SMA connectors (SMA connectors must be ordered separately). Screw terminal blocks on the evaluation board provide power connections.

The evaluation board includes 0.2 inch header positions for compatibility with active probes (probe header pins must be ordered separately).

The evaluation board follows best PCB design practices for 4-layer boards, including a full power plane and ground plane on each side of the isolation barrier. No other electromagnetic interference (EMI) or noise mitigation design features are included on the evaluation board. In cases of high speed operation, or when ultralow emissions are required, refer to the [AN-1109 Application Note](#) for additional evaluation board layout techniques.

TABLE OF CONTENTS

Features	1	Input Power	3
Supported <i>i</i> Coupler Devices	1	Data Input/Output (I/O) Structures	3
Photograph of the Evaluation Board.....	1	Bypass Capacitance on the PCB.....	4
General Description	1	High Voltage Capability	4
Revision History	2	Evaluation Board Schematics and Artwork	5
Evaluation Board Circuitry	3	Ordering Information.....	8
PCB Evaluation Goals.....	3	Bill of Materials.....	8
Connectors	3		

REVISION HISTORY

10/2016—Rev. 0 to Rev. A

Added ADuM250N/ADuM251N/ADuM252N and ADuM260N/ ADuM261N/ADuM262N/ADuM263N.....	Throughout
Change to General Description	1

9/2016—Rev. 0 to Rev. A

Changes to Features Section, Supported <i>i</i> Coupler Devices Section, and General Description Section	1
Changes to PCB Evaluation Goals Section	3

5/2016—Revision 0: Initial Version

EVALUATION BOARD CIRCUITRY

PCB EVALUATION GOALS

The [EVAL-5CH6CHSOICEBZ](#) achieves the following goals:

- Evaluates the full range of *iCoupler* data transfer functions.
- Independently powers each side of an *iCoupler* isolator.
- Allows high differential voltage to be applied between the two sides of an *iCoupler* isolator. The evaluation board is intended for evaluation of the components, but is not safety certified for high voltage operation. If applying differential voltages above 60 V, external safety measures appropriate for the voltage must be in place.
- Allows easy connection to power supplies, data channels, and instrumentation.

The evaluation board comes installed with power terminals, bypass capacitors, and header pins. The [EVAL-ADuM163N0EBZ](#) is available with the [ADuM163N0](#) device, which is installed on the [EVAL-5CH6CHSOICEBZ](#) evaluation board. All other compatible *iCoupler* digital isolators must be ordered and installed separately on the [EVAL-5CH6CHSOICEBZ](#) evaluation board.

The board is compatible with 5-channel and 6-channel devices, such as the [ADuM150N/ADuM151N/ADuM152N](#), the [ADuM160N/ADuM161N/ADuM162N/ADuM163N](#), the [ADuM250N/ADuM251N/ADuM252N](#), and the [ADuM260N/ADuM261N/ADuM262N/ADuM263N](#).

CONNECTORS

The PCB provides support for three types of interconnections.

- SMA edge mounted connectors
- Through-hole signal ground pairs
- Terminal blocks for power connections

With these three options, temporary and permanent connections to the evaluation board can be made.

When coaxial connections are required, SMA connector positions are available for digital input/output signals and the VDD1/VDD2 power supplies. The SMA connector positions are unpopulated as shipped and must be ordered from a distributor separately. Figure 2 shows examples of installed SMA connectors; these connectors are not only low profile and provide excellent mechanical connections to the PCB, but also support 50 Ω coaxial cabling.

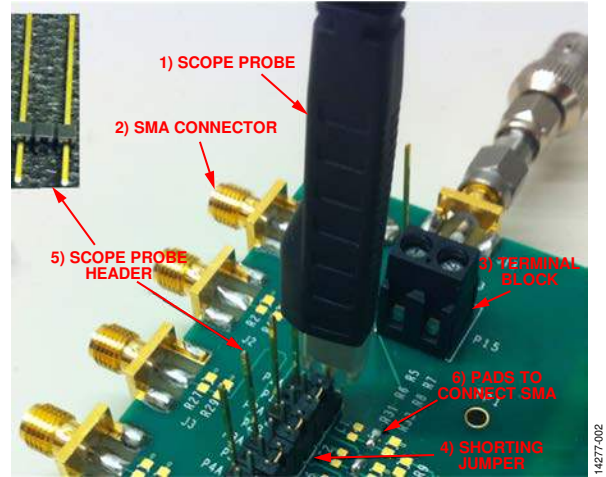

Figure 2. Optional Components

Power can be connected through the J1 and J2 screw terminals or through the optional VDD1 and VDD2 SMA connectors. Signals can be routed in or out with the provided header pins or the optional SMA connectors. The pin spacing of each through-hole connector is 0.1 inch between the centers. There are additional signal test points with 0.2 inch spacing provided for active scope probes. These header pins must be added separately. The installed probe points are shown in Figure 2.

INPUT POWER

Each side of an *iCoupler* standard data isolator requires an off-board power source. On the silkscreen, the J1 and J2 screw terminals are marked 1 for VDDx and 2 for GNDx.

Divided power and ground planes are present on Layer 2 and Layer 3 of the PCB on each side of the isolation barrier. This configuration is shown in Figure 6 and Figure 7, respectively.

DATA INPUT/OUTPUT (I/O) STRUCTURES

Each data channel has a variety of structures to help configure, load, and monitor both the input and output. Figure 3 shows an example of the routing from an external connection to the pin of the device under test (DUT). Each data channel has similar connections.

Starting at the external connection, the signal path is constructed in the following order (see Figure 3 for the locations of these components):

1. A pad layout for a PCB board edge mounted SMA connector.
2. Two 0805 pads are provided where 100 Ω resistors to ground can be installed. The combined resistance is 50 Ω to provide a termination for a standard coaxial cable.
3. A standard 0805 pad layout that allows the coaxial and termination structures to be connected to the rest of the signal path.
4. A 0603 pad layout between the signal path and VDDx for a pull-up resistor, if required.

5. A populated 2-pin header to provide a signal ground pair for use with clip leads or for temporarily shorting a channel to ground.
6. Groupings of three open through holes consisting of a signal and two ground connections. These holes can hardwire signal wires into the PCB, install a header to accept an active probe, or install a 2-pin header to allow adjacent channels to temporarily be shorted together.
7. A 0805 pad layout between the signal and GNDx where a load capacitor or pull-down resistor can be installed.

Figure 2 shows many of the optional components installed, as well as how the jumpers can temporarily connect channels. Figure 2 also shows a signal connected to the first channel SMA, which is then fanned out to the top three channels and monitored by an active scope probe.

BYPASS CAPACITANCE ON THE PCB

Several positions and structures are provided to allow optimal bypass capacitance for the DUT on the evaluation board. Provisions are made for optional surface-mount bulk capacitors to be installed near the power connectors to compensate for long cables to the power supply. Bypass capacitors are installed near the *iCoupler* data isolator and consist of a 0.1 μF capacitor for each DUT VDDx pin on the top side of the evaluation board.

The PCB also implements a distributed capacitive bypass. This bypass consists of power and ground planes closely spaced on the inner layers of the PCB, which reduces noise and the transmission of EMI without using complex design features.

HIGH VOLTAGE CAPABILITY

This PCB is designed in adherence with 2500 V basic insulation practices. High voltage testing beyond 2500 V is not recommended. Do not rely on the evaluation board for safety functions.

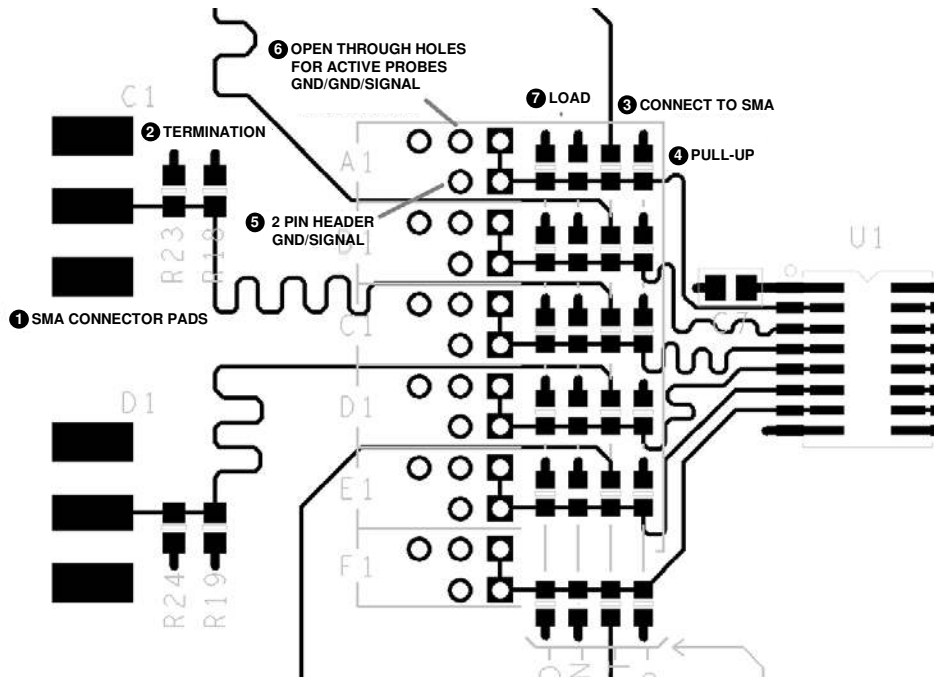

NOTES
 1. THE NUMBERED COMPONENTS IN THIS FIGURE CORRESPOND TO THE DESCRIPTIONS IN THE DATA I/O STRUCTURES SECTION.

Figure 3. Configuration and Monitoring Structures

14277-003

EVALUATION BOARD SCHEMATICS AND ARTWORK

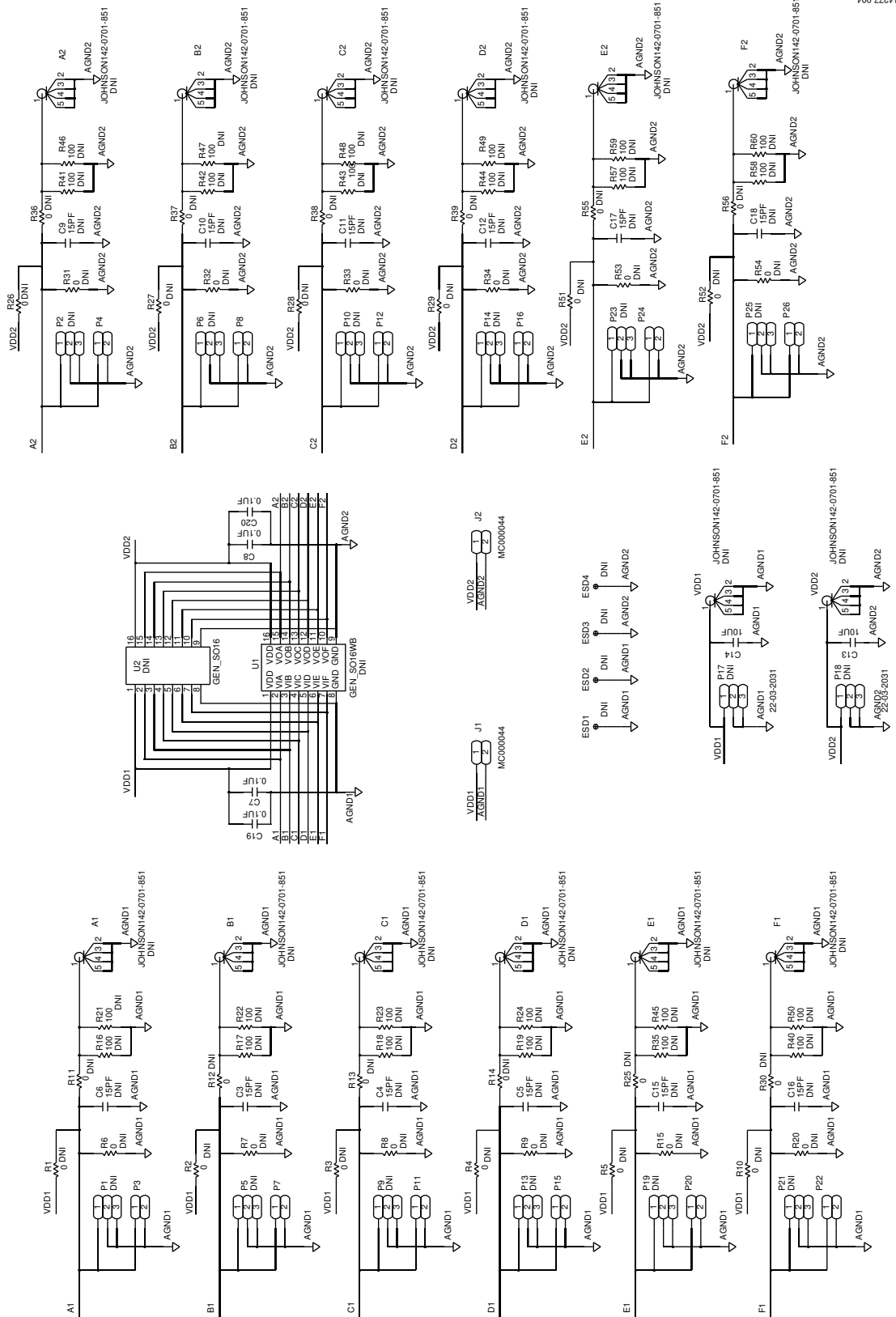

Figure 4. EVAL-5CH6CHSOICEBZ Schematic

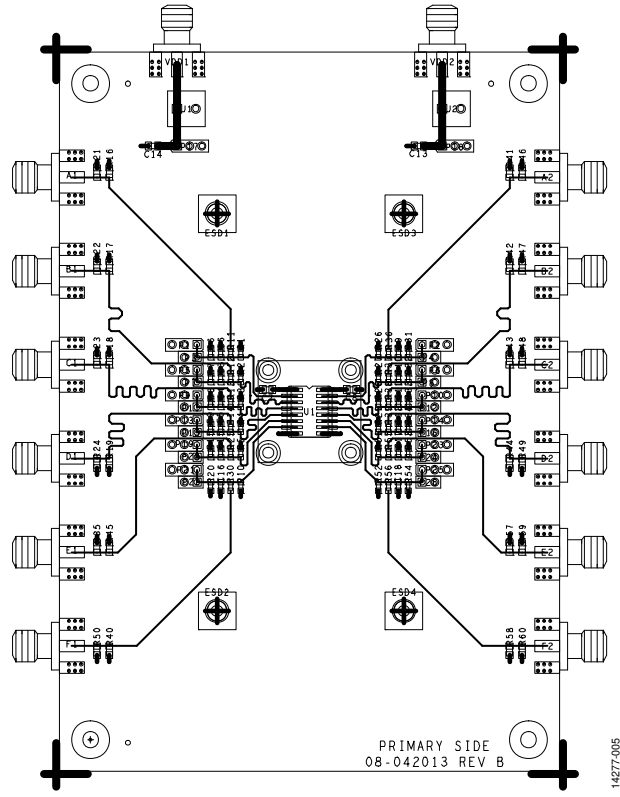

Figure 5. Top Level Signal Routing and Assembly (Layer 1)

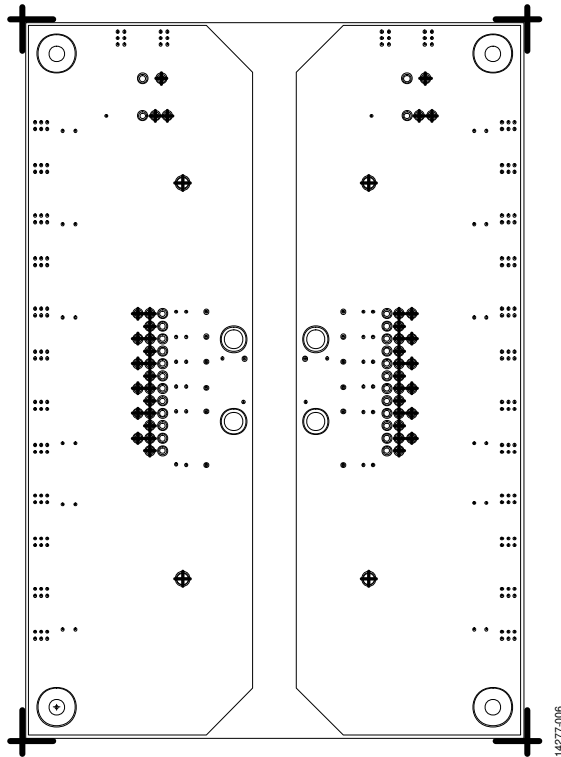

Figure 6. GND1 and GND2 Planes (Layer 2)

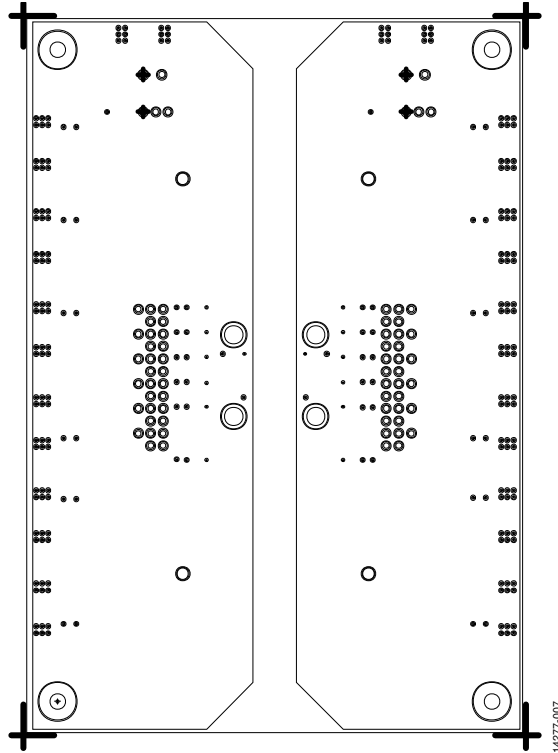

Figure 7. VDD1 and VDD2 Power Plane (Layer 3)

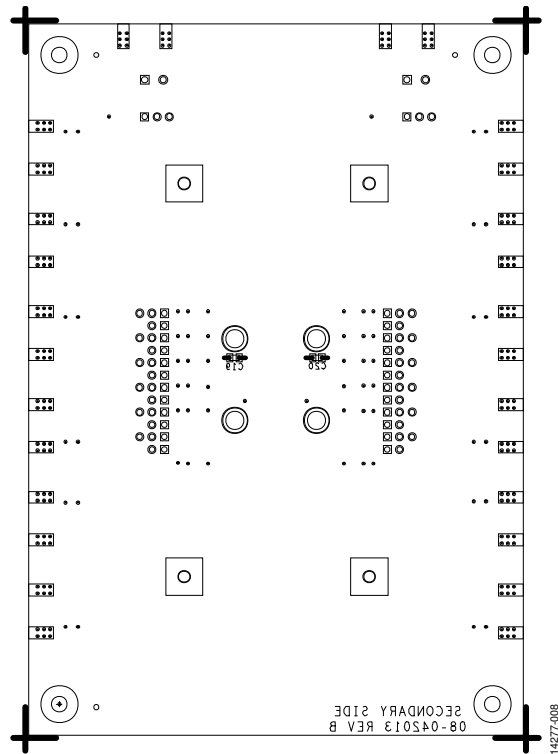

Figure 8. Bottom Layer Assembly and Routing (Layer 4)

ORDERING INFORMATION

BILL OF MATERIALS

Table 1.

Qty	Reference Designator	Description	Manufacturer/Part Number
1	U1	DUT	Analog Devices, Inc./ ADuM163N0BRZ ¹
2	C13, C14	0805, 10 μ F capacitor, CER monolithic	Not applicable
2	C7, C8	0805, 0.1 μ F capacitor, Chip X7R	Not applicable
2	J1, J2	PCB screw terminal	Multicomp/MC000044
12	P3, P4, P7, P8, P11, P12, P15, P16, P20, P22, P24, P26	2-pin header, 100 mil spacing	FCI/69157-102HLF
14	A1, A2, B1, B2, C1, C2, D1, D2, E1, E2, F1, F2, VDD1, VDD2	SMA edge connector (not installed)	Johnson/142-0701-851
14	P1, P2, P5, P6, P9, P10, P13, P14, P17 to P19, P21, P23, P25	2-pin header, 200 mil spacing (not installed)	Not applicable
12	C3 to C6, C9 to C12, C15 to C18	0603, signal load (not installed)	Not applicable
24	R16 to R19, R21 to R24, R35, R40 to R50, R57 to R60	0805, 100 Ω resistors (not installed)	Not applicable
12	R1 to R15, R20, R25 to R34, R36 to R39, R51 to R56	0805, 0 Ω resistors (not installed)	Not applicable

¹ This is the DUT installed on the EVAL-ADuM163N0EBZ; otherwise, this location is unpopulated.



ESD Caution

ESD (electrostatic discharge) sensitive device. Charged devices and circuit boards can discharge without detection. Although this product features patented or proprietary protection circuitry, damage may occur on devices subjected to high energy ESD. Therefore, proper ESD precautions should be taken to avoid performance degradation or loss of functionality.

Legal Terms and Conditions

By using the evaluation board discussed herein (together with any tools, components documentation or support materials, the "Evaluation Board"), you are agreeing to be bound by the terms and conditions set forth below ("Agreement") unless you have purchased the Evaluation Board, in which case the Analog Devices Standard Terms and Conditions of Sale shall govern. Do not use the Evaluation Board until you have read and agreed to the Agreement. Your use of the Evaluation Board shall signify your acceptance of the Agreement. This Agreement is made by and between you ("Customer") and Analog Devices, Inc. ("ADI"), with its principal place of business at One Technology Way, Norwood, MA 02062, USA. Subject to the terms and conditions of the Agreement, ADI hereby grants to Customer a free, limited, personal, temporary, non-exclusive, non-sublicensable, non-transferable license to use the Evaluation Board FOR EVALUATION PURPOSES ONLY. Customer understands and agrees that the Evaluation Board is provided for the sole and exclusive purpose referenced above, and agrees not to use the Evaluation Board for any other purpose. Furthermore, the license granted is expressly made subject to the following additional limitations: Customer shall not (i) rent, lease, display, sell, transfer, assign, sublicense, or distribute the Evaluation Board; and (ii) permit any Third Party to access the Evaluation Board. As used herein, the term "Third Party" includes any entity other than ADI, Customer, their employees, affiliates and in-house consultants. The Evaluation Board is NOT sold to Customer; all rights not expressly granted herein, including ownership of the Evaluation Board, are reserved by ADI. CONFIDENTIALITY. This Agreement and the Evaluation Board shall all be considered the confidential and proprietary information of ADI. Customer may not disclose or transfer any portion of the Evaluation Board to any other party for any reason. Upon discontinuation of use of the Evaluation Board or termination of this Agreement, Customer agrees to promptly return the Evaluation Board to ADI. ADDITIONAL RESTRICTIONS. Customer may not disassemble, decompile or reverse engineer chips on the Evaluation Board. Customer shall inform ADI of any occurred damages or any modifications or alterations it makes to the Evaluation Board, including but not limited to soldering or any other activity that affects the material content of the Evaluation Board. Modifications to the Evaluation Board must comply with applicable law, including but not limited to the RoHS Directive. TERMINATION. ADI may terminate this Agreement at any time upon giving written notice to Customer. Customer agrees to return to ADI the Evaluation Board at that time. LIMITATION OF LIABILITY. THE EVALUATION BOARD PROVIDED HEREUNDER IS PROVIDED "AS IS" AND ADI MAKES NO WARRANTIES OR REPRESENTATIONS OF ANY KIND WITH RESPECT TO IT. ADI SPECIFICALLY DISCLAIMS ANY REPRESENTATIONS, ENDORSEMENTS, GUARANTEES, OR WARRANTIES, EXPRESS OR IMPLIED, RELATED TO THE EVALUATION BOARD INCLUDING, BUT NOT LIMITED TO, THE IMPLIED WARRANTY OF MERCHANTABILITY, TITLE, FITNESS FOR A PARTICULAR PURPOSE OR NON-INFRINGEMENT OF INTELLECTUAL PROPERTY RIGHTS. IN NO EVENT WILL ADI AND ITS LICENSORS BE LIABLE FOR ANY INCIDENTAL, SPECIAL, INDIRECT, OR CONSEQUENTIAL DAMAGES RESULTING FROM CUSTOMER'S POSSESSION OR USE OF THE EVALUATION BOARD, INCLUDING BUT NOT LIMITED TO LOST PROFITS, DELAY COSTS, LABOR COSTS OR LOSS OF GOODWILL. ADI'S TOTAL LIABILITY FROM ANY AND ALL CAUSES SHALL BE LIMITED TO THE AMOUNT OF ONE HUNDRED US DOLLARS (\$100.00). EXPORT. Customer agrees that it will not directly or indirectly export the Evaluation Board to another country, and that it will comply with all applicable United States federal laws and regulations relating to exports. GOVERNING LAW. This Agreement shall be governed by and construed in accordance with the substantive laws of the Commonwealth of Massachusetts (excluding conflict of law rules). Any legal action regarding this Agreement will be heard in the state or federal courts having jurisdiction in Suffolk County, Massachusetts, and Customer hereby submits to the personal jurisdiction and venue of such courts. The United Nations Convention on Contracts for the International Sale of Goods shall not apply to this Agreement and is expressly disclaimed.