

8

7

6

5

4

3

2

1

REVISIONS				
ZONE	REV.	DESCRIPTION	DATE	APPROVED
ALL	A	TABLE REDRAWN ECO 3290	12/10/86	
	B	REMOVED UNUSED P/N#	02/10/09	
	C	ADDED TS209N	03/04/11	
	D	ADDED TS-425	09/13/12	

DETAIL 1

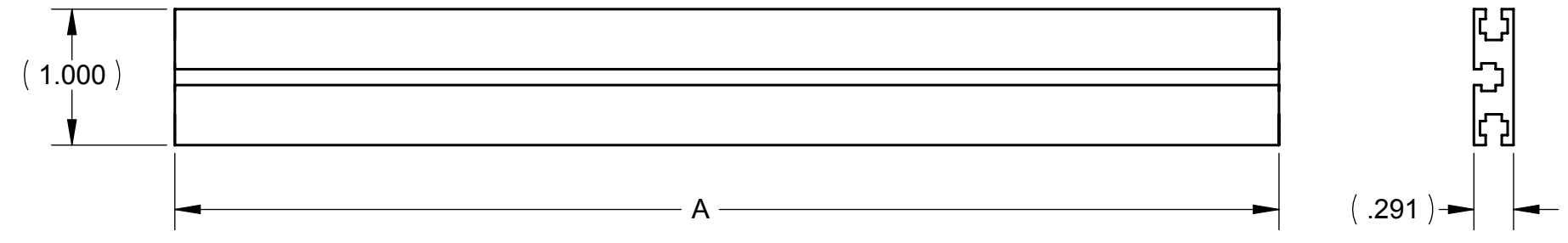

DETAIL 2

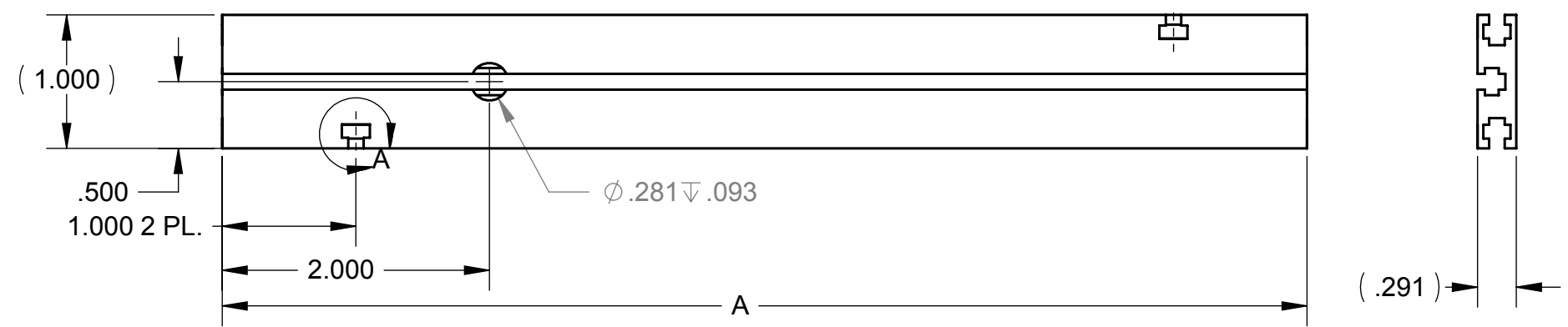

DETAIL 3

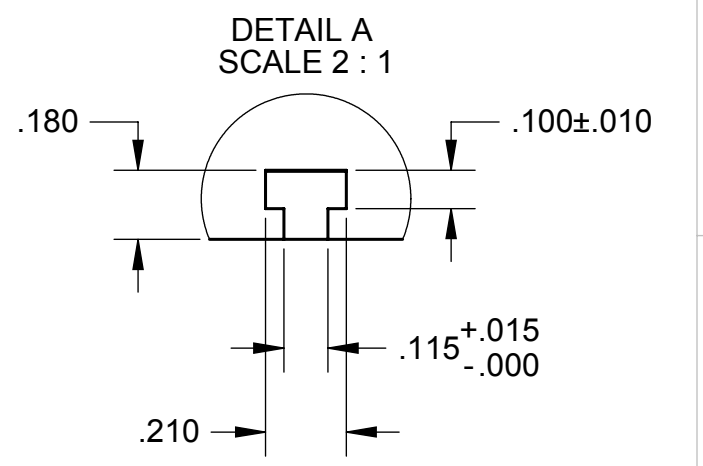
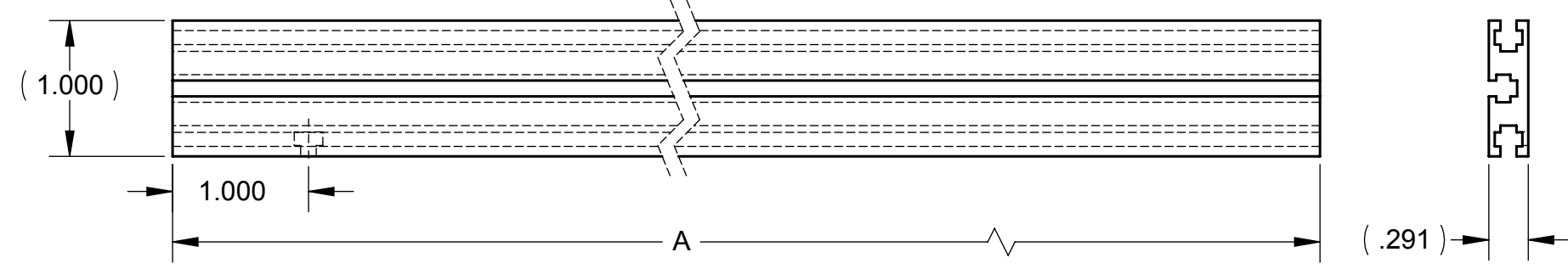

PART NO.	"A" DIM.	DETAIL NO.
TS81	8.120	2
TS169	16.850	2
TS209	20.850	2
TS300	30.00 +1.50/-0.00	1
TS600	60.00 +1.50/-0.00	1
TS169-3	16.850	3
TS209N	20.850	1
TS180	18.000	1
TS190	19.000	2
TS195	19.500	2
TS195-0	19.500	1
TS170	17.000	2
TS-425	4.125	2

- 5. DEGREASE
- 4. STRAIGHT WITHIN .015/10" IN LENGTH
- 3. CUT ENDS TO BE SQUARE WITHIN .0025/INCH IN WIDTH
- 2. REMOVE ALL BURRS
- 1. MAT'L: AL. EXTRUSION, 6063-T6, PRE-ANOD., P/N TS100

NOTES: UNLESS OTHERWISE SPECIFIED.

UNLESS OTHERWISE SPECIFIED:
 DIMENSIONS ARE IN INCHES
 TOLERANCES:
 FRACTIONAL ±
 ANGULAR: ±1°
 TWO PLACE DECIMAL ±.03
 THREE PLACE DECIMAL ±.010
 INTERPRET GEOMETRIC TOLERANCING PER:
 MATERIAL **1**
 FINISH
 DO NOT SCALE DRAWING

PROPRIETARY AND CONFIDENTIAL
 THE INFORMATION CONTAINED IN THIS DRAWING IS THE SOLE PROPERTY OF VECTOR ELECTRONICS & TECH., INC. ANY REPRODUCTION IN PART OR AS A WHOLE WITHOUT THE WRITTEN PERMISSION OF VECTOR ELECTRONICS & TECH., INC. IS PROHIBITED.

	NAME	DATE
DRAWN	TRUSHAR	02/06/09
CHECKED		
ENG APPR.		
MFG APPR.		
Q.A.		

THIRD ANGLE PROJECTION

VECTOR 11115 VANOWEN ST., NORTH HOLLYWOOD, CA 91605
 ELECTRONICS & TECHNOLOGY, INC.

T-STRUT W/O INSERTS

SIZE B	DWG. NO. 5280006	REV D
SCALE: 1:1	WEIGHT:	SHEET 1 OF 1

8

7

6

5

4

3

2

1

INSPECTION REQUIREMENTS	
1	CHECK OVERALL LENGTH
2	CHECK "C" DIMENSION
3	VERIFY .156 DIA. WILL FIT INTO PUNCHED RADII & .160 DIA. WILL NOT FIT INTO PUNCHED RADII
4	CHECK "B" DIMENSION
5	NO CHIPS IN THE BOTTOM OF SLOT

REVISIONS				
ZONE	REV.	DESCRIPTION	DATE	APPROVED
ALL	-	RELEASED FOR PROTOTYPE 100 UNITS OF CCK13S 50 CCM14S & 50 CCK13S	02/14/80	
	A1	P/N TS81-5 NO. OF HOLES WAS 30 ACTUAL STOCK PARTS HAVE 31	07/31/80	
	B	P/N TS81-5 "B" DIM. WAS 7.500 NO. OF HOLES WERE 31/ ECO2013	03/26/81	
	C	MOVED 1.000 DIM. LOCATION CALLOUT FOR CLARITY NO ECO		
	D	ADDED TS81-6 &-7		
	D	INC ECO 2628	12/17/84	
	E	INC ECO 3924		
	F	REMOVED P/N# TS81-6, -7 TS169-5, TS209-5	02/10/09	
	G	ADDED P/N TS169-5/90	02/13/13	

D

C

B

A

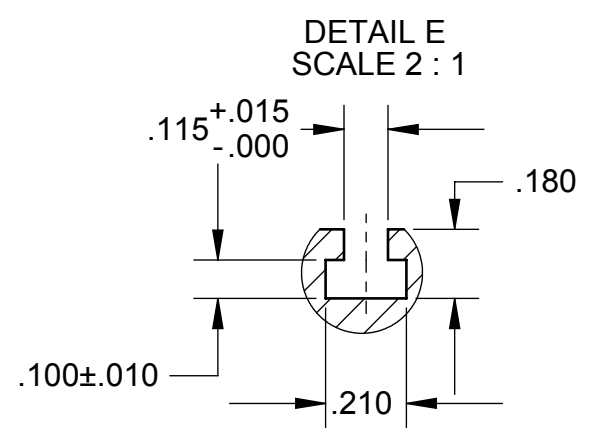
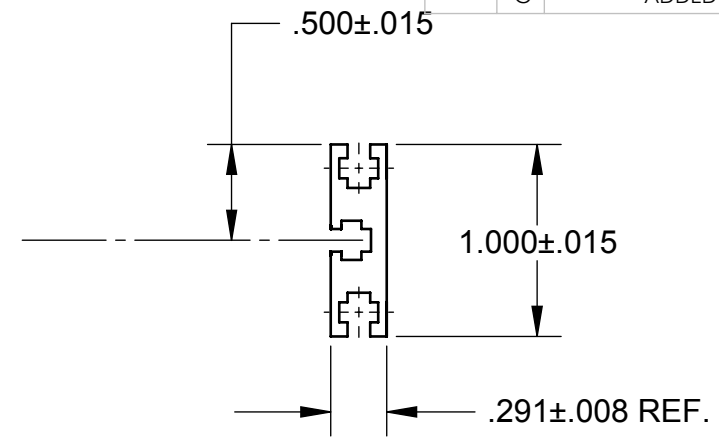
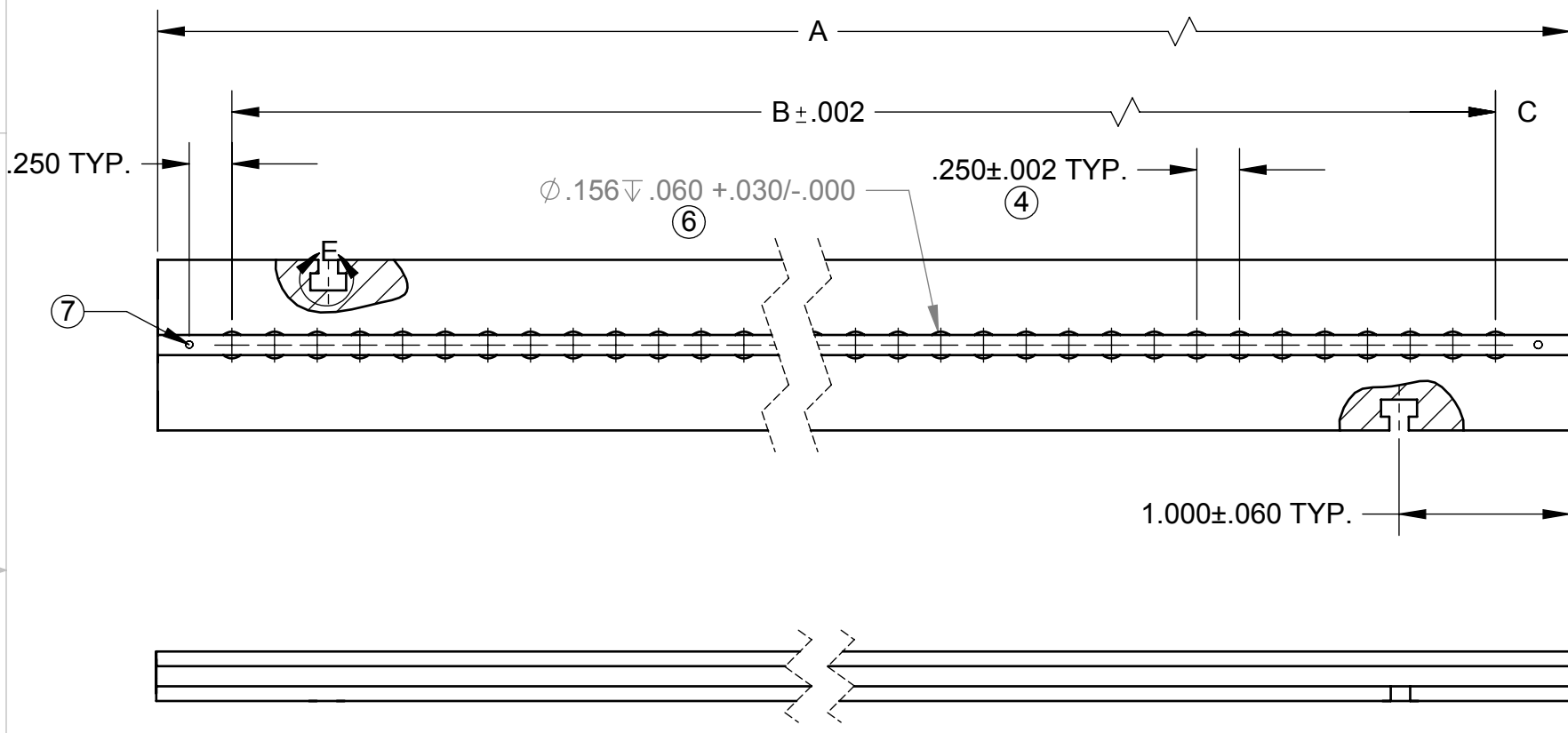

PART NO.	A	B	C	NO. OF HOLES
TS81-5/90	8.120	7.250	.435	30
TS169-6/90	16.850	15.750	.675	64
TS169-5/90	16.850	15.750	.550	64

- ⑦ TOOLING MARK MAY APPEAR
- ⑥ USE .1565 DIA. PUNCH TO FORM RADIUS EQUAL WITHIN ±.005 FROM \bar{C} OF SLOT
- 5. PART TO BE FREE OF BURRS AND SURFACE SCRATCHES
- ④ NON CUMULATIVE TOLERANCE
- 3. PART TO BE STRAIGHT WITHIN .015/10 INCHES IN LENGTH
- 2. CUT ENDS TO BE SQUARE WITHIN .0025/INCH IN WIDTH
- 1. MAT'L: AL. EXTRUSION, 6063-T6, PRE-ANOD., P/N TS100

NOTES: UNLESS OTHERWISE SPECIFIED.

PROPRIETARY AND CONFIDENTIAL
THE INFORMATION CONTAINED IN THIS DRAWING IS THE SOLE PROPERTY OF VECTOR ELECTRONICS & TECH., INC. ANY REPRODUCTION IN PART OR AS A WHOLE WITHOUT THE WRITTEN PERMISSION OF VECTOR ELECTRONICS & TECH., INC. IS PROHIBITED.

UNLESS OTHERWISE SPECIFIED:	NAME	DATE
DIMENSIONS ARE IN INCHES	DRAWN	TRUSHAR
TOLERANCES:	CHECKED	
FRACTIONAL ±	ENG APPR.	
ANGULAR: ± X°	MFG APPR.	
TWO PLACE DECIMAL ±.03	Q.A.	
THREE PLACE DECIMAL ±.005		
INTERPRET GEOMETRIC TOLERANCING PER:		
MATERIAL 1	THIRD ANGLE PROJECTION	
FINISH		
DO NOT SCALE DRAWING		

VECTOR 11115 VANOWEN ST., NORTH HOLLYWOOD, CA 91605

T-STRUT FOR SNAP-IN CARD GUIDE

SIZE	DWG. NO.	REV
B	M6336D4.2	G
SCALE: 1:1	WEIGHT:	SHEET 1 OF 1