

REVISIONS			
LTR	DESCRIPTION	DATE (YR-MO-DA)	APPROVED
A	Add CAGE number 34335 as approved source for 01 device. Add CAGE number 66579 for devices 01 through 04. Add device 04. Delete footnote 4/ from t _{OLQV} condition block. Add footnote 4/ to t _{EHQZ} condition block. Remove test condition C. Make editorial changes to margin test method B. Make editorial changes to power dissipation.	89-08-23	M.A. Frye
B	Add case outline letter and device type 05 for vendor CAGE number 1FN41. Add test condition C to 4.2 and 4.3.2. Add vendor CAGE number 34649 to the drawing as a source for device types 01XX, 02XX, and 03XX. Add vendor CAGE 34335 for devices 04XX, 04YX, 05XX, and 05YX. Removed vendor CAGE number 60991 from drawing. Editorial changes throughout.	93-02-02	M.A. Frye
C	Make changes to paragraph 1.3, Table I, and AC waveforms. Add paragraph 3.11 and remove paragraph 4.2c. Updated boilerplate and Source Approval Bulletin.	96-03-01	M.A. Frye
D	Add device types 06 - 14 to drawing along with CAGE number 65786 as source of supply. Updated boilerplate.	97-07-07	Raymond Monnin

--	--	--	--	--	--	--	--	--	--	--	--	--	--	--	--	--	--

REV																	
SHEET																	
REV	D																
SHEET	15																
REV STATUS OF SHEETS		REV	D	D	D	D	D	D	D	D	D	D	D	D	D	D	D
		SHEET	1	2	3	4	5	6	7	8	9	10	11	12	13	14	

PMIC N/A	PREPARED BY Kenneth Rice		DEFENSE SUPPLY CENTER COLUMBUS COLUMBUS, OHIO 43216-5000														
STANDARD MICROCIRCUIT DRAWING THIS DRAWING IS AVAILABLE FOR USE BY ALL DEPARTMENTS AND AGENCIES OF THE DEPARTMENT OF DEFENSE AMSC N/A	CHECKED BY Ray Monnin																
	APPROVED BY Michael A. Frye																
	DRAWING APPROVAL DATE 88-06-13																
	REVISION LEVEL D																
		SIZE A	CAGE CODE 67268	5962-87648													
		SHEET	1	OF	15												

1. SCOPE

1.1 Scope. This drawing documents two product assurance class levels consisting of high reliability (device classes Q and M) and space application (device class V). A choice of case outlines and lead finishes are available and are reflected in the Part or Identifying Number (PIN). When available, a choice of Radiation Hardness Assurance (RHA) levels are reflected in the PIN.

1.2 PIN. The PIN is as shown in the following examples.

For device class M:

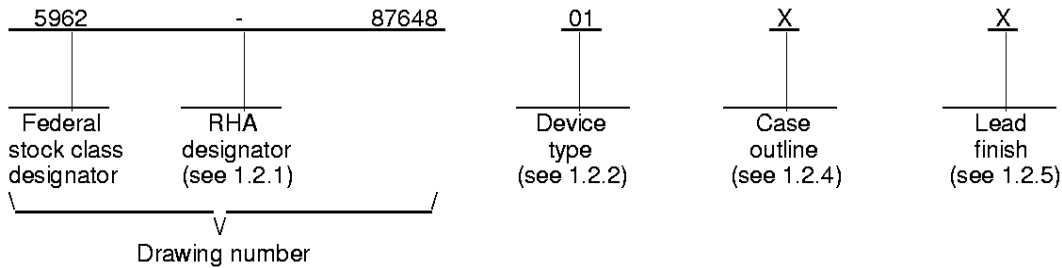

For device classes Q and V:

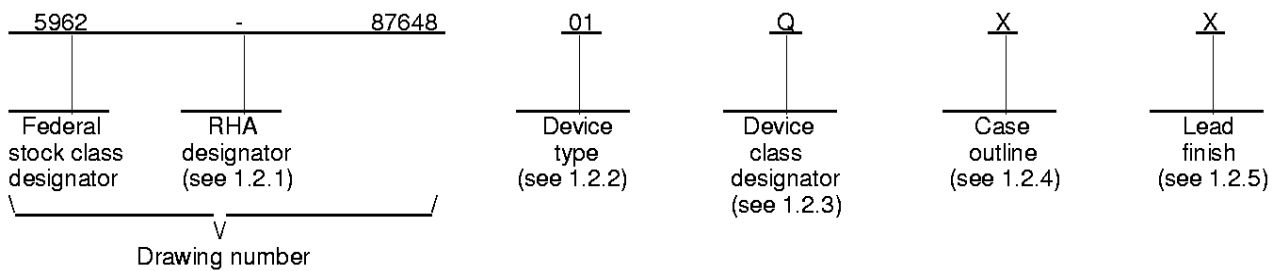

1.2.1 RHA designator. Device classes Q and V RHA marked devices meet the MIL-PRF-38535 specified RHA levels and are marked with the appropriate RHA designator. Device class M RHA marked devices meet the MIL-PRF-38535, appendix A specified RHA levels and are marked with the appropriate RHA designator. A dash (-) indicates a non-RHA device.

1.2.2 Device type(s). The device type(s) shall identify the circuit function as follows:

<u>Device type</u>	<u>Generic number 1/</u>	<u>Circuit function</u>	<u>Access time</u>
01,12		64K x 8-bit UVEPROM	150 ns
02,13		64K x 8-bit UVEPROM	200 ns
03,14		64K x 8-bit UVEPROM	250 ns
04,11		64K x 8-bit UVEPROM	120 ns
05,10		64K x 8-bit UVEPROM	90 ns
06		64K x 8-bit UVEPROM	70 ns
07		64K x 8-bit UVEPROM	55 ns
08		64K x 8-bit UVEPROM	45 ns
09		64K x 8-bit UVEPROM	35 ns

1.2.3 Device class designator. The device class designator is a single letter identifying the product assurance level as listed below. Since the device class designator has been added after the original issuance of this drawing, device class M and Q designators will not be included in the PIN for device types 01 through 05, and will not be marked on the device.

<u>Device class</u>	<u>Device requirements documentation</u>
M	Vendor self-certification to the requirements for MIL-STD-883 compliant, non-JAN class level B microcircuits in accordance with MIL-PRF-38535, appendix A
Q or V	Certification and qualification to MIL-PRF-38535

STANDARD MICROCIRCUIT DRAWING DEFENSE SUPPLY CENTER COLUMBUS COLUMBUS, OHIO 43216-5000	SIZE A		5962-87648
		REVISION LEVEL D	SHEET 2

1.2.4 Case outline(s). The case outline(s) shall be as designated in MIL-STD-1835 and as follows:

<u>Outline letter</u>	<u>Descriptive designator</u>	<u>Terminals</u>	<u>Package style</u>
X	GDIP1-T28 or CDIP2-T28	28	Dual-in-line <u>2/</u>
Y	CQCC1-N32	32	Rectangular leadless chip carrier <u>2/</u>
Z	See figure 1	32	"J" lead chip carrier <u>2/</u>

1.2.5 Lead finish. The lead finish is as specified in MIL-PRF-38535 for device classes Q and V or MIL-PRF-38535, appendix A for device class M.

1.3 Absolute maximum ratings.

Storage temperature range	-65°C to +150°C
Input voltages with respect to ground	-0.6 V dc to +6.25 V dc
Output voltages with respect to ground	-0.6 V dc to $V_{CC} + 1.0$ V dc
Voltage on pin A9 with respect to ground	-0.6 V dc to +13.5 V dc
V_{PP} supply voltage with respect to ground	-0.6 V dc to +14.0 V dc
Power dissipation (P_D) <u>3/</u>	350 mW
Lead temperature (soldering, 10 seconds)	+300°C
Thermal resistance, junction-to-case (Θ_{JC})	See MIL-STD-1835
Junction temperature (T_J)	+150°C

1.4 Recommended operating conditions.

Case operating temperature range (T_C)	-55°C to +125°C
Supply voltage range (V_{CC})	+4.5 V dc to 5.5 V dc

1.5 Digital logic testing for device classes Q and V.

Fault coverage measurement of manufacturing logic tests (MIL-STD-883, test method 5012)	XX percent <u>4/</u>
---	-------	----------------------

1/ Generic numbers listed on the Standard Microcircuit Drawing Source Approval Bulletin at the end of this document and will also be listed in MIL-HDBK-103.

2/ Lid shall be transparent to permit ultraviolet light erasure.

3/ Must withstand the added P_D due to short-circuit test; e.g., I_{OS} .

4/ Values will be added when they become available.

STANDARD MICROCIRCUIT DRAWING DEFENSE SUPPLY CENTER COLUMBUS COLUMBUS, OHIO 43216-5000	SIZE A		5962-87648
		REVISION LEVEL D	SHEET 3

2. APPLICABLE DOCUMENTS

2.1 Government specification, standards, and handbooks. The following specification, standards, and handbooks form a part of this drawing to the extent specified herein. Unless otherwise specified, the issues of these documents are those listed in the issue of the Department of Defense Index of Specifications and Standards (DoDISS) and supplement thereto, cited in the solicitation.

SPECIFICATION

MILITARY

MIL-PRF-38535 - Integrated Circuits, Manufacturing, General Specification for.

STANDARDS

MILITARY

MIL-STD-883 - Test Methods and Procedures for Microelectronics.
 MIL-STD-973 - Configuration Management.
 MIL-STD-1835 - Microcircuit Case Outlines.

HANDBOOKS

MILITARY

MIL-HDBK-103 - List of Standard Microcircuit Drawings (SMD's).
 MIL-HDBK-780 - Standardized Military Drawings.

(Unless otherwise indicated, copies of the specification, standards, and handbooks are available from the Standardization Document Order Desk, 700 Robbins Avenue, Building 4D, Philadelphia, PA 19111-5094.)

2.2 Order of precedence. In the event of a conflict between the text of this drawing and the references cited herein, the text of this drawing takes precedence. Nothing in this document, however, supersedes applicable laws and regulations unless a specific exemption has been obtained.

3. REQUIREMENTS

3.1 Item requirements. The individual item requirements for device classes Q and V shall be in accordance with MIL-PRF-38535 and as specified herein or as modified in the device manufacturer's Quality Management (QM) plan. The modification in the QM plan shall not affect the form, fit, or function as described herein. The individual item requirements for device class M shall be in accordance with MIL-PRF-38535, appendix A for non-JAN class level B devices and as specified herein.

3.2 Design, construction, and physical dimensions. The design, construction, and physical dimensions shall be as specified in MIL-PRF-38535 and herein for device classes Q and V or MIL-PRF-38535, appendix A and herein for device class M.

3.2.1 Case outline(s). The case outline(s) shall be in accordance with 1.2.2 herein and figure 1.

3.2.2 Terminal connections. The terminal connections shall be as specified on figure 2.

3.2.3 Truth table(s). The truth table(s) shall be as specified on figure 3.

3.2.3.1 Unprogrammed or erased devices. The truth table for unprogrammed devices for contracts involving no altered item drawing shall be as specified on figure 2. When required in groups A, B, or C inspection (see 4.3), the devices shall be programmed by the manufacturer prior to test in a checkerboard pattern or equivalent (minimum of 50 percent of the total number of bits programmed) or to any altered item drawing pattern which includes at least 25 percent of the total number of bits programmed.

STANDARD MICROCIRCUIT DRAWING DEFENSE SUPPLY CENTER COLUMBUS COLUMBUS, OHIO 43216-5000	SIZE A		5962-87648
		REVISION LEVEL D	SHEET 4

TABLE I. Electrical performance characteristics.

Test	Symbol	Conditions -55°C ≤ T _C ≤ +125°C; V _{SS} = 0 V; 4.5 V ≤ V _{CC} ≤ 5.5 V unless otherwise specified	Group A subgroups	Device types	Limits		Unit
					Min	Max	
Input leakage current	I _{LI}	V _{IN} = 0 V to 5.5 V	1, 2, 3	All	-10	+10	μA
Output leakage current	I _{LO} 1/	V _{OUT} = 0 V to 5.5 V	1, 2, 3	All	-10	+10	μA
Operating current	I _{CC1}	$\overline{OE} = \overline{OE}/V_{PP} = V_{IL}$, I _{O-7} = 0 mA, V _{CC} = 5.5 V f = 1/t _{AVQV} (maximum)	1, 2, 3	All		60	mA
Standby current (TTL inputs)	I _{CC2}	$\overline{OE} = V_{IH}$, V _{CC} = 5.5 V	1, 2, 3	01 - 05 06 - 14		3 25	mA
Standby current (CMOS inputs)	I _{CC3}	$\overline{OE} = V_{CC} \pm 0.2$ V, V _{CC} = 5.5 V	1, 2, 3	01 - 05 06 - 14		325 25	μA mA
Input low voltage (TTL)	V _{LI} 2/3/		1, 2, 3	All	-0.1	0.8	V
Input low voltage (CMOS)	V _{LI} 2/3/		1, 2, 3	All	-0.2	+0.2	V
Input high voltage (TTL)	V _{HI} 2/3/		1, 2, 3	All	2.0	V _{CC} + 1.0	V
Input high voltage (CMOS)	V _{HI} 2/3/		1, 2, 3	All	V _{CC} - 0.2	V _{CC} + 0.2	V
Output low voltage	V _{OL}	I _{OL} = 2.1 mA, V _{IL} = 0.8 V, V _{IH} = 2.0 V	1, 2, 3	All		0.45	V
Output high voltage	V _{OH}	I _{OH} = -400 μA, V _{IH} = 2.0 V, V _{IL} = 0.8 V	1, 2, 3	All	2.4		V
Output short-circuit	I _{OS}	V _O = 0 V V _O = 0 V 4/	1, 2, 3	01 - 05 06 - 14		±100 ±100	mA
Input capacitance (excluding OE/V _{PP})	C _{IN1} 4/5/	V _{IN} = 0 V, T _C = +25°C, f = 1 MHz, see 4.4.1c	4	All		12	pF
Input capacitance (for OE/V _{PP})	C _{IN2} 4/5/	$\overline{OE}/V_{PP} = 0$, f = 1 MHz, V _{IN} , V _{OUT} = 0 V, T _C = +25°C, see 4.4.1c	4	All		25	pF
Output capacitance	C _{OUT} 4/5/	V _{OUT} = 0 V, T _C = +25°C, f = 1 MHz, see 4.4.1c	4	All		12	pF
Functional tests		See 4.4.1e	7,8A,8B	All			

See footnotes at end of table.

STANDARD MICROCIRCUIT DRAWING DEFENSE SUPPLY CENTER COLUMBUS COLUMBUS, OHIO 43216-5000	SIZE A		5962-87648
		REVISION LEVEL D	SHEET 5

TABLE I. Electrical performance characteristics - Continued.

Test	Symbol	Conditions -55°C ≤ T _C ≤ +125°C; V _{SS} = 0 V; 4.5 V ≤ V _{CC} ≤ 5.5 V unless otherwise specified	Group A subgroups	Device types	Limits		Unit
					Min	Max	
Address to output delay	t _{AVQV}	$\overline{CE} = \overline{OE}/V_{PP} = V_{IL} \text{ 6/ Z/}$	9, 10, 11	01,12		150	ns
				02,13		200	
				03,14		250	
				04,11		120	
				05,10		90	
				06		70	
				07		55	
				08		45	
				09		35	
\overline{CE} to output delay	t _{ELQV}	$\overline{OE}/V_{PP} = V_{IL} \text{ 6/ Z/}$	9, 10, 11	01,12		150	ns
				02,13		200	
				03,14		250	
				04,11		120	
				05,10		90	
				06		70	
				07		55	
				08		45	
				09		35	
\overline{OE} to output delay	t _{OLQV}	$\overline{CE} = V_{IL} \text{ 6/ Z/}$	9, 10, 11	01		70	ns
				02		75	
				03		100	
				04		50	
				05,12		40	
				13,14		60	
				11		35	
				10		30	
				06		25	
				07		20	
				08,09		18	
				\overline{OE} high to output float	t _{EHQZ}	$\overline{CE} = V_{IL} \text{ 4/ 6/ Z/}$	
02		55					
03,13,14		60					
04		45					
05,10		30					
12		40					
11		35					
06		25					
07		20					
08,09		18					
Output hold from address \overline{CE} or \overline{OE}/V_{PP} whichever occurred first	t _{AVQZ}	$\overline{CE} = \overline{OE}/V_{PP} = V_{IL} \text{ 6/ Z/}$	9, 10, 11	All	0		ns

- 1/ Connect all address inputs and \overline{OE} to V_{IH} and measure I_{LO} with the output under test connected to V_{OUT}.
- 2/ Test for all input and control pins.
- 3/ Guaranteed if applied as a forcing function for V_{OL} and V_{OH}.
- 4/ Tested initially and after any design changes that affect this parameter, and therefore shall be guaranteed to the limits specified in table I.
- 5/ All pins not being tested shall be grounded.
- 6/ See figure 5.
- 7/ Equivalent ac test conditions (actual load conditions vary by tester):

Device types 01-06, 10-14:
 Output load = 1 TTL gate and C_L = 100 pF.
 Input rise and fall times ≤ 20 ns.
 Input pulse levels: 0.45 V and 2.4 V.
 Timing measurement reference levels:
 Inputs = 0.8 V and 2.0 V; Outputs = 0.8 V and 2.0 V

Device types 07-09:
 Output load; C_L = 30 pF.
 Input rise and fall times ≤ 3 ns.
 Input pulse levels: 0.0 V and 3.0 V.
 Timing measurement reference levels:
 Inputs = 1.5 V; Outputs = 1.5 V

STANDARD MICROCIRCUIT DRAWING DEFENSE SUPPLY CENTER COLUMBUS COLUMBUS, OHIO 43216-5000	SIZE A		5962-87648
		REVISION LEVEL D	SHEET 6

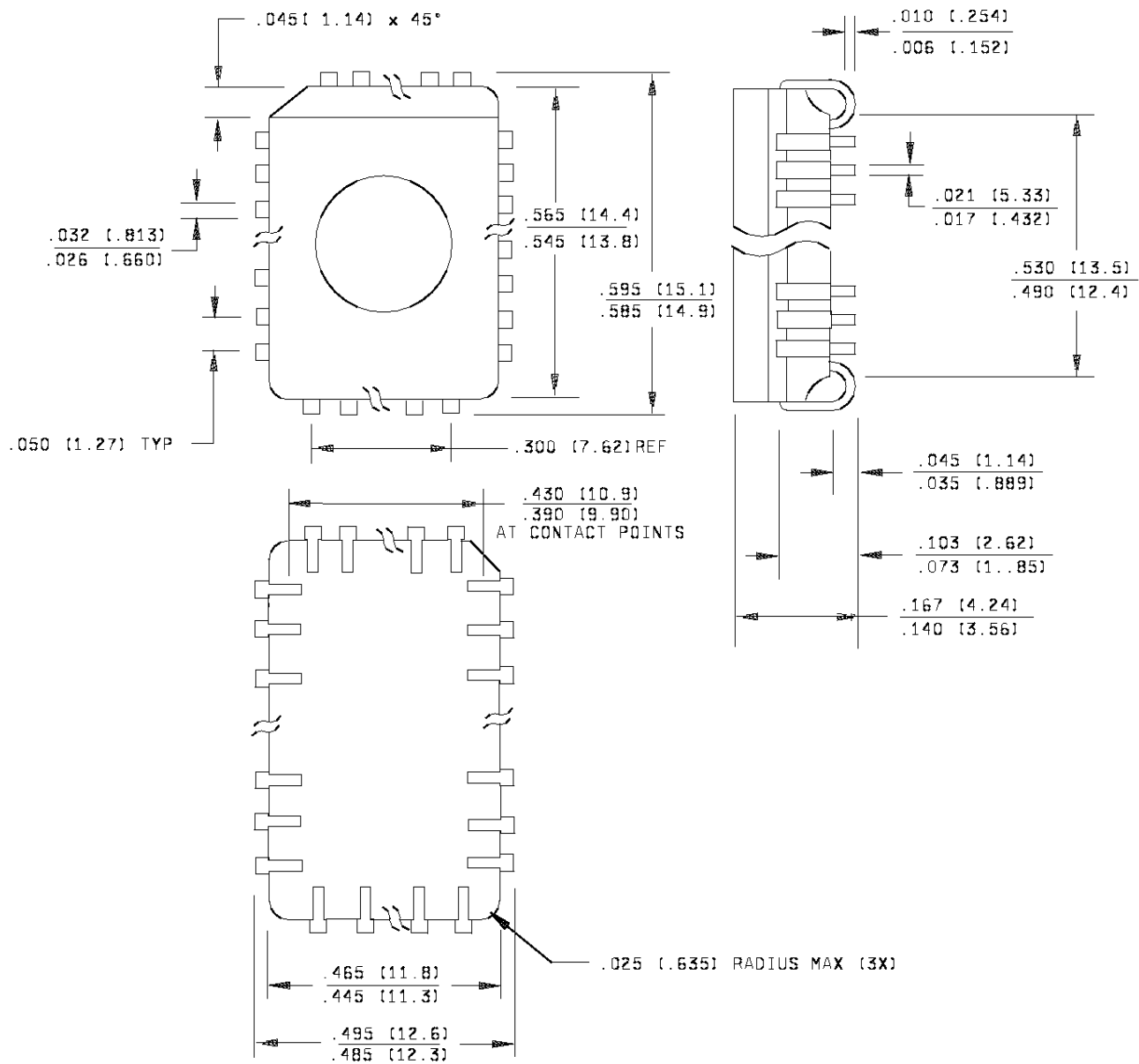

NOTES:

1. Dimensions are in inches.
2. Metric equivalents are given for general information only.
3. Metric equivalents are in parentheses.

FIGURE 1. Case outline Z.

STANDARD MICROCIRCUIT DRAWING DEFENSE SUPPLY CENTER COLUMBUS COLUMBUS, OHIO 43216-5000	SIZE A		5962-87648
		REVISION LEVEL D	SHEET 7

Device types	01 through 14	
Case outlines	X	Y and Z
Terminal number	Terminal symbol	
1	A ₁₅	NC
2	A ₁₂	A ₁₅
3	A ₇	A ₁₂
4	A ₆	A ₇
5	A ₅	A ₆
6	A ₄	A ₅
7	A ₃	A ₄
8	A ₂	A ₃
9	A ₁	A ₂
10	A _Q	A ₁
11	I/O ₀	A _Q
12	I/O ₁	NC
13	I/O ₂	I/O ₀
14	GND	I/O ₁
15	I/O ₃	I/O ₂
16	I/O ₄	GND
17	I/O ₅	NC
18	I/O ₆	I/O ₃
19	I/O ₇	I/O ₄
20	CE	I/O ₅
21	A ₁₀	I/O ₆
22	$\overline{\text{OE}}/V_{PP}$	I/O ₇
23	A ₁₁	CE
24	A ₉	A ₁₀
25	A ₈	$\overline{\text{OE}}/V_{PP}$
26	A ₁₃	NC
27	A ₁₄	A ₁₁
28	V _{CC}	A ₉
29	---	A ₈
30	---	A ₁₃
31	---	A ₁₄
32	---	V _{CC}

FIGURE 2. Terminal connections - Continued.

STANDARD MICROCIRCUIT DRAWING DEFENSE SUPPLY CENTER COLUMBUS COLUMBUS, OHIO 43216-5000	SIZE A		5962-87648
		REVISION LEVEL D	SHEET 8

Mode	Pins				Outputs
	\overline{CE}	\overline{OE}/V_{PP}	A ₉	V _{CC}	
Read	V _{IL}	V _{IL}	X	V _{CC}	D out
Output disable	V _{IL}	V _{IH}	X	V _{CC}	High Z
Standby	V _{IH}	X	X	V _{CC}	High Z
Program	V _{IL}	V _{PP}	X	V _{CC} (see note 1)	D in
Program verify	V _{IL}	V _{IL}	X	V _{CC} (see note 1)	D out
Program inhibit	V _{IH}	V _{PP}	X	V _{CC} (see note 1)	High Z
Identity	V _{IL}	V _{IL}	V _H	V _{CC} (see note 1)	Identity code(s)

NOTES:

1. V_{CC} in programming mode shall be as specified by the device manufacturer.
2. V_H = 11.5 V to 12.5 V.
3. X can be either V_{IL} or V_{IH} (don't care state).

FIGURE 3. Truth table.

STANDARD MICROCIRCUIT DRAWING DEFENSE SUPPLY CENTER COLUMBUS COLUMBUS, OHIO 43216-5000	SIZE A		5962-87648
		REVISION LEVEL D	SHEET 9

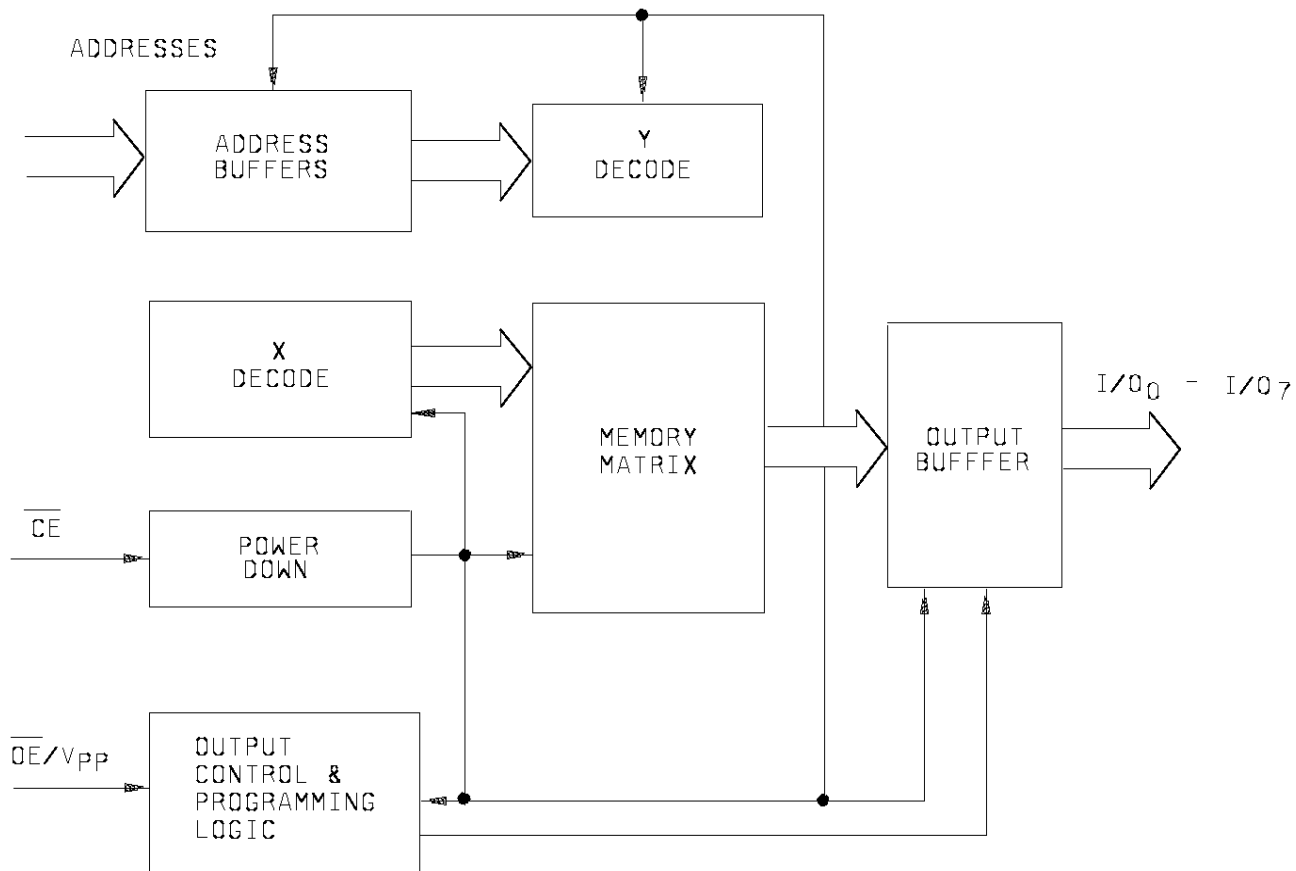
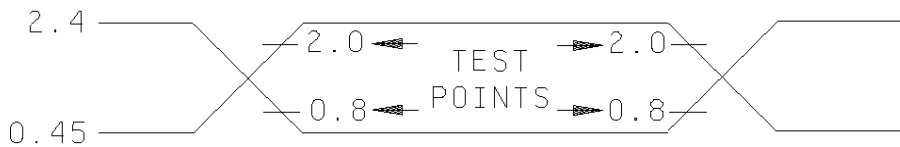

FIGURE 4. Block diagram.

STANDARD MICROCIRCUIT DRAWING DEFENSE SUPPLY CENTER COLUMBUS COLUMBUS, OHIO 43216-5000	SIZE A		5962-87648
		REVISION LEVEL D	SHEET 10

AC testing input, output waveform, device types 01 - 06, 10 - 14



AC testing: See footnote Z/ on sheet 5.

AC testing input, output waveform, device types 07 - 09



AC testing: See footnote Z/ on sheet 5.

AC waveforms

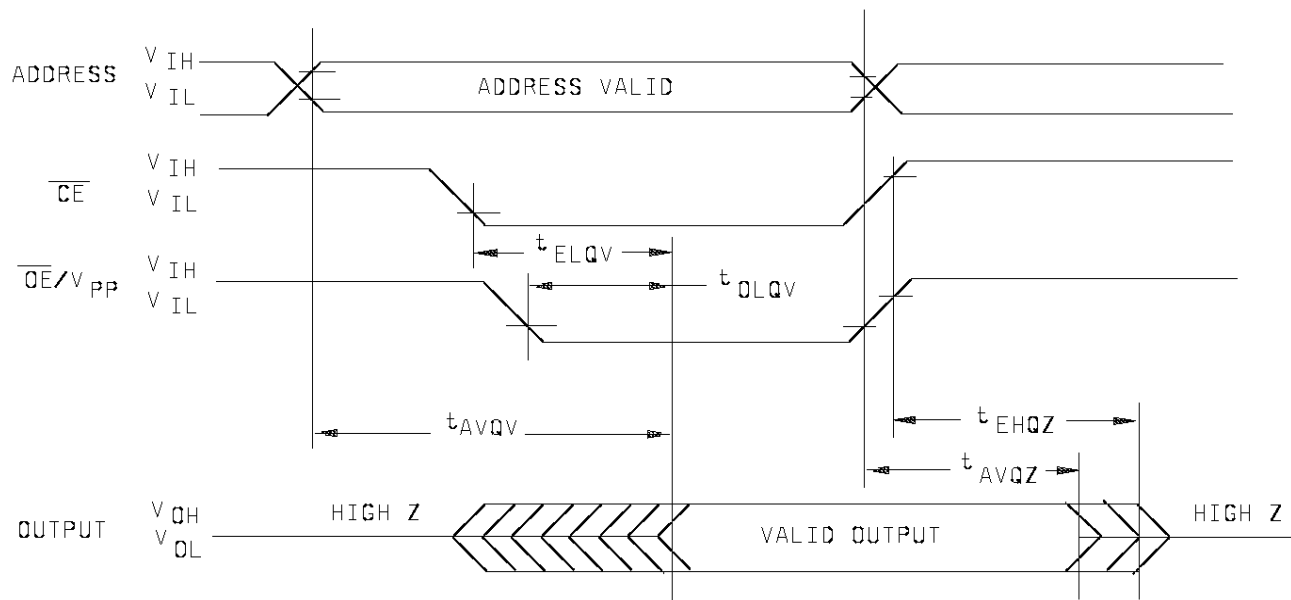

NOTES:

1. t_{EHQZ} and t_{AVQZ} are specified from \overline{OE}/V_{PP} or \overline{CE} , whichever occurs first.
2. \overline{OE}/V_{PP} may be delayed up to $t_{ELQV} - t_{OLQV}$ after the falling edge of \overline{CE} without impact on t_{ELQV} .

FIGURE 5. Switching waveforms.

STANDARD MICROCIRCUIT DRAWING DEFENSE SUPPLY CENTER COLUMBUS COLUMBUS, OHIO 43216-5000	SIZE A		5962-87648
		REVISION LEVEL D	SHEET 11

3.2.3.2 Programmed devices. The truth table for programmed devices shall as specified by an attached altered item drawing.

3.2.4 Block diagram(s). The block diagram(s) shall be as specified on figure 4.

3.3 Electrical performance characteristics and postirradiation parameter limits. Unless otherwise specified herein, the electrical performance characteristics and postirradiation parameter limits are as specified in table I and shall apply over the full case operating temperature range.

3.4 Electrical test requirements. The electrical test requirements shall be the subgroups specified in table IIA. The electrical test for each subgroup are described in table I.

3.5 Marking. The part shall be marked with the PIN listed in 1.2 herein. In addition, the manufacturer's PIN may also be marked as listed in MIL-HDBK-103. For packages where marking of the entire SMD PIN number is not feasible due to space limitations, the manufacturer has the option of not marking the "5962-" on the device. For RHA product using this option, the RHA designator shall still be marked. Marking for device classes Q and V shall be in accordance with MIL-PRF-38535. Marking for device class M shall be in accordance with MIL-PRF-38535, appendix A.

3.5.1 Certification/compliance mark. The certification mark for device classes Q and V shall be a "QML" or "Q" as required in MIL-PRF-38535. The compliance mark for device class M shall be a "C" as required in MIL-PRF-38535, appendix A.

3.6 Certificate of compliance. For device classes Q and V, a certificate of compliance shall be required from a QML-38535 listed manufacturer in order to supply to the requirements of this drawing (see 6.6.1 herein). For device class M, a certificate of compliance shall be required from a manufacturer in order to be listed as an approved source of supply in MIL-HDBK-103 (see 6.6.2 herein). The certificate of compliance submitted to DSCC-VA prior to listing as an approved source of supply for this drawing shall affirm that the manufacturer's product meets, for device classes Q and V, the requirements of MIL-PRF-38535 and herein or for device class M, the requirements of MIL-PRF-38535, appendix A and herein.

3.7 Certificate of conformance. A certificate of conformance as required for device classes Q and V in MIL-PRF-38535 or for device class M in MIL-PRF-38535, appendix A shall be provided with each lot of microcircuits delivered to this drawing.

3.8 Notification of change for device class M. For device class M, notification to DSCC-VA of change of product (see 6.2 herein) involving devices acquired to this drawing is required for any change as defined in MIL-STD-973.

3.9 Verification and review for device class M. For device class M, DSCC, DSCC's agent, and the acquiring activity retain the option to review the manufacturer's facility and applicable required documentation. Offshore documentation shall be made available onshore at the option of the reviewer.

3.10 Microcircuit group assignment for device class M. Device class M devices covered by this drawing shall be in microcircuit group number 42 (see MIL-PRF-38535, appendix A).

3.11 Processing EPROMs. All testing requirements and quality assurance provisions herein shall be satisfied by the manufacturer prior to delivery.

3.11.1 Erasure of EPROMs. When specified, devices shall be erased in accordance with the procedure and characteristics specified in 4.5 herein.

3.11.2 Programmability of EPROMs. When specified, devices shall be programmed to the specified pattern using the procedures and characteristics specified in 4.6 herein.

3.11.3 Verification of erasure and/or programmability of EPROMs. When specified devices shall be verified as either programmed to the specified pattern or erased. As a minimum, verification shall consist of performing a functional test (subgroup 7) to verify that all bits are in the proper state. Any bit that does not verify to be in the proper state shall constitute a device failure, and shall be removed from the lot.

3.12 Data retention. A data retention stress test shall be completed as part of the vendor's reliability monitors. This test shall be done for initial characterization and after any design or process changes which may affect data retention. The methods and procedures may be vendor specific but shall guarantee data retention over the full military temperature range. The vendor's procedure shall be kept under document control and shall be made available upon request of the acquiring or preparing activity, along with test data.

STANDARD MICROCIRCUIT DRAWING DEFENSE SUPPLY CENTER COLUMBUS COLUMBUS, OHIO 43216-5000	SIZE A		5962-87648
		REVISION LEVEL D	SHEET 12

4. QUALITY ASSURANCE PROVISIONS

4.1 Sampling and inspection. For device classes Q and V, sampling and inspection procedures shall be in accordance with MIL-PRF-38535 or as modified in the device manufacturer's Quality Management (QM) plan. The modification in the QM plan shall not affect the form, fit, or function as described herein. For device class M, sampling and inspection procedures shall be in accordance with MIL-PRF-38535, appendix A.

4.2 Screening. For device classes Q and V, screening shall be in accordance with MIL-PRF-38535, and shall be conducted on all devices prior to qualification and technology conformance inspection. For device class M, screening shall be in accordance with method 5004 of MIL-STD-883, and shall be conducted on all devices prior to quality conformance inspection.

4.2.1 Additional criteria for device class M.

- a. Burn-in test, method 1015 of MIL-STD-883.
 - (1) Test condition C or D. The test circuit shall be maintained by the manufacturer under document revision level control and shall be made available to the preparing or acquiring activity upon request. The test circuit shall specify the inputs, outputs, biases, and power dissipation, as applicable, in accordance with the intent specified in test method 1015 of MIL-STD-883.
 - (2) $T_A = +125^\circ\text{C}$, minimum.
- b. Interim and final electrical test parameters shall be as specified in table IIA herein.

4.2.2 Additional criteria for device classes Q and V.

- a. The burn-in test duration, test condition and test temperature, or approved alternatives shall be as specified in the device manufacturer's QM plan in accordance with MIL-PRF-38535. The burn-in test circuit shall be maintained under document revision level control of the device manufacturer's Technology Review Board (TRB) in accordance with MIL-PRF-38535 and shall be made available to the acquiring or preparing activity upon request. The test circuit shall specify the inputs, outputs, biases, and power dissipation, as applicable, in accordance with the intent specified in test method 1015 of MIL-STD-883.
- b. Interim and final electrical test parameters shall be as specified in table IIA herein.
- c. Additional screening for device class V beyond the requirements of device class Q shall be as specified in MIL-PRF-38535, appendix B.

4.3 Qualification inspection for device classes Q and V. Qualification inspection for device classes Q and V shall be in accordance with MIL-PRF-38535. Inspections to be performed shall be those specified in MIL-PRF-38535 and herein for groups A, B, C, D, and E inspections (see 4.4.1 through 4.4.4).

4.4 Conformance inspection. Technology conformance inspection for classes Q and V shall be in accordance with MIL-PRF-38535 including groups A, B, C, D, and E inspections and as specified herein except where option 2 of MIL-PRF-38535 permits alternate in-line control testing. Quality conformance inspection for device class M shall be in accordance with MIL-PRF-38535, appendix A and as specified herein. Inspections to be performed for device class M shall be those specified in method 5005 of MIL-STD-883 and herein for groups A, B, C, D, and E inspections (see 4.4.1 through 4.4.4)

4.4.1 Group A inspection.

- a. Tests shall be as specified in table IIA herein.
- b. Subgroups 5 and 6 in table I, method 5005 of MIL-STD-883 shall be omitted.
- c. Subgroup 4 (C_{IN} and C_{OUT} measurements) shall be measured for the initial characterization and after any process or design changes which may affect capacitance. Sample size is 15 devices with no failures, and all input and output terminals tested.
- d. All devices selected for testing shall have the EPROM programmed with a checkerboard pattern or equivalent. After completion of all testing, the devices shall be erased and verified (except devices submitted for groups C and D testing).
- e. Subgroups 7 and 8 shall consist of verifying the EPROM pattern specified in 4.4.1d.

STANDARD MICROCIRCUIT DRAWING DEFENSE SUPPLY CENTER COLUMBUS COLUMBUS, OHIO 43216-5000	SIZE A		5962-87648
		REVISION LEVEL D	SHEET 13

TABLE IIA. Electrical test requirements. 1/ 2/ 3/ 4/

Line no.	Test requirements	Subgroups (in accordance with MIL-STD-883, TM 5005 Table I)		
		Subgroups (in accordance with MIL-PRF-38535, table III)	Device class M	Device class Q
1	Interim electrical parameters (see 4.2)			1, 7, 9
2	Static burn-in (method 1015)	Not required	Not required	Required
3	Same as line 1			1*, 7* Δ
4	Dynamic burn-in (method 1015)	Required	Required	Required
5	Same as line 1			1*, 7* Δ
6	Final electrical parameters (see 4.2)	1*, 2, 3, 7*, 8A, 8B, 9	1*, 2, 3, 7*, 8A, 8B, 9	1*, 2, 3, 7*, 8A, 8B, 9, 10, 11
7	Group A test requirements (see 4.4)	1, 2, 3, 4***, 7, 8A, 8B, 9, 10**, 11**	1, 2, 3, 4***, 7, 8A, 8B, 9, 10**, 11**	1, 2, 3, 4***, 7, 8A, 8B, 9, 10**, 11**
8	Group C end-point electrical parameters (see 4.4)	2, 8A, 10	2, 8A, 10	1, 2, 3, 7, 8A, 8B, 9, 10, 11 Δ
9	Group D end-point electrical parameters (see 4.4)	2, 8A, 10	2, 8A, 10	2, 3, 8A, 8B
10	Group E end-point electrical parameters (see 4.4)	1, 7, 9	1, 7, 9	1, 7, 9

1/ (*) indicates PDA applies to subgroups 1 and 7.

2/ (**) indicates that subgroups 10 and 11, if not tested, shall be guaranteed to the specified limits in table I.

3/ (***) see 4.4.1c.

4/ Any subgroups at the same temperature may be combined when using a multifunction tester.

5/ Subgroups 7 and 8 shall consist of verifying the applicable data pattern, see 4.4.1d.

6/ Δ indicates delta limit (see table IIB) shall be required where specified, and the delta values shall be computed with reference to the previous interim electrical parameters (see line 1).

4.4.2 Group C inspection. The group C inspection end-point electrical parameters shall be as specified in table IIA herein.

4.4.2.1 Additional criteria for device class M. Steady-state life test conditions, method 1005 of MIL-STD-883:

- a. Test conditions C and D. The test circuit shall be maintained by the manufacturer under document revision level control and shall be made available to the preparing or acquiring activity upon request. The test circuit shall specify the inputs, outputs, biases, and power dissipation, as applicable, in accordance with the intent specified in test method 1005 of MIL-STD-883.
- b. $T_A = +125^\circ\text{C}$, minimum.
- c. Test duration: 1,000 hours, except as permitted by method 1005 of MIL-STD-883.
- d. All devices selected for testing shall be programmed with a checkerboard pattern or equivalent. After completion of all testing, those devices that were subjected to a nondestructive subgroup for testing shall be erased and verified.

4.4.2.2 Additional criteria for device classes Q and V. The steady-state life test duration, test condition and test temperature, or approved alternatives shall be as specified in the device manufacturer's QM plan in accordance with MIL-PRF-38535. The test circuit shall be maintained under document revision level control by the device manufacturer's TRB in accordance with MIL-PRF-38535 and shall be made available to the acquiring or preparing activity upon request. The test circuit shall specify the inputs, outputs, biases, and power dissipation, as applicable, in accordance with the intent specified in test method 1005 of MIL-STD-883.

4.4.3 Group D inspection. The group D inspection end-point electrical parameters shall be as specified in table IIA herein.

STANDARD MICROCIRCUIT DRAWING DEFENSE SUPPLY CENTER COLUMBUS COLUMBUS, OHIO 43216-5000	SIZE A		5962-87648
		REVISION LEVEL D	SHEET 14

TABLE IIB. Delta limits at +25° C.

Parameter <u>1/</u>	Device types
I _{CC3}	All
I _{L1}	± 10%
I _{L0}	± 10%

1/ The above parameter shall be recorded before and after the required burn-in and life tests to determine the delta.

4.4.4 Group E inspection. Group E inspection is required only for parts intended to be marked as radiation hardness assured (see 3.5 herein).

- a. End-point electrical parameters shall be as specified in table IIA herein.
- b. For device classes Q and V, the devices or test vehicle shall be subjected to radiation hardness assured tests as specified in MIL-PRF-38535 for the RHA level being tested. For device class M, the devices shall be subjected to radiation hardness assured tests as specified in MIL-PRF-38535, appendix A for the RHA level being tested. All device classes must meet the postirradiation end-point electrical parameter limits as defined in table I at T_A = +25° C ±5° C, after exposure, to the subgroups specified in table IIA herein.
- c. When specified in the purchase order or contract, a copy of the RHA delta limits shall be supplied.

4.5 Erasing procedure. The recommended erasure procedure for the device is exposure to shortwave ultraviolet light which has a wavelength of 2537 Angstroms (Å). The integrated dose (i.e., UV intensity x exposure time) for exposure should be a minimum of 15 Ws/cm². The erasure time with this dosage is approximately 25 minutes using an ultraviolet lamp with a 12000 μW/cm² power rating. The device should be placed within 1 inch of the lamp tubes during erasure. The maximum integrated dose the device can be exposed to without damage is 7258 Ws/cm² (1 week at 12000 μW/cm²). Exposure of EPROMs to high intensity UV light for long periods may cause permanent damage.

4.6 Programming procedures. The programming procedures shall be as specified by the device manufacturer.

5. PACKAGING

5.1 Packaging requirements. The requirements for packaging shall be in accordance with MIL-PRF-38535, appendix A.

6. NOTES

6.1 Intended use. Microcircuits conforming to this drawing are intended for use for Government microcircuit applications (original equipment), design applications, and logistics purposes.

6.1.1 Replaceability. Microcircuits covered by this drawing will replace the same generic device covered by a contractor-prepared specification or drawing.

6.2 Configuration control of SMD's. All proposed changes to existing SMD's will be coordinated with the users of record for the individual documents. This coordination will be accomplished in accordance with MIL-STD-973 using DD Form 1692, Engineering Change Proposal.

6.3 Record of users. Military and industrial users should inform Defense Supply Center Columbus when a system application requires configuration control and which SMD's are applicable to that system. DSCC will maintain a record of users and this list will be used for coordination and distribution of changes to the drawings. Users of drawings covering microelectronic devices (FSC 5962) should contact DSCC-VA, telephone (614) 692-0525.

6.4 Comments. Comments on this drawing should be directed to DSCC-VA, Columbus, Ohio 43216-5000, or telephone (614) 692-0674.

6.5 Abbreviations, symbols, and definitions. The abbreviations, symbols, and definitions used herein are defined in MIL-PRF-38535 and MIL-HDBK-1331.

6.6 Sources of supply.

6.6.1 Sources of supply for device classes Q and V. Sources of supply for device classes Q and V are listed in QML-38535. The vendors listed in QML-38535 have submitted a certificate of compliance (see 3.6 herein) to DSCC-VA and have agreed to this drawing.

6.6.2 Approved sources of supply for device class M. Approved sources of supply for class M are listed in MIL-HDBK-103. The vendors listed in MIL-HDBK-103 have agreed to this drawing and a certificate of compliance (see 3.6 herein) has been submitted to and accepted by DSCC-VA.

STANDARD MICROCIRCUIT DRAWING DEFENSE SUPPLY CENTER COLUMBUS COLUMBUS, OHIO 43216-5000	SIZE A		5962-87648
		REVISION LEVEL D	SHEET 15

STANDARD MICROCIRCUIT DRAWING SOURCE APPROVAL BULLETIN

DATE: 97-07-07

Approved sources of supply for SMD 5962-87648 are listed below for immediate acquisition only and shall be added to MIL-HDBK-103 and QML-38535, as applicable, during the next revision. MIL-HDBK-103 and QML-38535 will be revised to include the addition or deletion of sources. The vendors listed below have agreed to this drawing and a certificate of compliance has been submitted to and accepted by DSCC-VA. This bulletin is superseded by the next dated revision of MIL-HDBK-103 and QML-38535.

Standard microcircuit drawing PIN <u>1</u> /	Vendor CAGE number	Vendor similar PIN <u>3</u> /	Replacement military specification PIN
5962-8764801XA	<u>2</u> / <u>2</u> / 34649 <u>4</u> / <u>2</u> /	AT27C512R-15DM/883 AM27C512-150/BXA MD27C512-15/B WS27C512L-15DMB	
5962-8764801YX	<u>2</u> / <u>2</u> / <u>2</u> /	AT27C512R-15LM/883 AM27C512-150/BUA WS27C512L-15CMB	
5962-8764801ZX	<u>2</u> /	AT27C512R-15KM/883	
5962-8764802XA	01295 <u>2</u> / <u>2</u> / 34649 <u>4</u> / <u>2</u> /	SMJ27C512-20JM AT27C512R-20DM/883 AM27C512-200/BXA MD27C512-20/B WS27C512L-20DMB	
5962-8764802YX	<u>2</u> / <u>2</u> / <u>2</u> /	AT27C512R-20LM/883 AM27C512-200/BUA WS27C512L-20CMB	
5962-8764802ZX	<u>2</u> /	AT27C512R-20KLM/883	
5962-8764803XA	01295 <u>2</u> / <u>2</u> / 34649 <u>4</u> / <u>2</u> /	SMJ27C512-25JM AT27C512R-25DM/883 AM27C512-250/BXA MD27C512-25/B WS27C512L-25DMB	
5962-8764803YX	<u>2</u> / <u>2</u> / <u>2</u> /	AT27C512R-25LM/883 AM27C512-250/BUA WS27C512L-25CMB	
5962-8764803ZX	<u>2</u> /	AT27C512R-25KM/883	
5962-8764804XX	<u>2</u> / <u>2</u> / <u>2</u> /	AT27C512R-12DM/883 WS27C512L-12DMB AM27C512-120/BXA	
5962-8764804YX	<u>2</u> / <u>2</u> / <u>2</u> /	AT27C512R-12LM/883 WS27C512L-12CMB AM27C512-120/BUA	
5962-8764804ZX	<u>2</u> /	AT27C512R-12KM/883	
5962-8764805XX	<u>2</u> / <u>2</u> /	AT27C512R-90DM/883 AM27C512-90/BXA	
5962-8764805YX	<u>2</u> / <u>2</u> /	AT27C512R-90LM/883 AM27C512-90/BUA	
5962-8764805ZX	<u>2</u> /	AT27C512R-90KM/883	
5962-8764806QXA	65786	CY27C512-70WMB	
5962-8764806QYA	65786	CY27C512-70QMB	
5962-8764807QXA	65786	CY27C512-55WMB	
5962-8764807QYA	65786	CY27C512-55QMB	
5962-8764808QXA	65786	CY27C512-45WMB	
5962-8764808QYA	65786	CY27C512-45QMB	

See footnotes at end of table.

STANDARD MICROCIRCUIT DRAWING SOURCE APPROVAL BULLETIN - Continued

5962-8764809QXA	65786	CY27H512-35WMB	
5962-8764809QYA	65786	CY27H512-35QMB	
5962-8764810QXA	65786	CY27C512-90WMB	
5962-8764810QYA	65786	CY27C512-90QMB	
5962-8764811QXA	65786	CY27C512-120WMB	
5962-8764811QYA	65786	CY27C512-120QMB	
5962-8764812QXA	65786	CY27C512-150WMB	
5962-8764812QYA	65786	CY27C512-150QMB	
5962-8764813QXA	65786	CY27C512-200WMB	
5962-8764813QYA	65786	CY27C512-200QMB	
5962-8764814QXA	65786	CY27C512-250WMB	
5962-8764814QYA	65786	CY27C512-250QMB	

- 1/ The lead finish shown for each PIN representing a hermetic package is the most readily available from the manufacturer listed for that part. The device manufacturers listed herein are authorized to supply alternate lead finishes "A", "B", or "C" at their discretion. Contact the listed approved source of supply for further information.
- 2/ No longer available from an approved source of supply.
- 3/ Caution: Do not use this number for item acquisition. Items acquired to this number may not satisfy the performance requirements of this drawing.
- 4/ Vendor has announced end-of-life for these devices. Please refer to the latest revision of MIL-HDBK-103 or QML-38535, as applicable, for details.

<u>Vendor CAGE number</u>	<u>Vendor name and address</u>
01295	Texas Instruments P. O. Box 6448 Midland, TX 79711
34649	Intel Corporation 3065 Bowers Avenue Santa Clara, CA 95051 Point of contact: 5000 W. Chandler Boulevard Chandler, AZ 85226
65786	Cypress Semiconductor 3901 North First Street San Jose, CA 95134-1599

The information contained herein is disseminated for convenience only and the Government assumes no liability whatsoever for any inaccuracies in this information bulletin.