

LOC	DIST	REVISIONS			
REV	DATE	DESCRIPTION	DATE	BY	APPV
AJ	16				
AZ1		REVISED PER ECO-11-005030	11MAR11	RK	HMR

- 1 BRASS PER QQ-B-626.
 - 2 BERYLLIUM COPPER PER ASTM-B-196
 - 3 NYLON PER ASTM-D-4066, BLACK
 - 4 POLYMETHYLPENTENE GENERAL PURPOSE, NATURAL
 - 5 .000030 MINIMUM GOLD PER MIL-G-45204.
 - 6 .000050 MINIMUM GOLD PER MIL-G-45204.
 - 7 .000100 MINIMUM GOLD PER MIL-G-45204.
 - 8 RG-174/U, RG-179A/U, RG-187/U, AND 21-598.
 - 9 SHIELDED CABLE #26=NAS-702 CLASS A & C, AND MIL-W-16878 TYPES E & EE, SHIELDED CABLE #24=NAS-702 CLASS A & C, AND MIL-W-16878 TYPES E & EE, SHIELDED CABLE #22=NAS-702 CLASS C, AND MIL-W-16878 TYPE E, AND MIL-C-7078A TYPE I NUMBER 1 DIELECTRIC .068 O.D.
10. SEE IS 408-1770
- 12 NYLON PER ASTM-D-4066, NATURAL
 - 13 DIELECTRIC MATERIAL: VALOX 325 WHITE

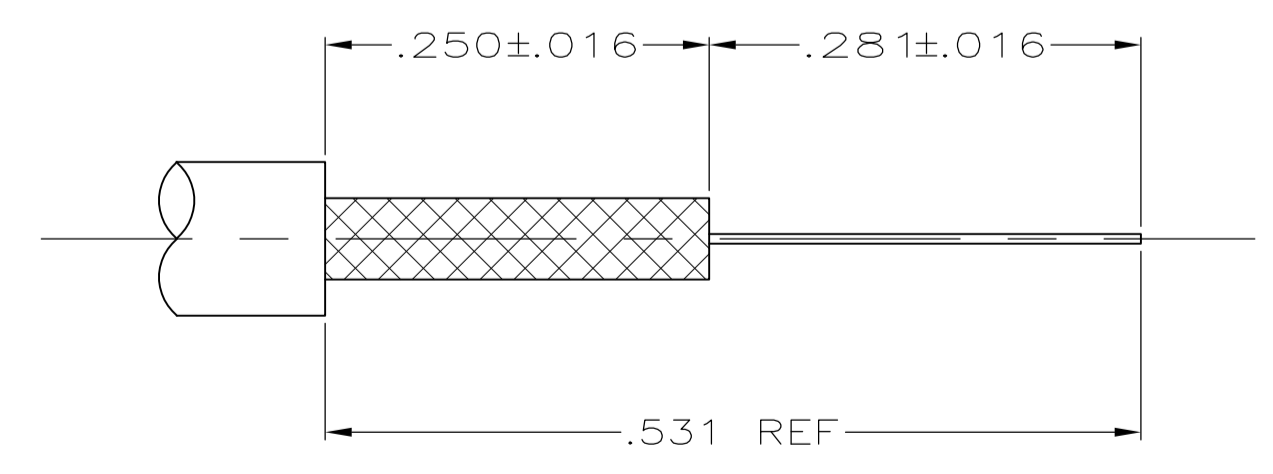
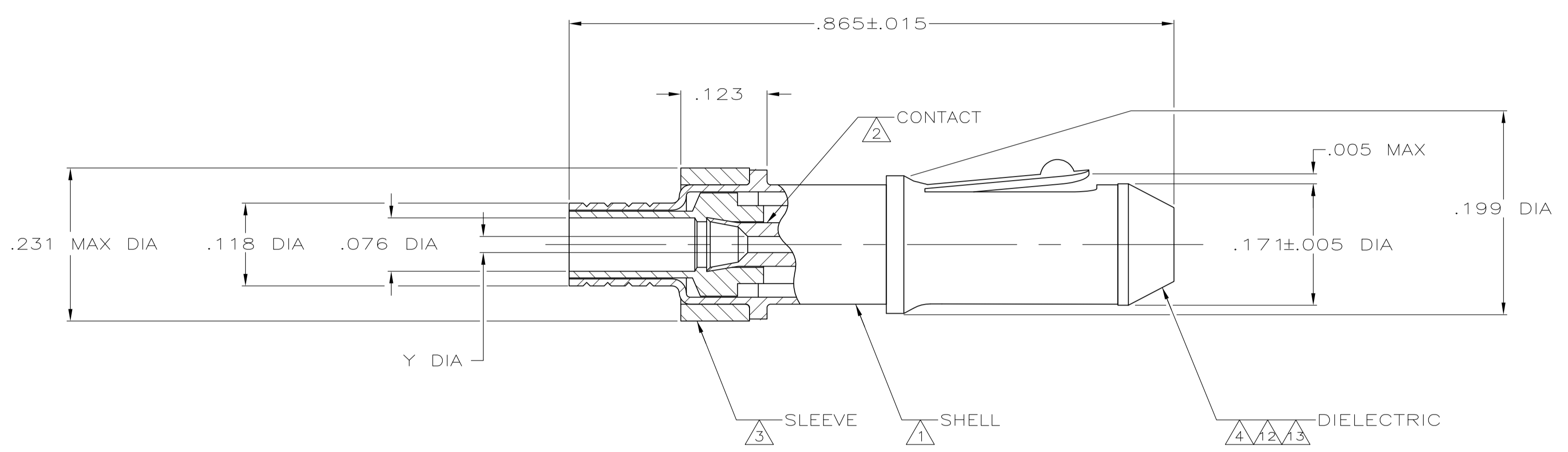

VIEW D
RECOMMENDED STRIP LENGTH

13	5	5	.030 OUNCES	-	-	.032±.003	-	-	-	2-201143-5
13	5	5	.030 OUNCES	-	-	.032±.003	-	-	-	2-201143-4
	7	7	.030 OUNCES	-	-	.032±.003	-	-	-	201143-7
	5	5	.030 OUNCES	-	-	.032±.003	-	-	-	201143-5
	5	5	.030 OUNCES	-	-	.042±.003	-	-	-	201143-3
	5	5	.030 OUNCES	-	-	.023±.003	-	-	-	201143-1
CONTACT PLATING	SHELL PLATING	WEIGHT	CABLE OR WIRE SIZE	CRIMP TOOL	Y	3 FERRULE QTY=1	2 SPRING RETENTION QTY=1	1 PIN ASSY QTY=1	PART NUMBER	

THIS DRAWING IS A CONTROLLED DOCUMENT.

DIMENSIONS: INCHES	TOLERANCES UNLESS OTHERWISE SPECIFIED:	0 PLC ± -	1 PLC ± -	2 PLC ± .008	3 PLC ± -	4 PLC ± -	ANGLES ± -									
MATERIAL		FINISH		WEIGHT	SEE TABLE	SIZE	A1	CAGE CODE	00779	DRAWING NO	C=201143	RESTRICTED TO	-			
CUSTOMER DRAWING											SCALE	8:1	SHEET	1 OF 1	REV	AZ1

STE TE Connectivity
PIN, MINIATURE SERIES
108-12021