

SURFACE MOUNT LED LAMP STANDARD BRIGHT PLCC-2

QTLP670C-2 HER

QTLP670C-3 Yellow

QTLP670C-4 Green

QTLP670C-7 AlGaAs Red

QTLP670C-B Blue

QTLP670C-W White

PACKAGE DIMENSIONS

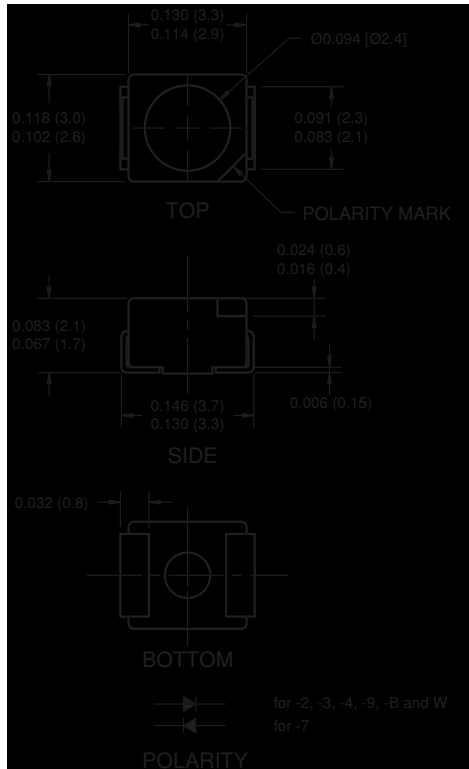

NOTE:
Dimensions for all drawings are in inches (mm).

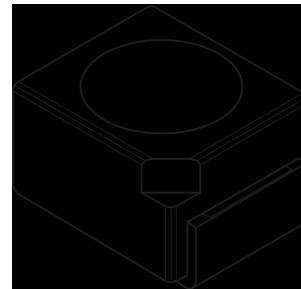

APPLICATIONS

- Automotive interior lighting
- Status indication for consumer electronics and office equipment

DESCRIPTION

These surface mount LEDs are designed with flat top and sides for the ease of pick-and-place by automatic placement equipment. They are compatible with convective IR and vapor phase reflow soldering. The package size and configuration conform to EIA-535 BAAC standard specification for case size 3528 tantalum capacitor. These LEDs are ideal for backlighting and optical coupling into light pipes.

FEATURES

- GaN/SIC technology for -B and -W
- Wide viewing angle of 120°
- Water clear optics
- Moisture-proof packaging
- Available in 0.315" (8mm) width tape on 7" (178mm) diameter reel; 2,000 units per reel

SURFACE MOUNT LED LAMP

STANDARD BRIGHT PLCC-2

QTLP670C-2 HER

QTLP670C-3 Yellow

QTLP670C-4 Green

QTLP670C-7 AlGaAs Red

QTLP670C-B Blue

QTLP670C-W White

ABSOLUTE MAXIMUM RATINGS ($T_A = 25^\circ\text{C}$ Unless otherwise specified)								
Parameter	Symbol	QTLP670C						Units
		-2	-3	-4	-7	-B	-W	
Continuous Forward Current	I_F	30	30	30	30	30	30	mA
Peak Forward Current ($f = 1.0 \text{ KHz}$, Duty Factor = 1/10)	I_{FM}	160	160	160	180	100	100	mA
Reverse Voltage ($I_R = 10 \mu\text{A}$)	V_R	5	5	5	5	5	5	V
Power Dissipation	P_D	84	84	84	72	135	135	mW
Operating Temperature	T_{OPR}	-40 to +85						$^\circ\text{C}$
Storage Temperature	T_{STG}	-40 to +90						$^\circ\text{C}$
Lead Soldering Time	T_{SOL}	260 for 5 sec						$^\circ\text{C}$

ELECTRICAL / OPTICAL CHARACTERISTICS ($T_A = 25^\circ\text{C}$)								
Part Number	Symbol	QTLP670C						Condition
		-2	-3	-4	-7	-B	-W	
Luminous Intensity (mcd)	I_V	5	5	15	25	20	20	$I_F = 20\text{mA}$
Minimum		10	10	25	40	30	30	
Forward Voltage (V)	V_F	2.8	2.8	2.8	2.4	4.5	4.5	$I_F = 20\text{mA}$
Maximum		2.0	2.0	2.1	1.9	3.8	3.8	
Wavelength (nm)	λ_P	635	585	565	660	430	—	$I_F = 20\text{mA}$
Peak		630	590	570	645	465	—	
Dominant	λ_D	630	590	570	645	465	—	$I_F = 20\text{mA}$
Chromatic Coordinate	x,y	—	—	—	—	—	$x = 0.26$ $y = 0.28$	$I_F = 20\text{mA}$
Spectral Line Half Width (nm)	$\Delta\lambda$	45	35	30	20	65	—	$I_F = 20\text{mA}$
Viewing Angle ($^\circ$)	$2\theta_{1/2}$	120	120	120	120	120	120	$I_F = 20\text{mA}$

QTLP670C-2 HER

QTLP670C-3 Yellow

QTLP670C-4 Green

QTLP670C-7 AlGaAs Red

QTLP670C-B Blue

QTLP670C-W White

TYPICAL PERFORMANCE CURVES

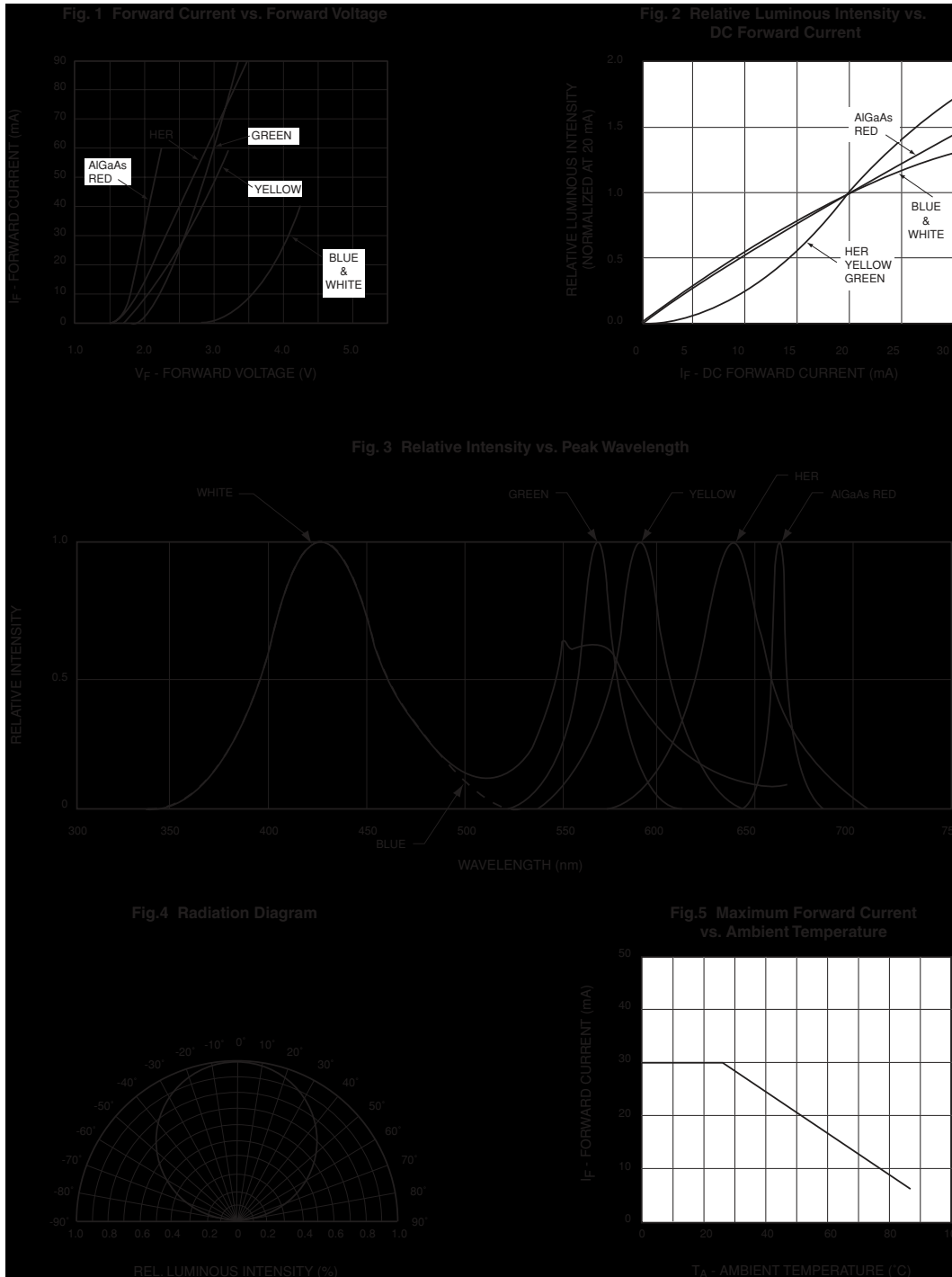

SURFACE MOUNT LED LAMP STANDARD BRIGHT PLCC-2

QTLP670C-2 HER

QTLP670C-3 Yellow

QTLP670C-4 Green

QTLP670C-7 AlGaAs Red

QTLP670C-B Blue

QTLP670C-W White

RECOMMENDED PRINTED CIRCUIT BOARD PATTERN

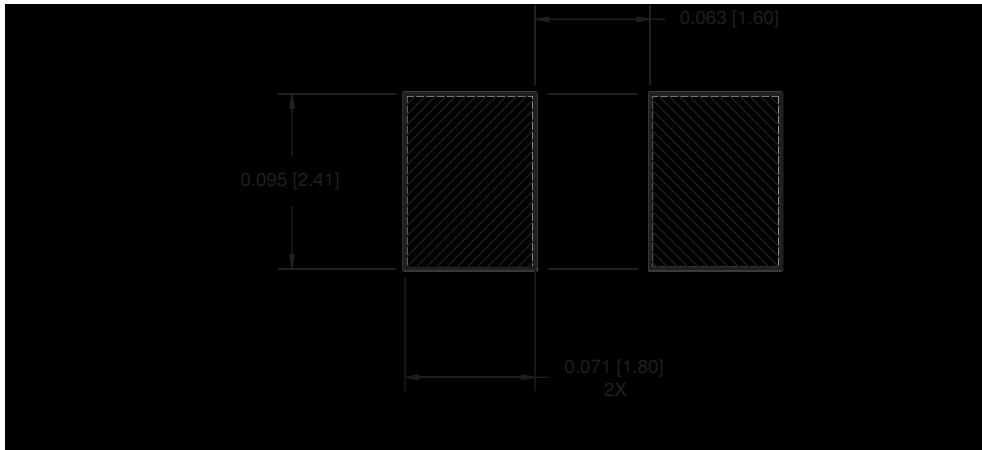

RECOMMENDED IR REFLOW SOLDERING PROFILE

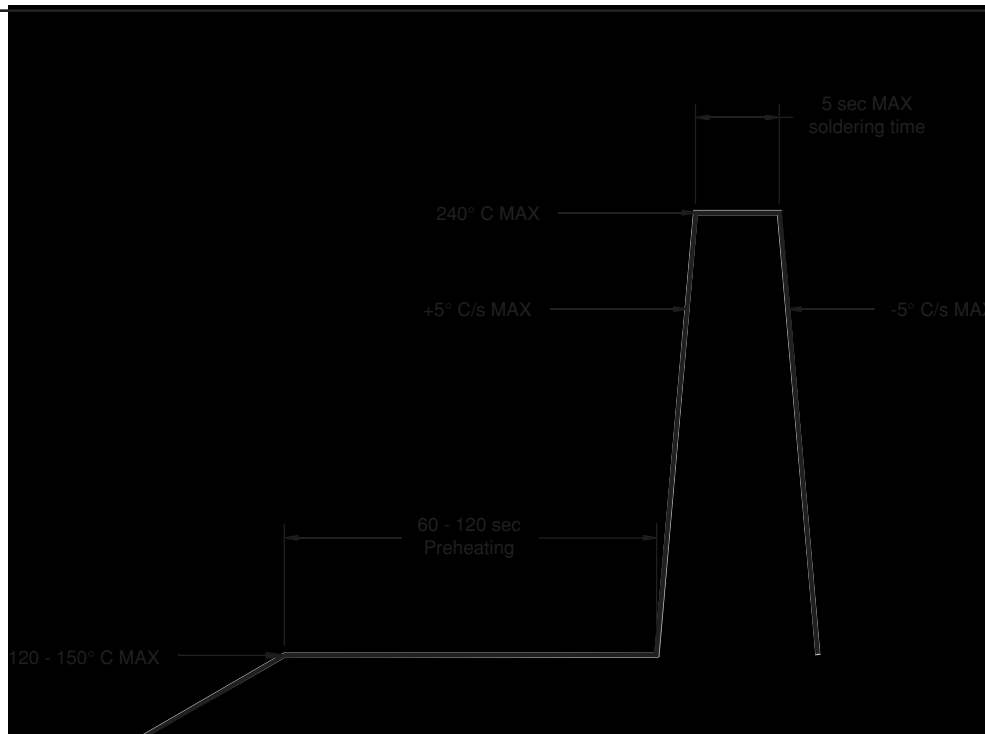

SURFACE MOUNT LED LAMP STANDARD BRIGHT PLCC-2

QTLP670C-2 HER

QTLP670C-3 Yellow

QTLP670C-4 Green

QTLP670C-7 AlGaAs Red

QTLP670C-B Blue

QTLP670C-W White

TAPE AND REEL DIMENSIONS

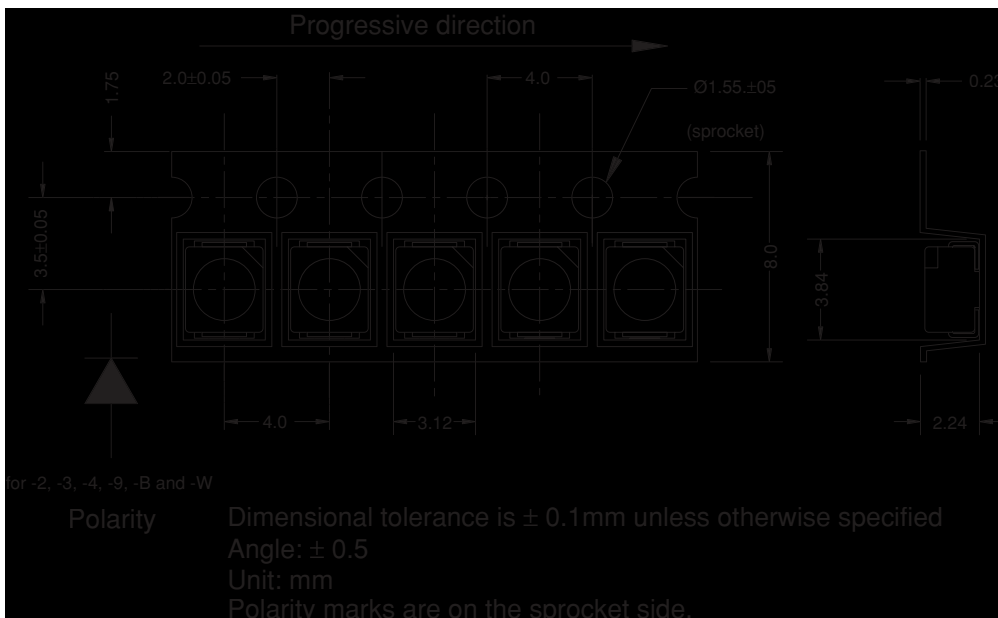
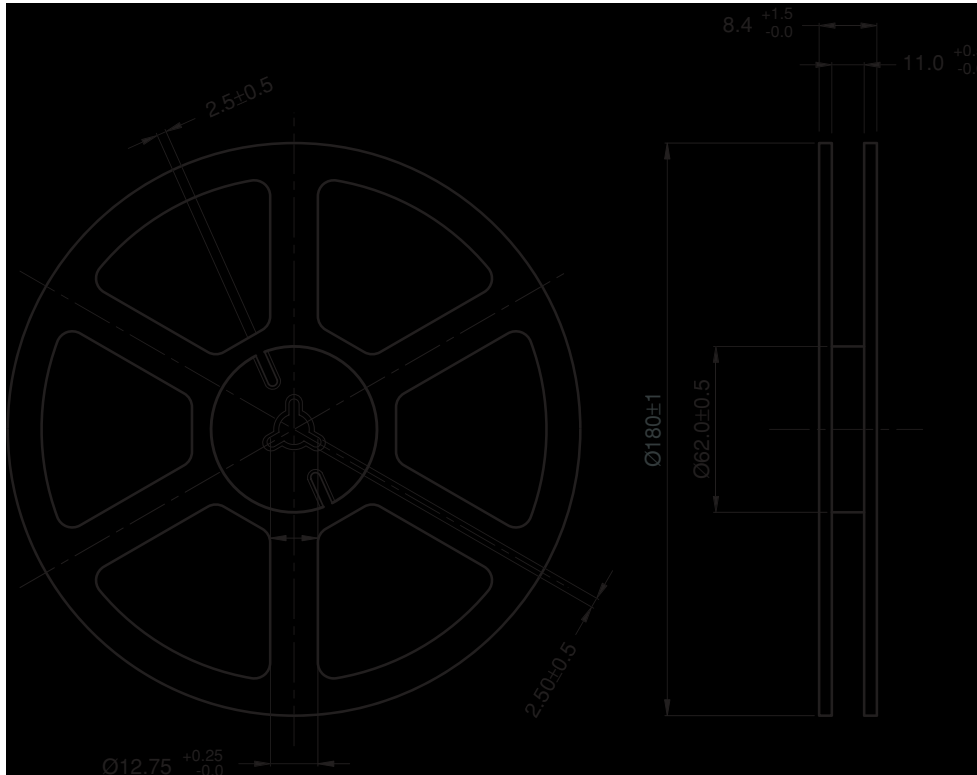



SURFACE MOUNT LED LAMP

STANDARD BRIGHT PLCC-2

QTLP670C-2 HER

QTLP670C-3 Yellow

QTLP670C-4 Green

QTLP670C-7 AlGaAs Red

QTLP670C-B Blue

QTLP670C-W White

TAPE AND REEL DIMENSIONS

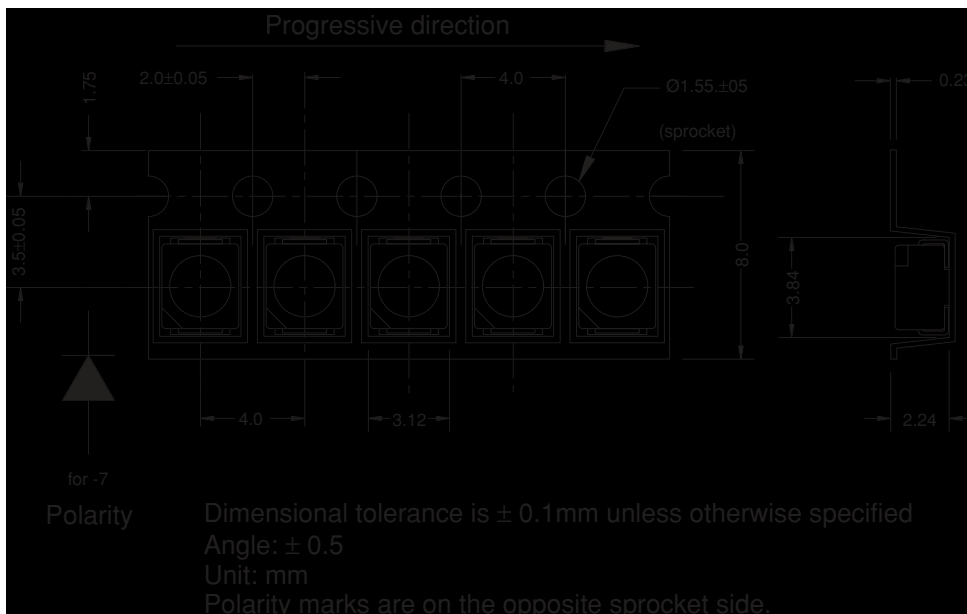
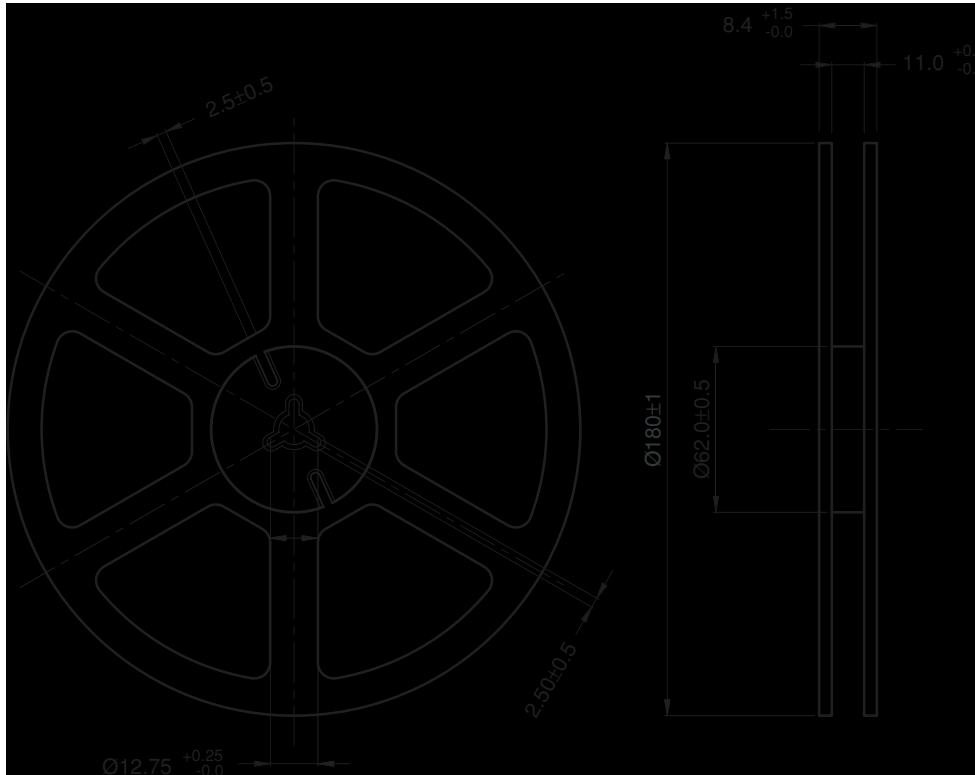



SURFACE MOUNT LED LAMP STANDARD BRIGHT PLCC-2

QTLP670C-2 HER

QTLP670C-3 Yellow

QTLP670C-4 Green

QTLP670C-7 AlGaAs Red

QTLP670C-B Blue

QTLP670C-W White

DISCLAIMER

FAIRCHILD SEMICONDUCTOR RESERVES THE RIGHT TO MAKE CHANGES WITHOUT FURTHER NOTICE TO ANY PRODUCTS HEREIN TO IMPROVE RELIABILITY, FUNCTION OR DESIGN. FAIRCHILD DOES NOT ASSUME ANY LIABILITY ARISING OUT OF THE APPLICATION OR USE OF ANY PRODUCT OR CIRCUIT DESCRIBED HEREIN; NEITHER DOES IT CONVEY ANY LICENSE UNDER ITS PATENT RIGHTS, NOR THE RIGHTS OF OTHERS.

LIFE SUPPORT POLICY

FAIRCHILD'S PRODUCTS ARE NOT AUTHORIZED FOR USE AS CRITICAL COMPONENTS IN LIFE SUPPORT DEVICES OR SYSTEMS WITHOUT THE EXPRESS WRITTEN APPROVAL OF THE PRESIDENT OF FAIRCHILD SEMICONDUCTOR CORPORATION. As used herein:

1. Life support devices or systems are devices or systems which, (a) are intended for surgical implant into the body, or (b) support or sustain life, and (c) whose failure to perform when properly used in accordance with instructions for use provided in the labeling, can be reasonably expected to result in a significant injury of the user.
2. A critical component in any component of a life support device or system whose failure to perform can be reasonably expected to cause the failure of the life support device or system, or to affect its safety or effectiveness.