

REVISIONS				
REV	DATE	DESCRIPTION	BY	APPV
F	06MAR2018	REV PER ECO 18-000365	CT	EO

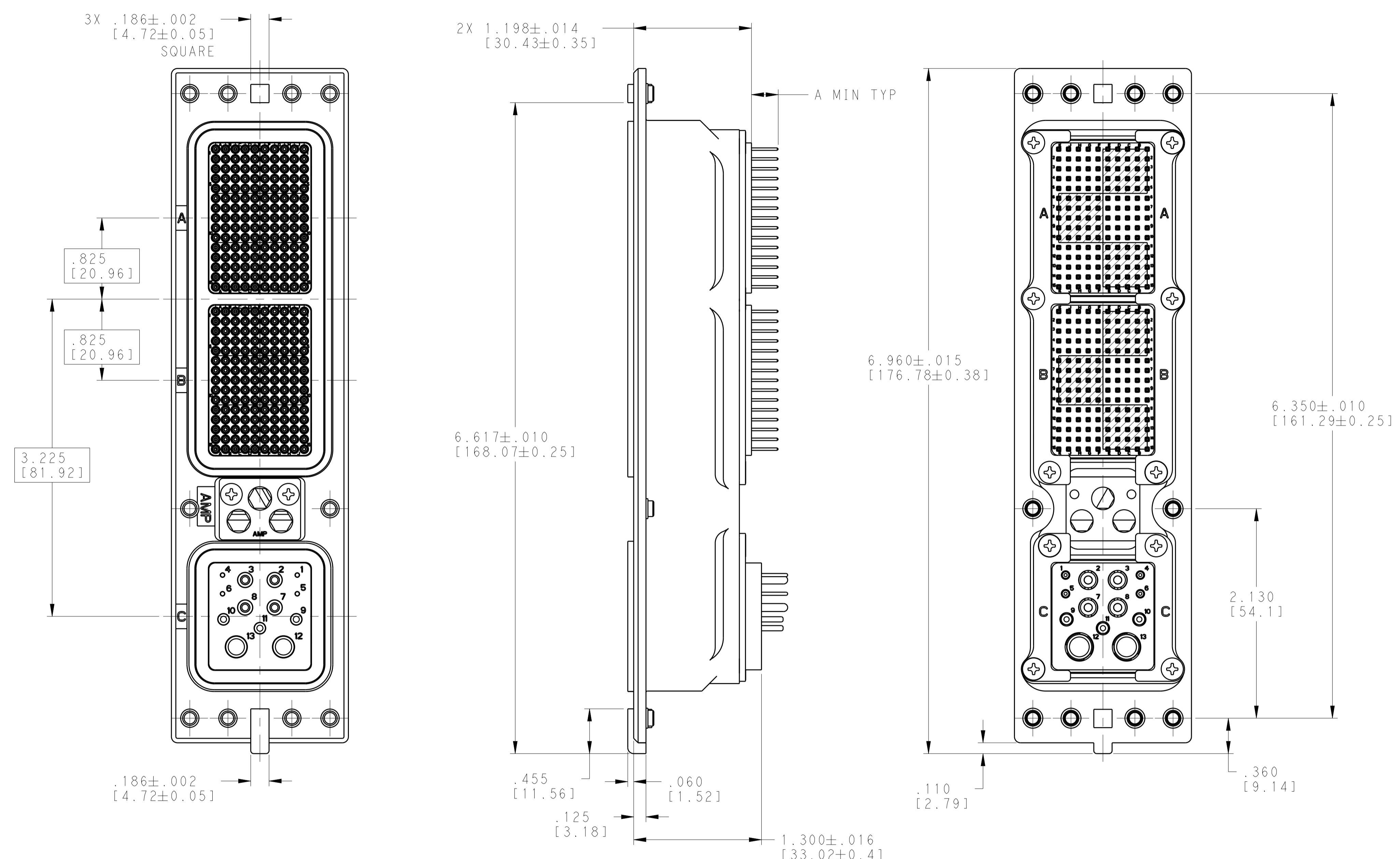
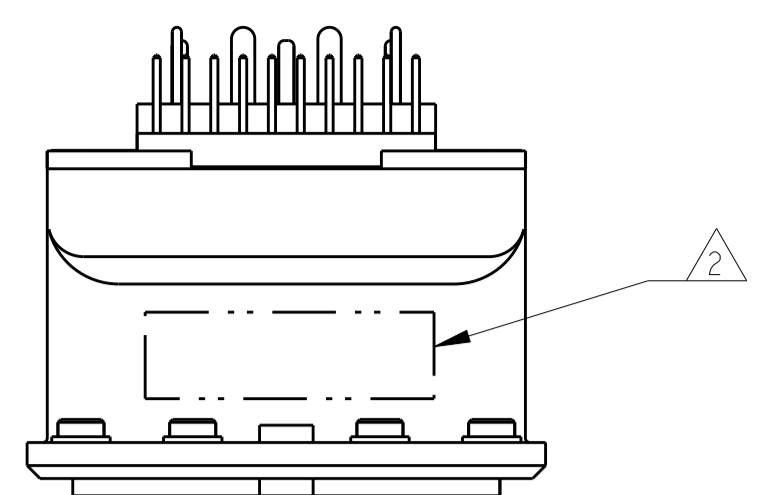

- CONNECTOR MUST MEET TE SPEC 108-10019, & 129-1136.
 - TE PART NO. & DATE CODE MARKED IN AREA SHOWN.
 - KEYING SHOWN IN POSITION "94" FOR REFERENCE ONLY. SEE TABLE FOR KEYING POSITION FOR ALL DASH NUMBERS PER DRAWING 204014.
 - DUST COVER INSTALLED FOR SHIPPING (NOT SHOWN).
 - CONNECTOR IS SUPPLIED WITH CONTACTS (PER TABLE) ASSEMBLED AS SHOWN FOR -3. FOR -1 AND -2 SZ 22 POSTED SOCKET CONTACTS ARE INSTALLED. CRIMP CONTACTS AND FILLER PLUGS FOR MODULE "C" ARE PACKAGED SEPARATELY AND SHIPPED WITH CONNECTOR.
- PRELIMINARY- NOT RELEASED FOR PRODUCTION

MODULE	CONTACTS INCLUDED	PART NUMBER
MODULE A SZ 22 POSTED SOCKET CONTACT, TE P/N 211431-4 (QTY = 150)	MODULE B SZ 22 POSTED SOCKET CONTACT, TE P/N 211431-4 (QTY = 150)	1883359-3
MODULE C SZ 20 POSTED PIN CONTACT, TE P/N 1663533-2 (QTY = 4)	SZ 16 POSTED PIN CONTACT, TE P/N 1663128-5 (QTY = 3)	
SZ 12 POSTED PIN CONTACT, TE P/N 1663129-5 (QTY = 4)	SZ 5 FILLER PLUG, TE P/N 1663132-1 (QTY = 2)	
MODULE A SZ 22 POSTED SOCKET CONTACT, TE P/N 211431-2 (QTY = 150)	MODULE B SZ 22 POSTED SOCKET CONTACT, TE P/N 211431-2 (QTY = 150)	1883359-2
MODULE C SZ 20 CRIMP PIN CONTACT, TE P/N 208265-3 (QTY = 1)	SZ 12 CRIMP PIN CONTACT, TE P/N 208271-3 (QTY = 2)	
SZ 20 FILLER PLUG, TE P/N 1663767-6 (QTY = 3)	SZ 16 FILLER PLUG, TE P/N 1663767-7 (QTY = 3)	
MODULE A SZ 22 POSTED SOCKET CONTACT, TE P/N 211431-2 (QTY = 150)	MODULE B SZ 22 POSTED SOCKET CONTACT, TE P/N 211431-2 (QTY = 150)	1883359-1
MODULE C SZ 20 CRIMP PIN CONTACT, TE P/N 208265-3 (QTY = 4)	SZ 16 CRIMP PIN CONTACT, TE P/N 208268-3 (QTY = 3)	
CONTACTS INCLUDED		

COMPONENT	MATERIAL	FINISH
13C2 INSERT ASSY REAR RELEASE/REMOVE	THERMOSET	--
150 POSITION INSERT FRONT RELEASE/REMOVE	THERMOSET	--
POLARIZATION POST	ZINC ALLOY PER ASTM-B-86	ELECTROLESS NICKEL
KEYWAY RETAINER PLATE	ALUMINUM ALLOY	BLUE ANODIZED PER MIL-A-8625
#6-32 CLINCH NUT 10 PLC	STEEL	CADMIUM PLATE (-1 & -2) ZINC PLATE (-3)
#4-40 RETAINER SCREW 10 PLC	STAINLESS STEEL	PASSIVATED
INSERT RETENTION PLATE	ALUMINUM ALLOY PER ASTM-B-209	CHROMATE CONVERSION PER MIL-DTL-5541 CLASS 3, TYPE II
RECEPTACLE SHELL	ALUMINUM ALLOY PER ASTM-B-85	CHROMATE CONVERSION PER MIL-DTL-5541 CLASS 3, TYPE II

1883359-3 SHOWN

DIM A	KEYING POSITION	PART NO.
.250 MIN	"94"	1883359-3
.150 MIN	"02"	1883359-2
.150 MIN	"06"	1883359-1

THIS DRAWING IS A CONTROLLED DOCUMENT. DWG: C.C. THOMAS 3-19-18
CHK: E. OCHOA 3-19-18
APPV: E. OCHOA 3-19-18

STE TE Connectivity

NAME: RCPT ASSY, SZ 2, ARINC 600 (150/150/13C2)
PRODUCT SPEC: -
APPLICATION SPEC: -
SIZE: - CAGE CODE: - DRAWING NO: A100779
WEIGHT: -
RESTRICTED CUSTOMER

SCALE: 3:2 SHEET 1 OF 1 REV D