

Important notice

Dear Customer,

On 7 February 2017 the former NXP Standard Product business became a new company with the tradename **Nexperia**. Nexperia is an industry leading supplier of Discrete, Logic and PowerMOS semiconductors with its focus on the automotive, industrial, computing, consumer and wearable application markets

In data sheets and application notes which still contain NXP or Philips Semiconductors references, use the references to Nexperia, as shown below.

Instead of <http://www.nxp.com>, <http://www.philips.com/> or <http://www.semiconductors.philips.com/>, use <http://www.nexperia.com>

Instead of sales.addresses@www.nxp.com or sales.addresses@www.semiconductors.philips.com, use salesaddresses@nexperia.com (email)

Replace the copyright notice at the bottom of each page or elsewhere in the document, depending on the version, as shown below:

- © NXP N.V. (year). All rights reserved or © Koninklijke Philips Electronics N.V. (year). All rights reserved

Should be replaced with:

- © **Nexperia B.V. (year). All rights reserved.**

If you have any questions related to the data sheet, please contact our nearest sales office via e-mail or telephone (details via salesaddresses@nexperia.com). Thank you for your cooperation and understanding,

Kind regards,

Team Nexperia

DATA SHEET

74LVT162240A

**3.3 V LVT 16-bit inverting buffer/driver
with 30 Ω termination resistors (3-State)**

Product data
Supersedes data of 1998 Feb 19

2003 Feb 21

3.3 V LVT 16-bit inverting buffer/driver with 30 Ω termination resistors (3-State)

74LVT162240A

FEATURES

- 16-bit bus interface
- 3-State buffers
- Output capability: +12 mA/-12 mA
- TTL input and output switching levels
- Input and output interface capability to systems at 5 V supply
- Bus-hold data inputs eliminate the need for external pull-up resistors to hold unused inputs
- Live insertion/extraction permitted
- Outputs include series resistance of 30 Ω making external termination resistors unnecessary
- Power-up 3-State
- No bus current loading when output is tied to 5 V bus
- Latch-up protection exceeds 500 mA per JEDEC Std 17
- ESD protection exceeds 2000 V per MIL STD 883 Method 3015 and 200 V per Machine Model
- Same part as 74LVT16240A-1

DESCRIPTION

The 74LVT162240A is a high-performance BiCMOS product designed for V_{CC} operation at 3.3 V.

This device is an inverting 16-bit buffer that is ideal for driving bus lines. The device features four Output Enables ($1\overline{OE}$, $2\overline{OE}$, $3\overline{OE}$, $4\overline{OE}$), each controlling four of the 3-State outputs.

The 74LVT162240A is designed with 30 Ω series resistance in both the pull-up and pull-down output structures. This design reduces line noise in applications such as memory address drivers, clock drivers, and bus receivers/transmitters.

The 74LVT162240A is the same as the 74LVT16240A-1. The part number has been changed to reflect industry standards.

QUICK REFERENCE DATA

SYMBOL	PARAMETER	CONDITIONS $T_{amb} = 25\text{ }^{\circ}\text{C}$	TYPICAL	UNIT
t_{PLH} t_{PHL}	Propagation delay nA_x to nY_x	$C_L = 50\text{ pF}$; $V_{CC} = 3.3\text{ V}$	2.6	ns
C_{IN}	Input capacitance $n\overline{OE}$	$V_I = 0\text{ V or }3.0\text{ V}$	3	pF
C_{OUT}	Output capacitance	$V_O = 0\text{ V or }3.0\text{ V}$	9	pF
I_{CCZ}	Total supply current	Outputs disabled; $V_{CC} = 3.6\text{ V}$	70	μA

ORDERING INFORMATION

PACKAGES	TEMPERATURE RANGE	PART NUMBER	DWG NUMBER
48-Pin Plastic SSOP Type III	-40 °C to +85 °C	74LVT162240ADL	SOT370-1
48-Pin Plastic TSSOP Type II	-40 °C to +85 °C	74LVT162240ADGG	SOT362-1

LOGIC SYMBOL

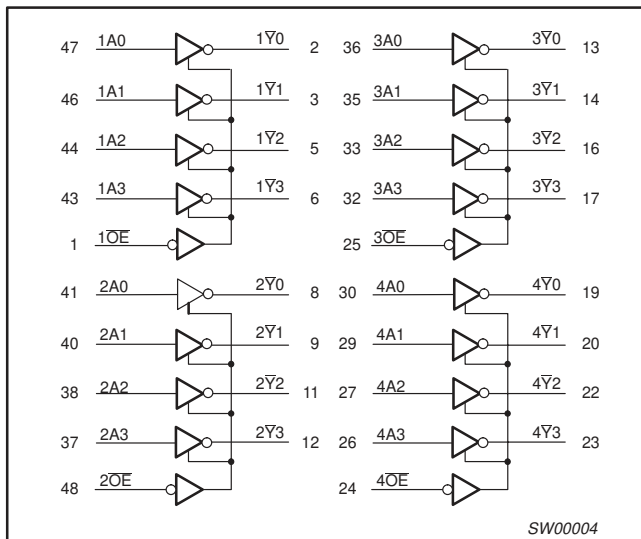

3.3 V LVT 16-bit inverting buffer/driver with 30 Ω termination resistors (3-State)

74LVT162240A

LOGIC SYMBOL (IEEE/IEC)

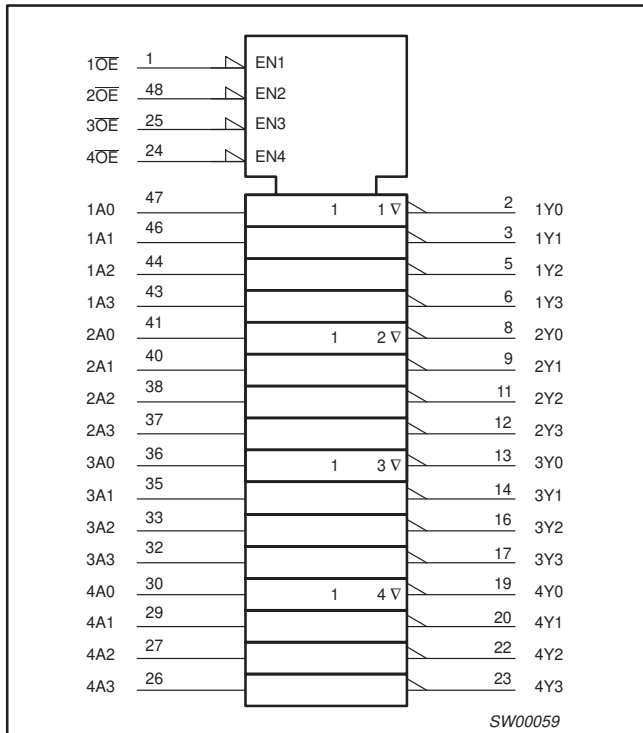

PIN CONFIGURATION

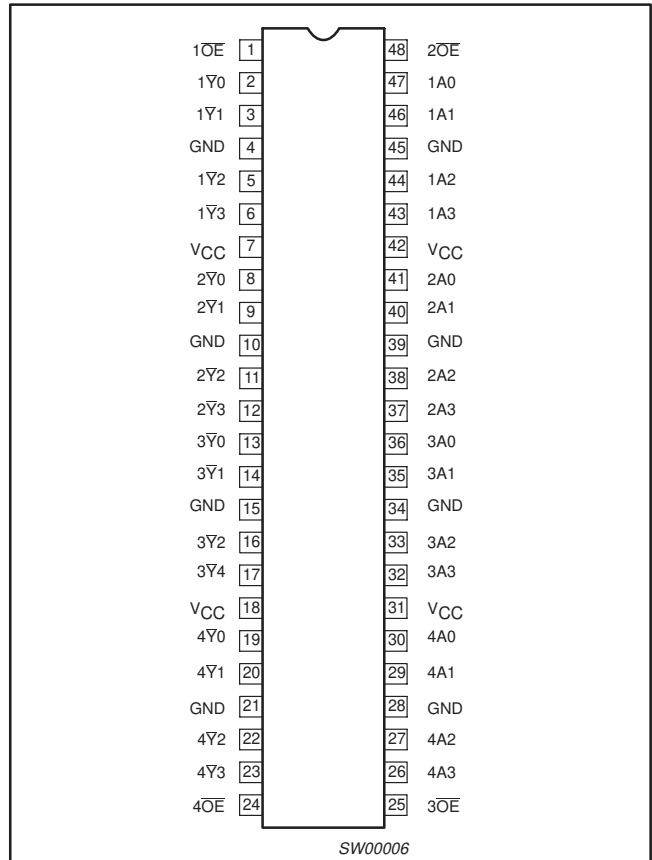

FUNCTION TABLE

INPUTS		OUTPUTS
nOE	nAx	nYx
L	L	H
L	H	L
H	X	Z

H = HIGH voltage level
 L = LOW voltage level
 X = Don't care
 Z = High Impedance "off" state

SCHEMATIC OF EACH OUTPUT

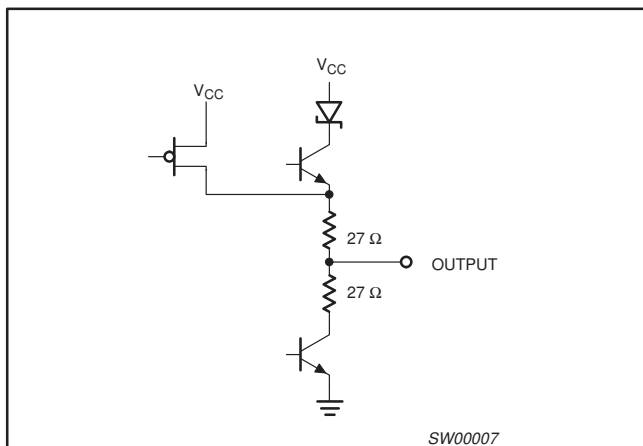

PIN DESCRIPTION

PIN NUMBER	SYMBOL	NAME AND FUNCTION
47, 46, 44, 43, 41, 40, 38, 37, 36, 35, 33, 32, 30, 29, 27, 26	1A0 – 1A3 2A0 – 2A3 3A0 – 3A3 4A0 – 4A3	Data inputs
2, 3, 5, 6, 8, 9, 11, 12, 13, 14, 16, 17, 19, 20, 22, 23	1Y0 – 1Y3 2Y0 – 2Y3 3Y0 – 3Y3 4Y0 – 4Y3	Data outputs
1, 48, 25, 24	1OE, 2OE, 3OE, 4OE	Output enables
4, 10, 15, 21, 28, 34, 39, 45	GND	Ground (0 V)
7, 18, 31, 42	VCC	Positive supply voltage

3.3 V LVT 16-bit inverting buffer/driver with 30 Ω termination resistors (3-State)

74LVT162240A

ABSOLUTE MAXIMUM RATINGS^{1, 2}

SYMBOL	PARAMETER	CONDITIONS	RATING	UNIT
V _{CC}	DC supply voltage		-0.5 to +4.6	V
I _{IK}	DC input diode current	V _I < 0 V	-50	mA
V _I	DC input voltage ³		-0.5 to +7.0	V
I _{OK}	DC output diode current	V _O < 0 V	-50	mA
V _{OUT}	DC output voltage ³	Output in Off or HIGH state	-0.5 to +7.0	V
I _{OUT}	DC output current	Output in LOW state	128	mA
		Output in HIGH state	-64	
T _{stg}	Storage temperature range		-65 to +150	°C

NOTES:

- Stresses beyond those listed may cause permanent damage to the device. These are stress ratings only and functional operation of the device at these or any other conditions beyond those indicated under "recommended operating conditions" is not implied. Exposure to absolute-maximum-rated conditions for extended periods may affect device reliability.
- The performance capability of a high-performance integrated circuit in conjunction with its thermal environment can create junction temperatures which are detrimental to reliability. The maximum junction temperature of this integrated circuit should not exceed 150 °C.
- The input and output negative voltage ratings may be exceeded if the input and output clamp current ratings are observed.

RECOMMENDED OPERATING CONDITIONS

SYMBOL	PARAMETER	LIMITS		UNIT
		MIN	MAX	
V _{CC}	DC supply voltage	2.7	3.6	V
V _I	Input voltage	0	5.5	V
V _{IH}	HIGH-level input voltage	2.0		V
V _{IL}	Input voltage		0.8	V
I _{OH}	HIGH-level output current		-12	mA
I _{OL}	LOW-level output current		12	mA
$\Delta t/\Delta v$	Input transition rise or fall rate; Outputs enabled		10	ns/V
T _{amb}	Operating free-air temperature range	-40	+85	°C

3.3 V LVT 16-bit inverting buffer/driver with 30 Ω termination resistors (3-State)

74LVT162240A

DC ELECTRICAL CHARACTERISTICS

SYMBOL	PARAMETER	TEST CONDITIONS	LIMITS			UNIT	
			$T_{amb} = -40^{\circ}\text{C to } +85^{\circ}\text{C}$				
			MIN	TYP ¹	MAX		
V_{IK}	Input clamp voltage	$V_{CC} = 2.7\text{ V}; I_{IK} = -18\text{ mA}$		-0.85	1.2	V	
V_{OH}	HIGH-level output voltage	$V_{CC} = 3.0\text{ V}; I_{OH} = -12\text{ mA}$	2.0			V	
V_{OL}	LOW-level output voltage	$V_{CC} = 3.0\text{ V}; I_{OL} = 12\text{ mA}$			0.8	V	
I_I	Input leakage current	$V_{CC} = 3.6\text{ V}; V_I = V_{CC}$ or GND	Control pins		0.1	± 1	μA
		$V_{CC} = 0\text{ V or } 3.6\text{ V}; V_I = 5.5\text{ V}$			0.4	10	
		$V_{CC} = 3.6\text{ V}; V_I = V_{CC}$	Data pins ⁴		0.1	1	
		$V_{CC} = 3.6\text{ V}; V_I = 0\text{ V}$		-0.4	-5		
I_{OFF}	Output off current	$V_{CC} = 0\text{ V}; V_I$ or $V_O = 0\text{ V to } 4.5\text{ V}$		0.1	± 100	μA	
I_{HOLD}	Bus Hold current A outputs ⁶	$V_{CC} = 3\text{ V}; V_I = 0.8\text{ V}$	75	135		μA	
		$V_{CC} = 3\text{ V}; V_I = 2.0\text{ V}$	-75	-135			
		$V_{CC} = 0\text{ V to } 3.6\text{ V}; V_{CC} = 3.6\text{ V}$	± 500				
I_{EX}	Current into an output in the HIGH state when $V_O > V_{CC}$	$V_O = 5.5\text{ V}; V_{CC} = 3.0\text{ V}$		50	125	μA	
$I_{PU/PD}$	Power-up/down 3-State output current ³	$V_{CC} \leq 1.2\text{ V}; V_O = 0.5\text{ V to } V_{CC}; V_I = \text{GND or } V_{CC}$ OE/OE = Don't care		1	± 100	μA	
I_{OZH}	3-State output HIGH current	$V_{CC} = 3.6\text{ V}; V_O = 3.0\text{ V}; V_I = V_{IL}$ or V_{IH}		0.5	5	μA	
I_{OZL}	3-State output LOW current	$V_{CC} = 3.6\text{ V}; V_O = 0.5\text{ V}; V_I = V_{IL}$ or V_{IH}		0.5	-5	μA	
I_{CCH}	Quiescent supply current	$V_{CC} = 3.6\text{ V};$ Outputs HIGH, $V_I = \text{GND or } V_{CC}, I_O = 0$		0.07	0.12	mA	
I_{CCL}		$V_{CC} = 3.6\text{ V};$ Outputs LOW, $V_I = \text{GND or } V_{CC}, I_O = 0$		4.0	6		
I_{CCZ}		$V_{CC} = 3.6\text{ V};$ Outputs Disabled; $V_I = \text{GND or } V_{CC}, I_O = 0^5$		0.07	0.12		
ΔI_{CC}	Additional supply current per input pin ²	$V_{CC} = 3\text{ V to } 3.6\text{ V};$ One input at $V_{CC}-0.6\text{ V},$ Other inputs at V_{CC} or GND		0.1	0.20	mA	

NOTES:

- All typical values are at $V_{CC} = 3.3\text{ V}$ and $T_{amb} = 25^{\circ}\text{C}$.
- This is the increase in supply current for each input at the specified voltage level other than V_{CC} or GND.
- This parameter is valid for any V_{CC} between 0 V and 1.2 V with a transition time of up to 10 msec. From $V_{CC} = 1.2\text{ V to } V_{CC} = 3.3\text{ V} \pm 0.3\text{ V}$ a transition time of 100 μsec is permitted. This parameter is valid for $T_{amb} = 25^{\circ}\text{C}$ only.
- Unused pins at V_{CC} or GND.
- I_{CCZ} is measured with outputs pulled to V_{CC} or GND.
- This is the bus hold overdrive current required to force the input to the opposite logic state.

3.3 V LVT 16-bit inverting buffer/driver with 30 Ω termination resistors (3-State)

74LVT162240A

AC CHARACTERISTICS

GND = 0 V; $t_R = t_F = 2.5$ ns; $C_L = 50$ pF; $R_L = 500$ Ω; $T_{amb} = -40$ °C to $+85$ °C.

SYMBOL	PARAMETER	WAVEFORM	LIMITS				UNIT
			$V_{CC} = 3.3$ V ± 0.3 V			$V_{CC} = 2.7$ V	
			MIN	TYP ¹	MAX	MAX	
t_{PLH} t_{PHL}	Propagation delay nAx to nYx	1	0.5 0.5	2.6 2.6	4.2 4.2	5.0 5.0	ns
t_{PZH} t_{PZL}	Output enable time to HIGH and LOW level	2	1.0 1.0	3.3 3.0	5.5 5.0	6.5 5.5	ns
t_{PHZ} t_{PLZ}	Output disable time from HIGH and LOW Level	2	1.0 1.0	3.5 3.2	5.0 4.5	5.5 4.5	ns

NOTE:

1. All typical values are at $V_{CC} = 3.3$ V and $T_{amb} = 25$ °C.

AC WAVEFORMS

$V_M = 1.5$ V; $V_{IN} = GND$ to 2.7 V

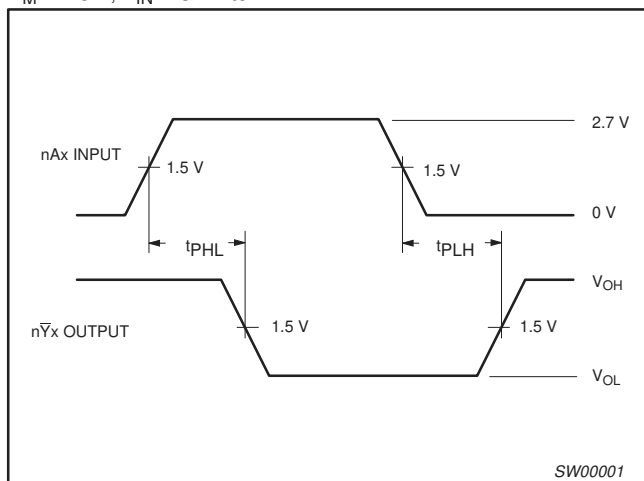

Waveform 1. Input (nAx) to Output (nYx) Propagation Delays

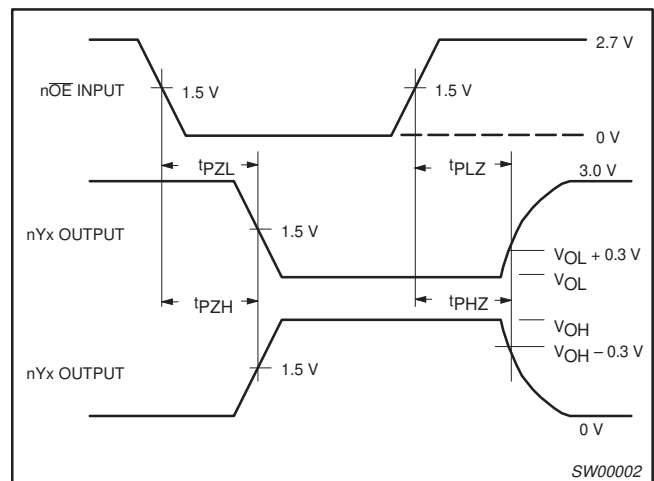

Waveform 2. 3-State Output Enable and Disable Times

3.3 V LVT 16-bit inverting buffer/driver with 30 Ω termination resistors (3-State)

74LVT162240A

TEST CIRCUIT AND WAVEFORMS

Test Circuit for 3-State Outputs

SWITCH POSITION

TEST	SWITCH
t_{PHZ}/t_{PZH}	GND
t_{PLZ}/t_{PZL}	6 V
t_{PLH}/t_{PHL}	open

DEFINITIONS

R_L = Load resistor; see AC CHARACTERISTICS for value.

C_L = Load capacitance includes jig and probe capacitance; see AC CHARACTERISTICS for value.

R_T = Termination resistance should be equal to Z_{OUT} of pulse generators.

**$V_M = 1.5 V$
Input Pulse Definition**

FAMILY	INPUT PULSE REQUIREMENTS				
	Amplitude	Rep. Rate	t_W	t_R	t_F
74LVT16	2.7 V	≤ 10 MHz	500 ns	≤ 2.5 ns	≤ 2.5 ns

SW00003

3.3 V LVT 16-bit inverting buffer/driver
with 30 Ω termination resistors (3-State)

74LVT162240A

SSOP48: plastic shrink small outline package; 48 leads; body width 7.5 mm

SOT370-1

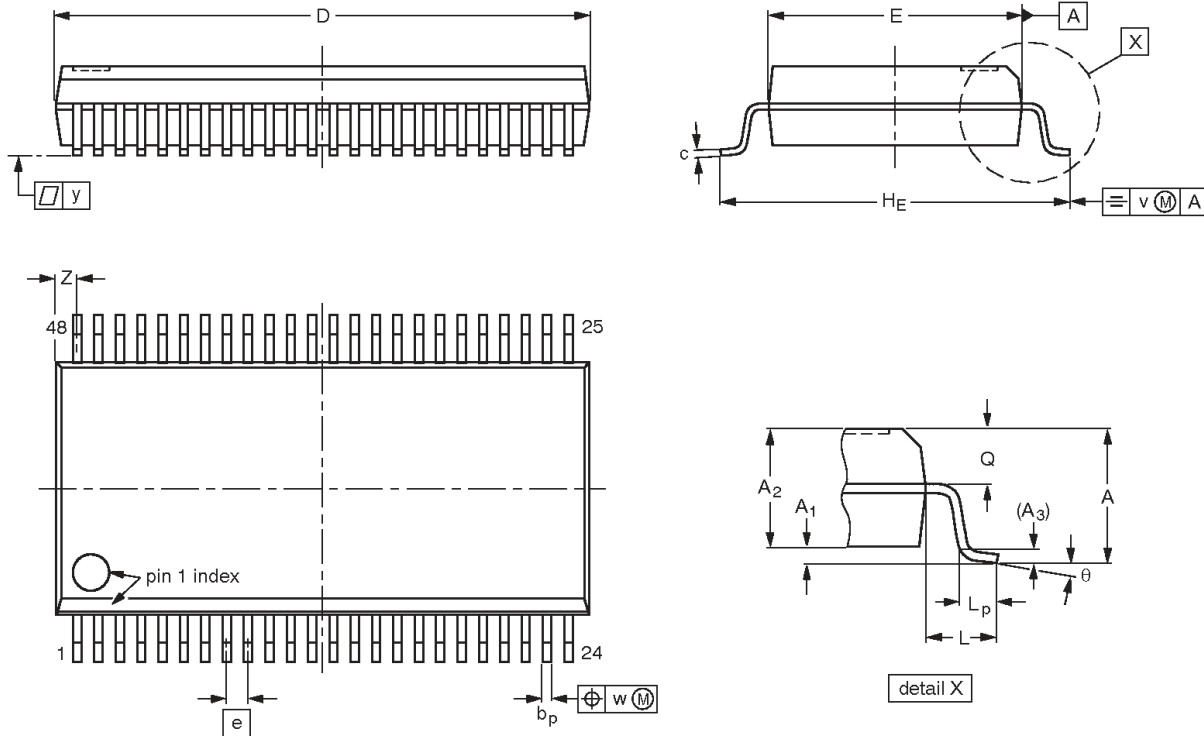

DIMENSIONS (mm are the original dimensions)

UNIT	A max.	A ₁	A ₂	A ₃	b _p	c	D ⁽¹⁾	E ⁽¹⁾	e	H _E	L	L _p	Q	v	w	y	Z ⁽¹⁾	θ
mm	2.8	0.4 0.2	2.35 2.20	0.25	0.3 0.2	0.22 0.13	16.00 15.75	7.6 7.4	0.635	10.4 10.1	1.4	1.0 0.6	1.2 1.0	0.25	0.18	0.1	0.85 0.40	8° 0°

Note

1. Plastic or metal protrusions of 0.25 mm maximum per side are not included.

OUTLINE VERSION	REFERENCES				EUROPEAN PROJECTION	ISSUE DATE
	IEC	JEDEC	EIAJ			
SOT370-1		MO-118				95-02-04 99-12-27

3.3 V LVT 16-bit inverting buffer/driver with 30 Ω termination resistors (3-State)

74LVT162240A

TSSOP48: plastic thin shrink small outline package; 48 leads; body width 6.1 mm

SOT362-1

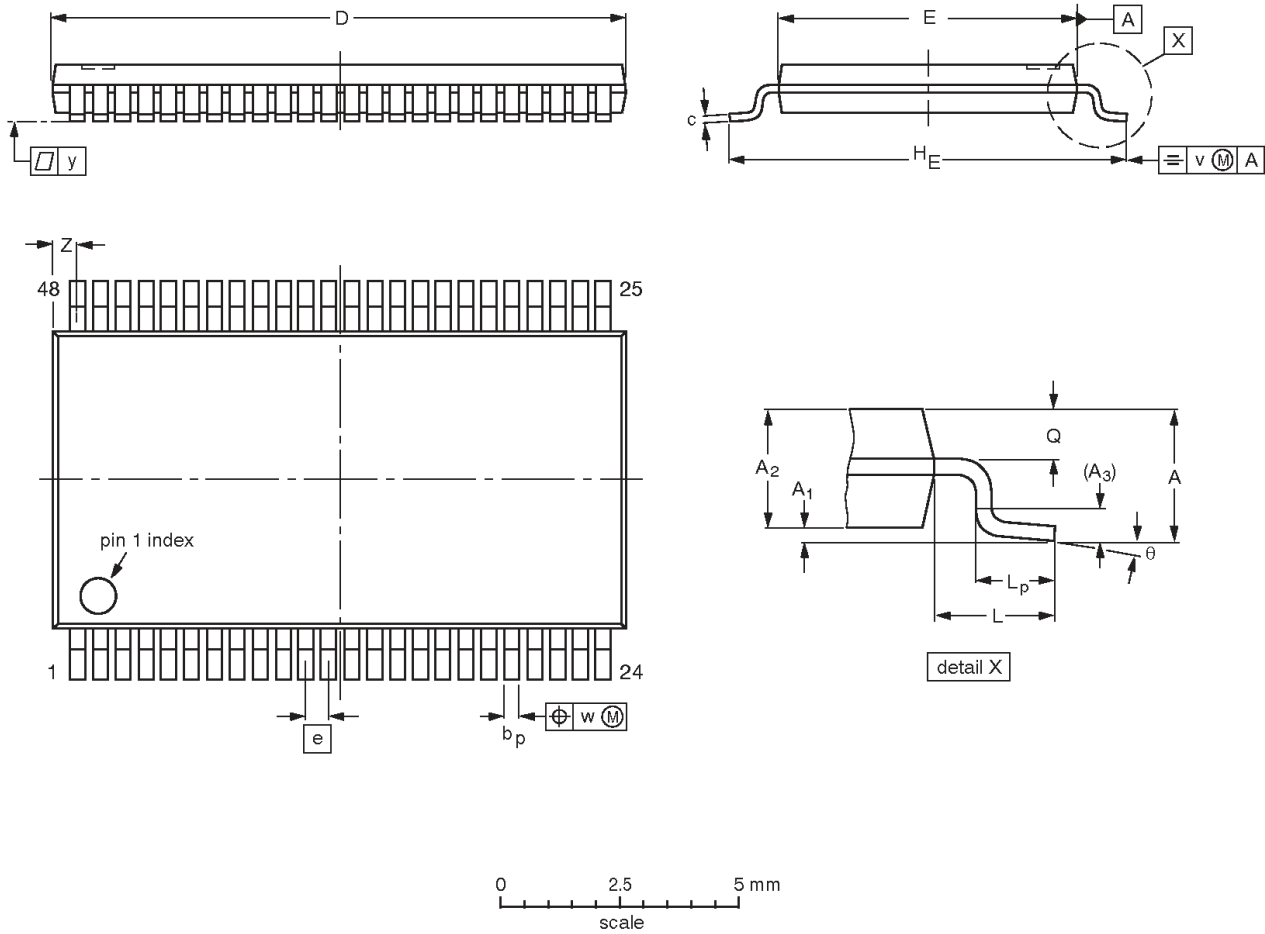

DIMENSIONS (mm are the original dimensions).

UNIT	A max.	A ₁	A ₂	A ₃	b _p	c	D ⁽¹⁾	E ⁽²⁾	e	H _E	L	L _p	Q	v	w	y	Z	θ
mm	1.2	0.15 0.05	1.05 0.85	0.25	0.28 0.17	0.2 0.1	12.6 12.4	6.2 6.0	0.5	8.3 7.9	1	0.8 0.4	0.50 0.35	0.25	0.08	0.1	0.8 0.4	8° 0°

Notes

1. Plastic or metal protrusions of 0.15 mm maximum per side are not included.
2. Plastic interlead protrusions of 0.25 mm maximum per side are not included.

OUTLINE VERSION	REFERENCES				EUROPEAN PROJECTION	ISSUE DATE
	IEC	JEDEC	EIAJ			
SOT362-1		MO-153				-95-02-10 99-12-27

3.3 V LVT 16-bit inverting buffer/driver with 30 Ω termination resistors (3-State)

74LVT162240A

REVISION HISTORY

Rev	Date	Description
_3	20030221	Product data (9397 750 11157); ECN 853-1777 29438 of 29 January 2003; supersedes data of 1998 Feb 19 (9397 750 03548). Modifications: <ul style="list-style-type: none"> Ordering information table on page 2 corrected: remove 'North America' column. "Logic symbol (IEEE/IEC)" on page 3 modified to correct pin names.
_2	19980219	Product specification (9397 750 03548); ECN 853-1777 18990; supersedes data of 1995 Aug 22.

Data sheet status

Level	Data sheet status ^[1]	Product status ^{[2] [3]}	Definitions
I	Objective data	Development	This data sheet contains data from the objective specification for product development. Philips Semiconductors reserves the right to change the specification in any manner without notice.
II	Preliminary data	Qualification	This data sheet contains data from the preliminary specification. Supplementary data will be published at a later date. Philips Semiconductors reserves the right to change the specification without notice, in order to improve the design and supply the best possible product.
III	Product data	Production	This data sheet contains data from the product specification. Philips Semiconductors reserves the right to make changes at any time in order to improve the design, manufacturing and supply. Relevant changes will be communicated via a Customer Product/Process Change Notification (CPCN).

[1] Please consult the most recently issued data sheet before initiating or completing a design.

[2] The product status of the device(s) described in this data sheet may have changed since this data sheet was published. The latest information is available on the Internet at URL <http://www.semiconductors.philips.com>.

[3] For data sheets describing multiple type numbers, the highest-level product status determines the data sheet status.

Definitions

Short-form specification — The data in a short-form specification is extracted from a full data sheet with the same type number and title. For detailed information see the relevant data sheet or data handbook.

Limiting values definition — Limiting values given are in accordance with the Absolute Maximum Rating System (IEC 60134). Stress above one or more of the limiting values may cause permanent damage to the device. These are stress ratings only and operation of the device at these or at any other conditions above those given in the Characteristics sections of the specification is not implied. Exposure to limiting values for extended periods may affect device reliability.

Application information — Applications that are described herein for any of these products are for illustrative purposes only. Philips Semiconductors make no representation or warranty that such applications will be suitable for the specified use without further testing or modification.

Disclaimers

Life support — These products are not designed for use in life support appliances, devices, or systems where malfunction of these products can reasonably be expected to result in personal injury. Philips Semiconductors customers using or selling these products for use in such applications do so at their own risk and agree to fully indemnify Philips Semiconductors for any damages resulting from such application.

Right to make changes — Philips Semiconductors reserves the right to make changes in the products—including circuits, standard cells, and/or software—described or contained herein in order to improve design and/or performance. When the product is in full production (status 'Production'), relevant changes will be communicated via a Customer Product/Process Change Notification (CPCN). Philips Semiconductors assumes no responsibility or liability for the use of any of these products, conveys no license or title under any patent, copyright, or mask work right to these products, and makes no representations or warranties that these products are free from patent, copyright, or mask work right infringement, unless otherwise specified.

Contact information

For additional information please visit
<http://www.semiconductors.philips.com>. Fax: +31 40 27 24825

© Koninklijke Philips Electronics N.V. 2003
 All rights reserved. Printed in U.S.A.

Date of release: 02-03

For sales offices addresses send e-mail to:
sales.addresses@www.semiconductors.philips.com.

Document order number:

9397 750 11157

Let's make things better.