

THIS DRAWING AND THE SUBJECT MATTER SHOWN THEREON ARE CONFIDENTIAL AND THE PROPERTY OF BEL/STEWART/TRP CONNECTOR AND SHALL NOT BE REPRODUCED, COPIED, OR USED IN ANY MANNER WITHOUT THE WRITTEN CONSENT OF TRP CONNECTOR.

PRODUCT MAY BE PROTECTED BY ONE OR MORE OF THE FOLLOWING US PATENTS:
 5736910 5939955 6425781 6428361 6554638 6840817 7123117
 7429195 7717749 7808751 6217391 6149050 7924130

REVISIONS				
#	DATE	DESCRIPTION	BY	APPV
4	21JAN2015	COMPANY LOGO CHANGE	DP	TY

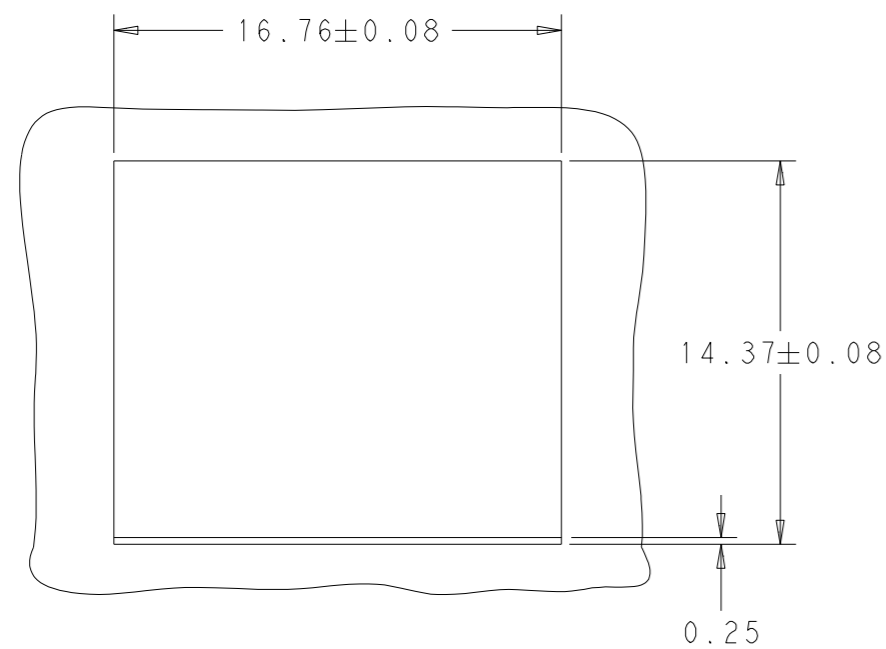
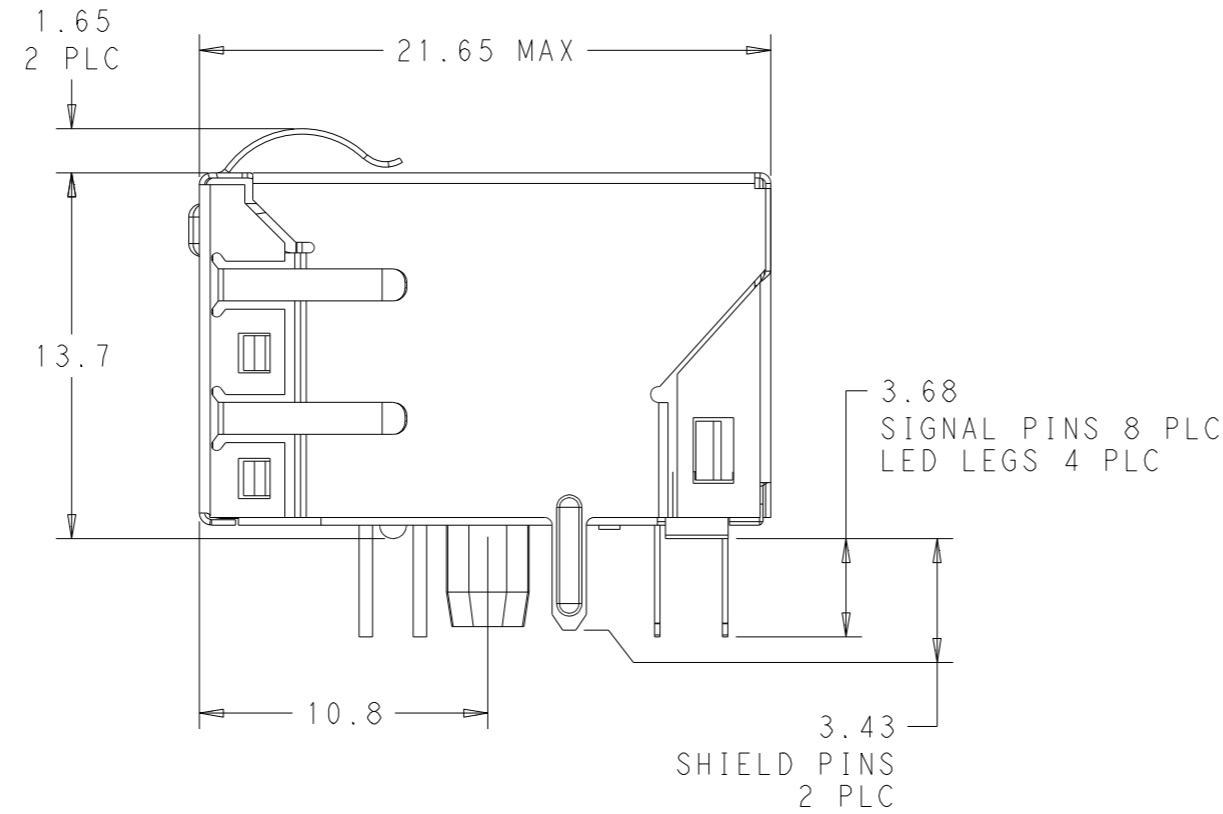
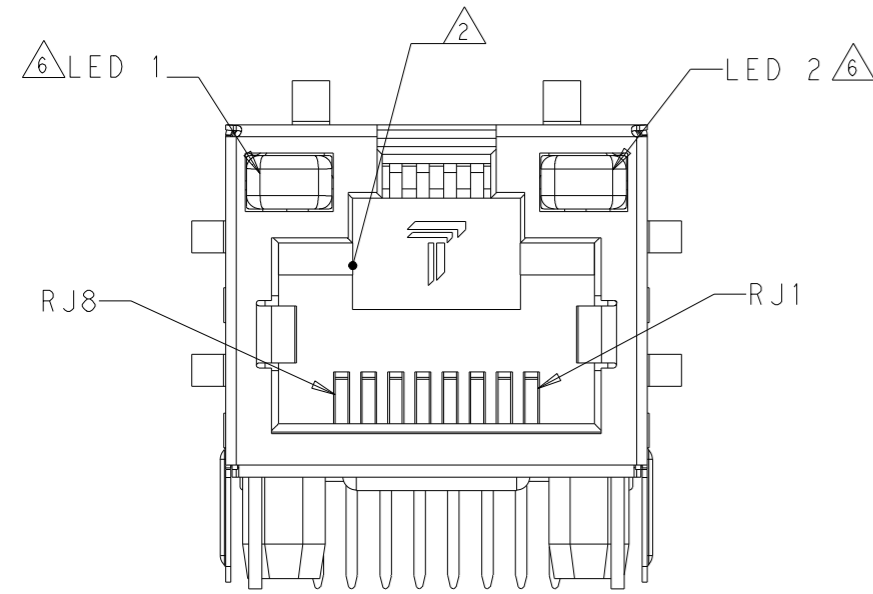
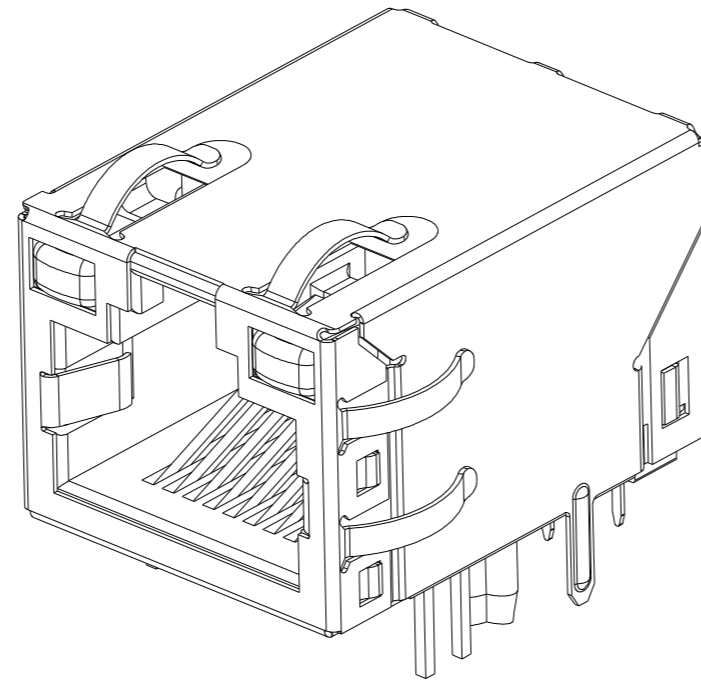
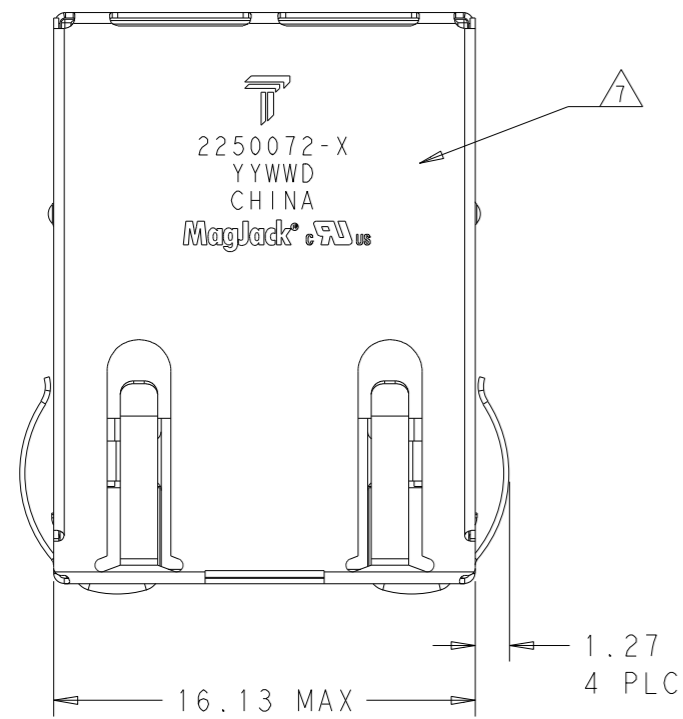

SUGGESTED PANEL CUTOUT

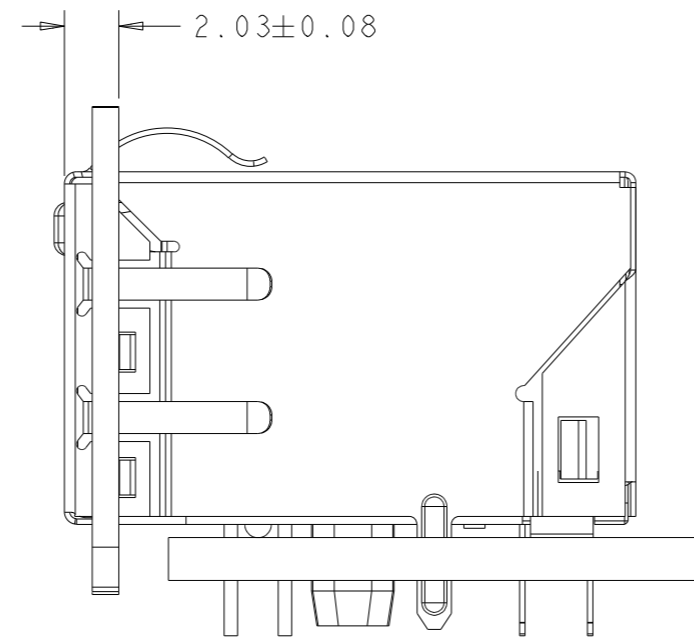

1. MATERIALS

- HOUSING: THERMOPLASTIC, FLAMMABILITY RATING UL 94V-0.
- SHIELD: BRASS 0.20mm THICK, PREPLATED WITH 0.76um MIN SEMI-BRIGHT NICKEL. SOLDER TABS POST DIPPED WITH 2.54um MIN SAC SOLDER.
- CONTACTS: PHOSPHOR BRONZE 0.46mm X 0.30mm, PHOSPHOR BRONZE, 1.27um MIN NICKEL UNDERPLATE, WITH 1.27um MIN GOLD PLATING AT MATING INTERFACE AND 2.54um MIN MATTE TIN ON SOLDER TAILS, OR 1.27um MIN NICKEL UNDERPLATE, WITH 0.05um GOLD PLATING OVER 0.76um MIN PALLADIUM NICKEL PLATING AT MATING INTERFACE AND 2.54um MIN MATTE TIN ON SOLDER TAILS.
- SOLDER TAILS: 0.25mm THICK, PHOSPHOR BRONZE, 1.27um MIN OVERALL NICKEL UNDERPLATE, 3um TIN PLATE
- LIGHT EMITTING DIODE (LED): DIFFUSED EPOXY LENS, 0.5mm X 0.5mm CARBON STEEL WIREFRAME LEADS PREPLATED WITH 2.03um MIN. SILVER PLATE OVER 1.02um MIN. NICKEL OVER 1.02um MIN. COPPER UNDERPLATE; LEADS POST-PLATED WITH 3.05um MIN. MATTE TIN, AND THEN TIP TIN SOLDER DIPPING

△ RJ45 JACK CAVITY CONFORMS TO FCC RULES AND REGULATIONS PART 68 SUB PART F.

△ MAGNETICS

- APPLICATION: 10/100 BASE-T
- IMPEDANCE: 100 OHMS
- TURNS RATIO (CHIP:CABLE): TX=1:1.41, RX=1:1
- OPEN CIRCUIT INDUCTANCE (OCL): 350uH MIN @100kHz, 0.1VRMS, 8mADC BIAS FROM 0°C TO 70°C, TX AND RX
- PERFORMANCE @ 25°C:
 - INSERTION LOSS (IL): 1.1dB MAX FROM 0.5MHz TO 100MHz
 - RETURN LOSS (RL): 18dB MIN FROM 0.5MHz TO 30MHz
 - 18-20LOG(f/30)dB MIN FROM 30.1MHz TO 60MHz
 - 12dB MIN FROM 60.1MHz TO 80MHz
 - CROSSTALK ATTENUATION: 35dB MIN FROM 0.5MHz TO 40MHz
 - 33-20LOG(f/50)dB MIN FROM 40.1MHz TO 100MHz
 - COMMON MODE REJECTION RATIO (CMRR): 30dB MIN FROM 0.5MHz TO 100MHz
- ISOLATION VOLTAGE: 2250VDC FOR 60 SECONDS WITH A RISE TIME OF 500 V/SEC

4. OPERATING TEMPERATURE: FROM 0°C TO +70°C.

△ INDICATED MAGNETIC CONNECTIONS ARE SYMMETRICAL TO SUPPORT AUTO-MDI/MDIX.

△ THE LEDS WITH BUILT-IN 250 OHM RESISTORS, AND ARE DRIVEN WITH 5V VOLTAGE AND THE MAX OPERATING CURRENT IS 20mA

LED COLOR: DOMINATE WAVELENGTH (λD): GREEN 568 nm TYP. @ VF=5V
 FORWARD CURRENT (IF): GREEN 12mA TYP @ VF = 5V
 DOMINATE WAVELENGTH (λD): YELLOW 588 nm TYP. @ VF=5V
 FORWARD CURRENT (IF): YELLOW 13mA TYP @ VF = 5V

△ TRP CONNECTOR LOGO, PART NUMBER, DATE CODE, COUNTRY OF ORIGIN AND AGENCY APPROVAL MARKING IN APPROXIMATE LOCATION SHOWN.

8. PART SHOULD BE RECOMMENDED FOR WAVE SOLDERING PROCESS, PREHEAT TEMPERATURE IS 120°C TO 160°C, 120 SECONDS TO 180 SECONDS, PEAK WAVE SOLDERING TEMPERATURE IS 260°C MAX, 10 SECONDS MAX.

GREEN	YELLOW	2250072-2
GREEN	GREEN	2250072-1
9	10	11
12		
LED 1	LED 2	PART NUMBER

THIS DRAWING IS A CONTROLLED DOCUMENT.		DWN ROY LIU 30DEC2013	trp CONNECTOR a bel group		DONGGUAN CHINA
DIMENSIONS: mm		CHK TOWER YU/ FRANK LIU 30DEC2013	DESC IXI 726 10/100 TAB UP W/ LED		
TOLERANCES UNLESS OTHERWISE SPECIFIED:		APV TONY YUAN 30DEC2013	MODEL NAME MAGJACK		
0 PLC ±0.25		SIZE A 1			
1 PLC ±0.25		CAGE CODE -			
2 PLC ±0.25		DRAWING NO C=2250072			
3 PLC ±0.25		RESTRICTED TO -			
4 PLC ±		SCALE 4:1			
ANGLES ±		SHEET 1 OF 3			
PRODUCT SPEC 108-104004		APPLICATION SPEC -			
CUSTOMER DRAWING		REV 4			

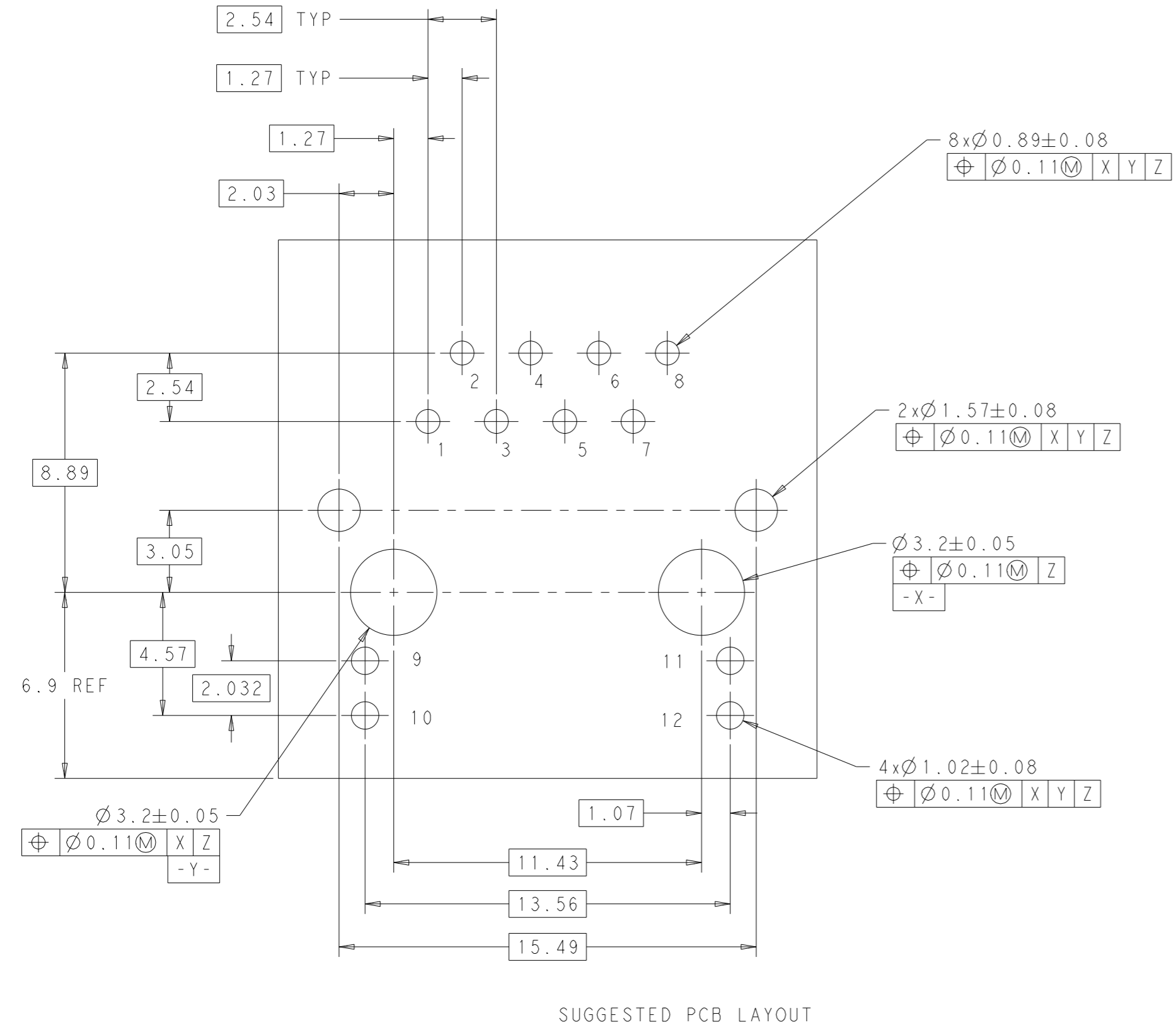

SUGGESTED PCB LAYOUT

726 10/100 CIRCUIT

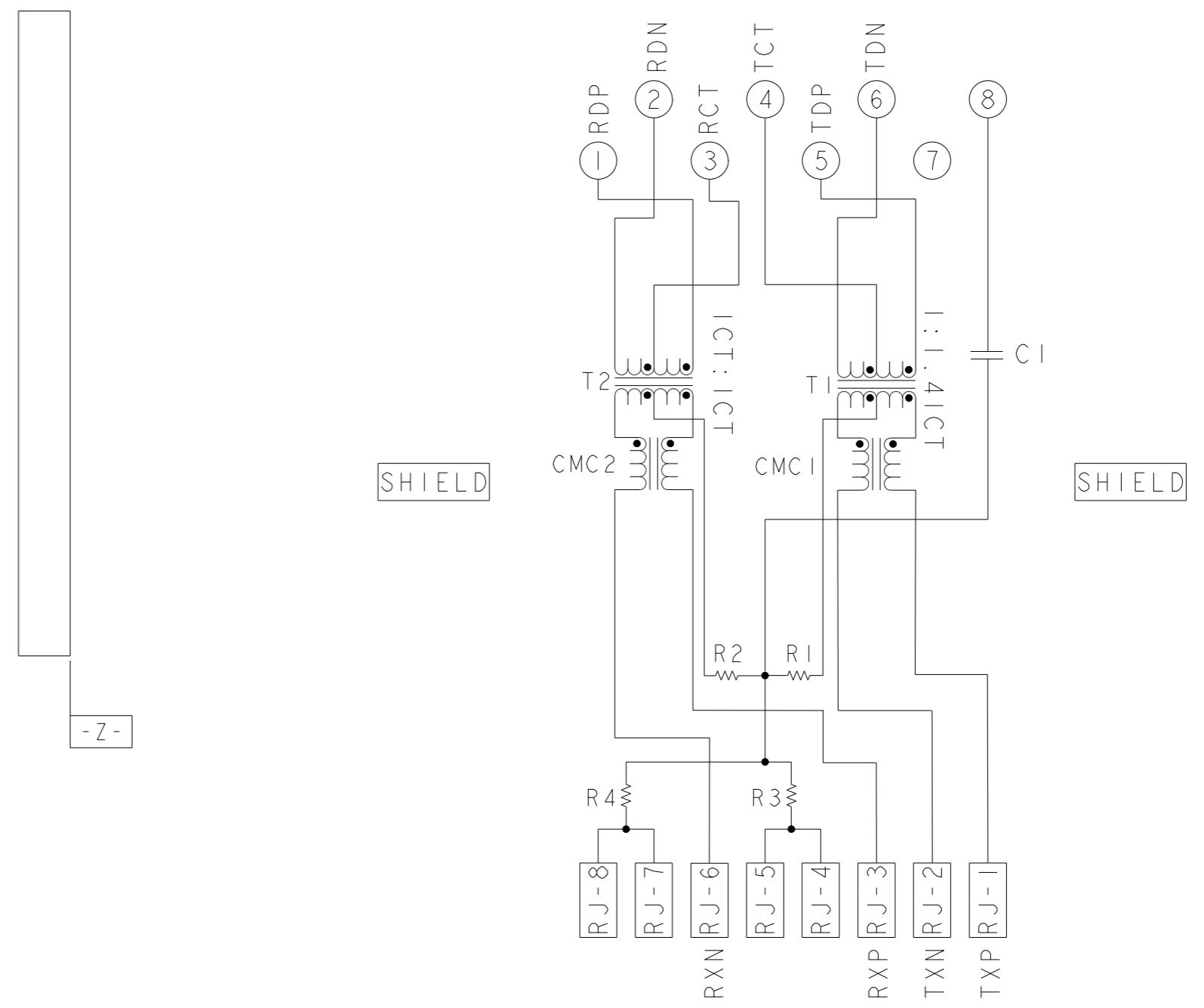

C1=1000pF, 2kV CAPACITOR
 R1-R4 = 75 Ohms, 1/16 W RESISTORS

THIS DRAWING IS A CONTROLLED DOCUMENT.		DWN: ROY LIU 30DEC2013 CHK: TOWER YU/ FRANK LIU 30DEC2013 APVD: TONY YUAN 30DEC2013	DONGGUAN CHINA
DIMENSIONS: mm TOLERANCES UNLESS OTHERWISE SPECIFIED: 0 PLC ±0.25 1 PLC ±0.25 2 PLC ±0.25 3 PLC ±0.25 4 PLC ± ANGLES ±°	MODEL NAME: MAGJACK DESC: SINGLE NON-POE	SIZE: A1 CAGE CODE: C=2250072 DRAWING NO: 108-104004	

C_2250072					STOCK DISPOSITION			
REVISION HISTORY					A: CONTINUE AS IS		D: USE OLD FIRST	
					B: REWORK		E: PARTS TO CONFORM	
					C: SCRAP		F: OTHER	
DATE	REV	CHANGES	REASON	APPROVAL	INVENTORY (A,B,C,D,E,F)	WORK IN PROCESS (A,B,C,F)	SUPPLIER ORDERS (A,E,F)	OPEN CUST ORDERS (A,E,F)
30DEC2013	1	-	INITIAL RELEASE	TONY YUAN	-	-	-	-
09APR2014	2	ADD DASH NUMBER 2250072-2	MARKET REQUIREMENT	TONY YUAN	-	-	-	-
28AUG2014	3	SHEET 1, C6: CHANGE 1.27 TO 1.65	PRODUCT IMPROVEMENT	TONY YUAN	-	-	-	-
21JAN2015	4	EC-1411035 COMPANY LOGO CHANGE	MARKET REQUEST	TONY YUAN	-	-	-	-

THIS DRAWING IS A CONTROLLED DOCUMENT.

DIMENSIONS: mm	TOLERANCES UNLESS OTHERWISE SPECIFIED: 0 PLC ±0.25 1 PLC ±0.25 2 PLC ±0.25 3 PLC ±0.25 4 PLC ± ANGLES ±	DWN ROY LIU 30DEC2013 CHK TOWER YU/ FRANK LIU 30DEC2013 APVD TONY YUAN 30DEC2013 MODEL NAME MAGJACK DESC SINGLE NON-POE CUSTOMER DRAWING	 trp CONNECTOR a bel group DONGGUAN CHINA
PRODUCT SPEC 108-104004	APPLICATION SPEC -	SIZE A1 CAGE CODE DRAWING NO. C=2250072 SCALE 4:1 SHEET 3 OF 3 REV 4	DESC IXI 726 10/100 TAB UP W/ LED RESTRICTED TO