



MIC28304 Evaluation Board

70V 3A Power Module
Hyper Speed Control™ Family

General Description

The Micrel MIC28304 is synchronous step-down regulator module, featuring a unique adaptive ON-time control architecture. The module incorporates a DC-to-DC controller, power MOSFETs, bootstrap diode, bootstrap capacitor, and an inductor in a single package. The MIC28304 operates over an input supply range of 4.5V to 70V and can be used to supply up to 3A of output current. The output voltage is adjustable down to 0.8V with a guaranteed accuracy of $\pm 1\%$. The device operates with a programmable switching frequency from 200kHz to 600kHz.

The MIC28304-1 has the HyperLight Load® architecture, so it can operate in pulse skipping mode at light load. However, it operates in fixed frequency CCM mode from medium load to heavy load. The MIC28304-2 has Hyper Speed Control™ architecture, which operates in fixed frequency CCM mode under all load conditions.

The basic parameters of the evaluation board are:

- Input: 7V to 70V
- Output: 0.8V to 5V at 3A⁽¹⁾
- 600kHz Switching Frequency (Adjustable 200kHz to 600kHz)

Note:

1. Refer to temperature curves shown in the [MIC28304 0.8V to 5V/3A Evaluation Board Typical Characteristics](#) section.

Datasheets and support documentation are available on Micrel's web site at: www.micrel.com.

Requirements

The MIC28304-1 and MIC28304-2 evaluation board requires only a single power supply with at least 10A current capability. No external linear regulator is required to power the internal biasing of the IC because the MIC28304 has internal PVDD LDO. In the applications with $V_{IN} < +5.5V$, PVDD should be tied to VIN to bypass the internal linear regulator. The output load can either be a passive or an active load.

Precautions

The MIC28304 evaluation board does not have reverse polarity protection. Applying a negative voltage to the VIN and GND terminals may damage the device. The maximum VIN of the board is rated at 70V. Exceeding 70V on the VIN could damage the device.

Hyper LightLoad is a registered trademark and Hyper Speed Control is a trademark of Micrel, Inc.

Micrel Inc. • 2180 Fortune Drive • San Jose, CA 95131 • USA • tel +1 (408) 944-0800 • fax + 1 (408) 474-1000 • <http://www.micrel.com>

Getting Started

1. VIN Supply

Connect a supply to the VIN and GND terminals, paying careful attention to the polarity and the supply range ($7V < V_{IN} < 70V$). Monitor IIN with a current meter and monitor input voltage at VIN and GND terminals with a voltmeter. Do not apply power until step 4.

2. Connect Load and Monitor Output

Connect a load to the VOUT and GND terminals. The load can be either a passive (resistive) or an active (as in an electronic load) type. A current meter may be placed between the VOUT terminal and load to monitor the output current. Ensure the output voltage is monitored at the VOUT terminal.

3. Enable Input

The EN pin has an on board 100kΩ pull-up resistor (R16) to VIN, which allows the output to be turned on when PVDD exceeds its UVLO threshold. An EN connector is provided on the evaluation board for users to easily access the enable feature. Applying an external logic signal on the EN pin to pull it low or using a jumper to short the EN pin to GND will shut off the output of the MIC28304 evaluation board.

4. Turn Power

Turn on the VIN supply and verify that the output voltage is regulated to 5V.

Ordering Information

| Part Number | Description |
|-------------------|---|
| MIC28304-1 5V EV | MIC28304-1 Evaluation Board up to 5V Output |
| MIC28304-2 5V EV | MIC28304-2 Evaluation Board up to 5V Output |
| MIC28304-1 12V EV | MIC28304-1 Evaluation Board 12V Output |
| MIC28304-2 12V EV | MIC28304-2 Evaluation Board 12V Output |

Features

Feedback Resistors

The output voltage on the MIC28304 evaluation board, which is preset to 5.0V, is determined by the feedback divider:

$$V_{OUT} = V_{REF} \times \left(1 + \frac{R1}{R_{BOTTOM}} \right) \quad \text{Eq. 1}$$

where $V_{REF} = 0.8V$, and R_{BOTTOM} is one of R10, or R11, which corresponds to 3.3V, 5V. Leaving the R_{BOTTOM} open

gives a 0.8V output voltage. All other voltages not listed above can be set by modifying R_{BOTTOM} value according to:

$$R_{BOTTOM} = \frac{R1 \times V_{REF}}{V_{OUT} - V_{REF}} \quad \text{Eq. 2}$$

Note that the output voltage should not be set to exceed 5V due to the 6.3V voltage rating on the output capacitors. For higher output voltage, use the [Ordering Information](#) table. [Table 1](#) gives the typical values of some of the components, for details refer to Bill of Material table.

Table 1. Typical Values of Some Components

| V _{OUT} | V _{IN} | R3 (R _{inj}) | R1 (Top Feedback Resistor) | R11 (Bottom Feedback Resistor) | C10 (C _{inj}) | C12 (C _{ff}) | C _{OUT} |
|------------------|-----------------|---------------------------|-------------------------------|-----------------------------------|----------------------------|---------------------------|---------------------------|
| 0.9V | 5V to 70V | 16.5kΩ | 10kΩ | 80.6kΩ | 0.1μF | 2.2nF | 47μF /6.3V or 2 x 22μF |
| 1.2V | 5V to 70V | 16.5kΩ | 10kΩ | 20kΩ | 0.1μF | 2.2nF | 47μF /6.3V or 2 x 22μF |
| 1.8V | 5V to 70V | 16.5kΩ | 10kΩ | 8.06kΩ | 0.1μF | 2.2nF | 47μF /6.3V or 2 x 22μF |
| 2.5V | 5V to 70V | 16.5kΩ | 10kΩ | 4.75kΩ | 0.1μF | 2.2nF | 47μF /6.3V or 2 x 22μF |
| 3.3V | 5V to 70V | 16.5kΩ | 10kΩ | 3.24kΩ | 0.1μF | 2.2nF | 47μF /6.3V or 2 x 22μF |
| 5V | 7V to 70V | 16.5kΩ | 10kΩ | 1.9kΩ | 0.1μF | 2.2nF | 47μF/6.3V or 2 x 22μF |
| 12V | 18V to 70V | 23.2kΩ | 10kΩ | 715Ω | 0.1μF | 2.2nF | 47μF/16V or 2 x 22μF |

SW Node

Test point J1 (VSW) is placed for monitoring the switching waveform, which is one of the most critical waveforms for the converter.

Current Limit

The MIC28304 uses the $R_{DS(ON)}$ of the low-side MOSFET and external resistor connected from the ILIM pin to the SW node to decide the current limit.

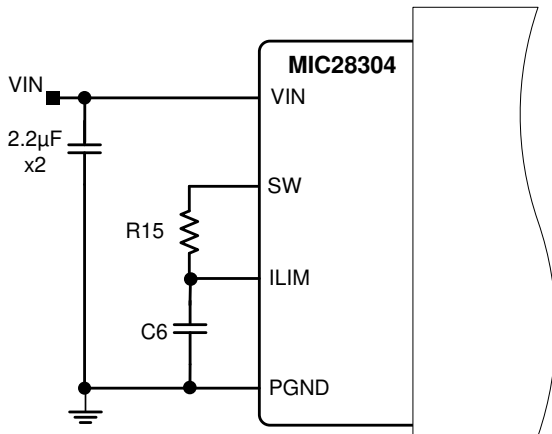

Figure 1. MIC28304 Current Limiting Circuit

In each switching cycle of the MIC28304, the inductor current is sensed by monitoring the low-side MOSFET in the OFF period. The sensed voltage $V(ILIM)$ is compared with the power ground (PGND) after a blanking time of 150ns. In this way the drop voltage over the resistor R15 (V_{CL}) is compared with the drop over the bottom FET generating the short current limit. The small capacitor (C6) connected from ILIM pin to PGND filters the switching node ringing during the off-time allowing a better short limit measurement. The time constant created by R15 and C6 should be much less than the minimum off time.

The V_{CL} drop allows programming of short limit through the value of the resistor (R15). If the absolute value of the voltage drop on the bottom FET is greater than V_{CL} . In that case the $V(ILIM)$ is lower than PGND and a short circuit event is triggered. A hiccup cycle to treat the short event is generated. The hiccup sequence including the soft start reduces the stress on the switching FETs and protects the load and supply for severe short conditions.

The short circuit current limit can be programmed by using the following formula:

$$R15 = \frac{(I_{CLIM} - \Delta I_{L(PP)} \times 0.5) \times R_{DS(ON)} + V_{CL}}{I_{CL}} \quad \text{Eq. 3}$$

I_{CLIM} = Desired current limit

$R_{DS(ON)}$ = On-resistance of low-side power MOSFET, 57mΩ typically

V_{CL} = Current-limit threshold (typical absolute value is 14mV per Electrical Characteristics Table in MIC28304 data sheet)

I_{CL} = Current-limit source current (typical value is 80µA, per the Electrical Characteristics table).

$\Delta I_{L(PP)}$ = Inductor current peak-to-peak, since the inductor is integrated use Equation 4 to calculate the inductor ripple current.

The peak-to-peak inductor current ripple is:

$$\Delta I_{L(PP)} = \frac{V_{OUT} \times (V_{IN(max)} - V_{OUT})}{V_{IN(max)} \times f_{sw} \times L} \quad \text{Eq. 4}$$

The MIC28304 has 4.7µH inductor integrated into the module. The typical value of $R_{WINDING(DCR)}$ of this particular inductor is in the range of 45mΩ.

In case of hard short, the short limit is folded down to allow an indefinite hard short on the output without any destructive effect. It is mandatory to make sure that the inductor current used to charge the output capacitance during soft start is under the folded short limit; otherwise the supply will go in hiccup mode and may not be finishing the soft start successfully.

The MOSFET $R_{DS(ON)}$ varies 30 to 40% with temperature. Therefore, it is recommended to add a 50% margin to I_{CLIM} in the above equation to avoid false current limiting due to increased MOSFET junction temperature rise. The following table shows typical output current limit value for a given R15 with C6 = 10pF.

| R15 | Typical Output Current Limit |
|--------|------------------------------|
| 1.81kΩ | 3A |
| 2.7kΩ | 6.3A |

Loop Gain Measurement

Resistor R14 is placed in series with the regulator feedback path. The control loop gain can be measured by connecting an impedance analyzer across the resistor and selecting the resistor value in between 20Ω to 50Ω.

Setting the Switching Frequency

The MIC28304 switching frequency can be adjusted by changing the value of resistor R19. The top resistor of 100kΩ is internal to module and is connected between VIN and FREQ pin, so the value of R19 sets the switching frequency. The switching frequency also depends on VIN, VOUT and load conditions.

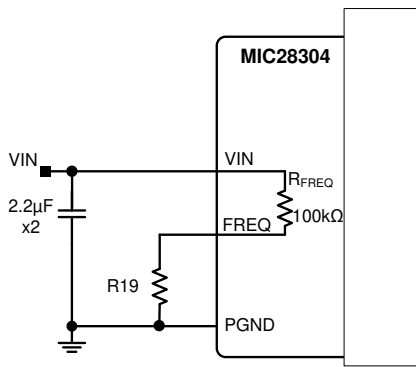

Figure 2. Switching Frequency Adjustment

The following formula gives the estimated switching frequency:

$$f_{SW_ADJ} = f_o \times \frac{R19}{R19 + 100k\Omega} \tag{Eq. 5}$$

Where f_o = Switching Frequency when R19 is open. For a more precise setting, it is recommended to use the following graph:

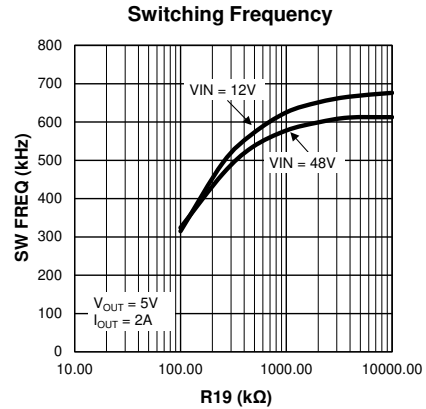
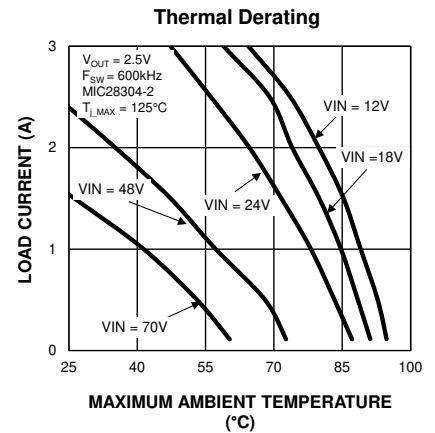
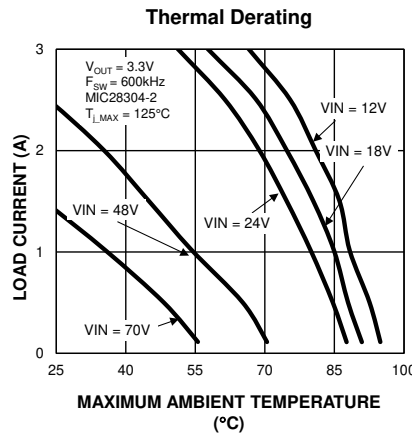
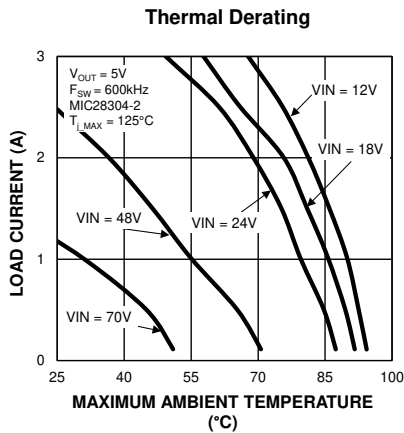
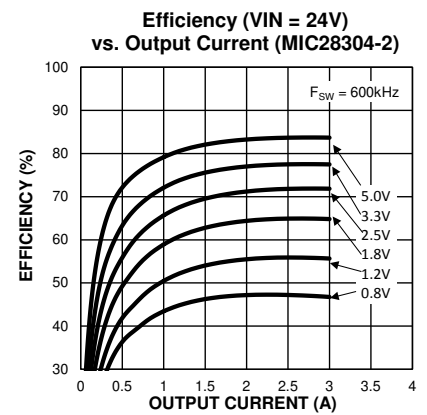
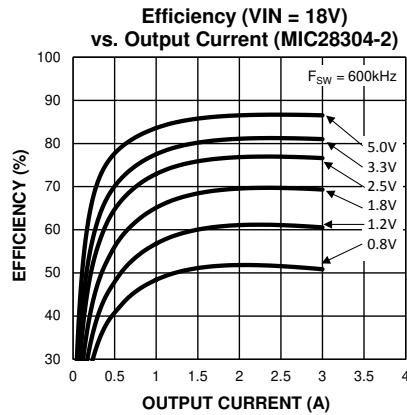
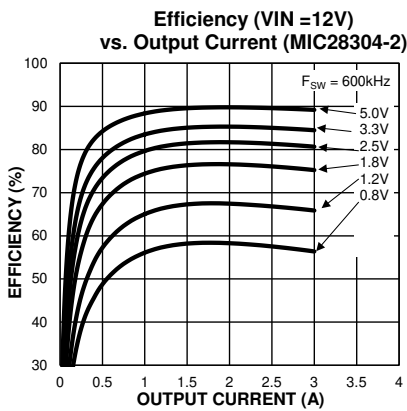
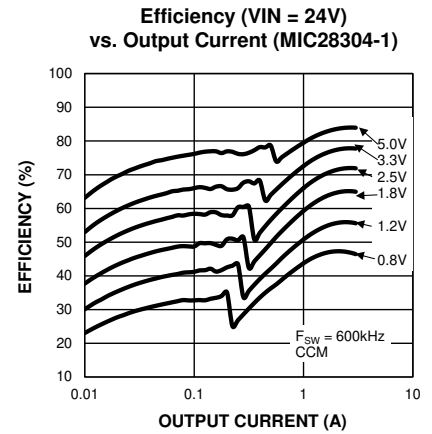
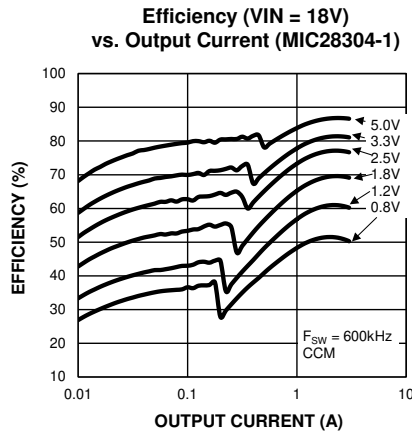
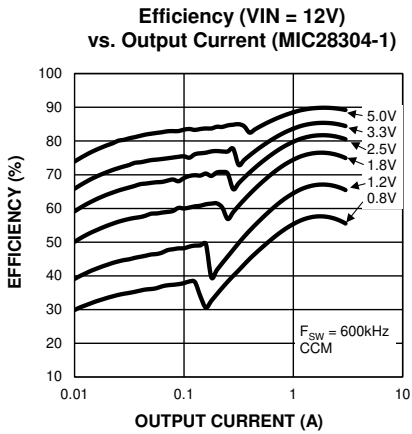

Figure 3. Switching Frequency vs. R19

MIC28304 0.8V to 5V/3A Evaluation Board Typical Characteristics



Die Temperature* : The temperature measurement was taken at the hottest point on the MIC28304 case mounted on a 5 square inch 4 layer, 0.62", FR-4 PCB with 2oz. finish copper weight per layer. Actual results will depend upon the size of the PCB, ambient temperature and proximity to other heat emitting components.

MIC28304 0.8V to 5V/3A Output Evaluation Board Schematic

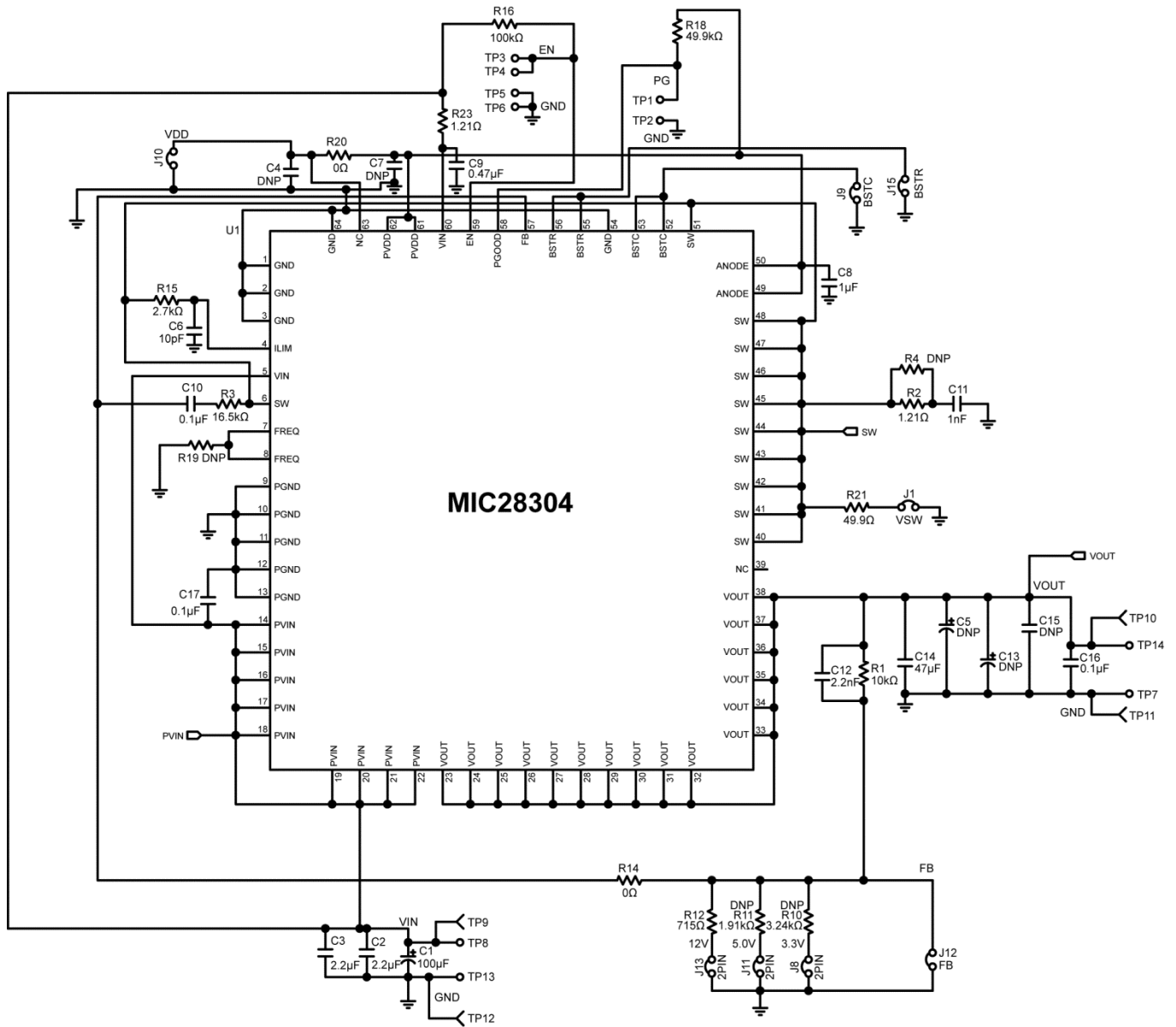

Figure 4. Schematic of MIC28304 Evaluation Board
 (J1, J8, J10, J11, J12, J13, R14, R20, and R21 are for testing purposes)

MIC28304 0.8V to 5V/3A Output Evaluation Board Schematic (Continued)

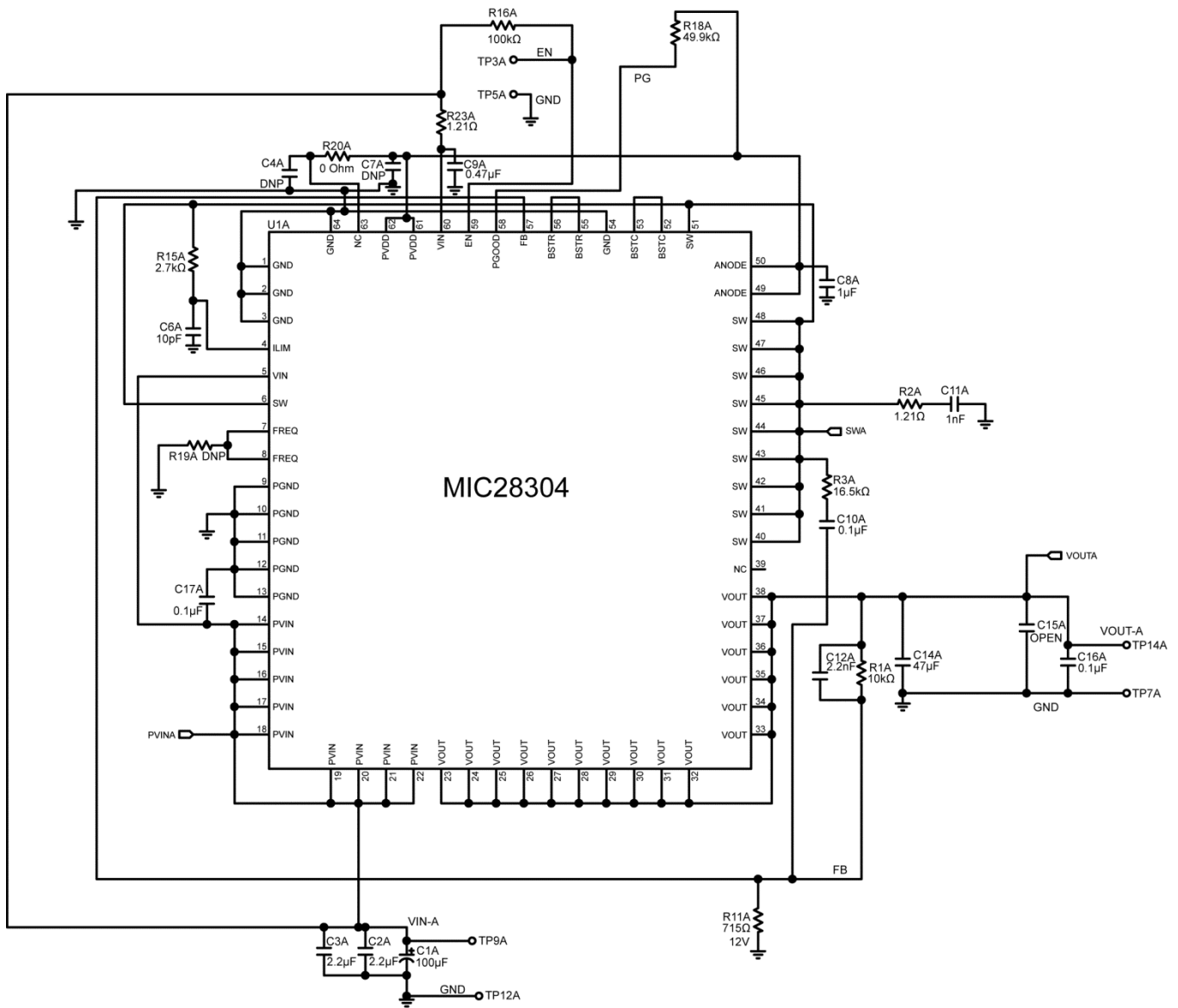

Figure 5. Schematic of MIC28304 Evaluation Board (Optimized for Smallest Footprint)

Bill of Materials 0.8V to 5V/3A Output

| Item | Part Number | Manufacturer | Description | Qty |
|--|--------------------|--------------------------|---|-----|
| C1, C1A ⁽²⁾ | EEU-FC2A101 | Panasonic ⁽³⁾ | 100 μ F Aluminum Capacitor, 100V | 2 |
| C2, C3, C2A ⁽²⁾ , C3A ⁽²⁾ | GRM32ER72A225K | Murata ⁽⁴⁾ | 2.2 μ F/100V Ceramic Capacitor, X7R, Size 1210 | 4 |
| | C3225X7R2A225K | TDK ⁽⁵⁾ | | |
| | 12101C225KAT2A | AVX ⁽⁶⁾ | | |
| C6, C6A ⁽²⁾ | GCM1885C2A100JA16D | Murata | 10pF, 100V, 0603, NPO | 2 |
| | 06031A100JAT2A | AVX | | |
| C8, C8A ⁽²⁾ | GRM188R70J105KA01D | Murata | 1 μ F/6.3V Ceramic Capacitor, X7R, Size 0603 | 2 |
| | 06036C105KAT2A | AVX | | |
| | C1608X5R0J105K | TDK | | |
| C9, C9A ⁽²⁾ | GRM21BR72A474KA73 | Murata | 0.47 μ F/100V Ceramic Capacitor, X7R, Size 0805 | 2 |
| | 08051C474KAT2A | AVX | | |
| C10, C17, C10A ⁽²⁾ , C17A ⁽²⁾ | GRM188R72A104KA35D | Murata | 0.1 μ F/100V Ceramic Capacitor, X7R, Size 0603 | 4 |
| | C1608X7S2A104K | TDK | 0.1 μ F/100V, X7S, 0603 | |
| C11, C11A ⁽²⁾ | GRM188R72A102KA01D | Murata | 1nF/100V Ceramic Capacitor, X7R, Size 0603 | 2 |
| | 06031C102KAT2A | AVX | | |
| | C1608X7R2A102K | TDK | | |
| C12, C12A ⁽²⁾ | GRM188R72A222KA01D | Murata | 2.2nF/100V Ceramic Capacitor, X7R, Size 0603 | 2 |
| | 06031C222KAT2A | AVX | | |
| | C1608X7R2A222K | TDK | | |
| C14, C14A ⁽²⁾ | GRM31CR60J476ME19K | Murata | 47 μ F/6.3V Ceramic Capacitor, X5R, Size 1210 | 2 |
| | 12106D476MAT2A | AVX | | |
| C16, C16A ⁽²⁾ | GRM188R71H104KA93D | Murata | 0.1 μ F/6.3V Ceramic Capacitor, X7R, Size 0603 | 2 |
| | 06035C104KAT2A | AVX | | |
| | C1608X7R1H104K | TDK | | |
| C4, C5, C7, C13, C15, C4A ⁽²⁾ , C7A ⁽²⁾ , C15A ⁽²⁾ | | | | DNP |

Notes:

2. Either reference designator, that is, a reference designator ending with "A" or ending without "A," can be used as part of customer design.
3. Panasonic: www.panasonic.com.
4. Murata: www.murata.com.
5. TDK: www.tdk.com.
6. AVX: www.avx.com.

Bill of Materials 0.8V to 5V/3A Output (Continued)

| Item | Part Number | Manufacturer | Description | Qty |
|-------------------------------|--|-----------------------------------|--|----------|
| R1, R1A ⁽²⁾ | CRCW060310K0FKEA | Vishay Dale ⁽⁷⁾ | 10k Ω Resistor, Size 0603, 1% | 2 |
| R2, R2A ⁽²⁾ | CRCW08051R21FKEA | Vishay Dale | 1.21 Ω Resistor, Size 0805, 5% | 2 |
| R3, R3A ⁽²⁾ | CRCW06031652F | Vishay Dale | 16.5k Ω Resistor, Size 0603, 1% | 2 |
| R10, | CRCW06033K24FKEA | Vishay Dale | 3.24k Ω Resistor, Size 0603, 1% | 1 |
| R11, R11A ⁽²⁾ | CRCW06031K91FKEA | Vishay Dale | 1.91k Ω Resistor, Size 0603, 1% | 2 |
| R12 | CRCW0603715R0FKEA | Vishay Dale | 715 Ω Resistor, Size 0603, 1% | DNP |
| R14, R20, R20A ⁽²⁾ | CRCW06030000FKEA | Vishay Dale | 0 Ω Resistor, Size 0603, 5% | 3 |
| R15, R15A ⁽²⁾ | CRCW04022K70JNED | Vishay Dale | 2.7k Ω Resistor, Size 0603, 1% | 2 |
| R16, R16A ⁽²⁾ | CRCW0603100KFKEAHP | Vishay Dale | 100k Ω Resistor, Size 0603, 1% | 2 |
| R18, R18A ⁽²⁾ | CRCW060349K9FKEA | Vishay Dale | 49.9k Ω Resistor, Size 0603, 1% | 2 |
| R21 | CRCW060349R9FKEA | Vishay Dale | 49.9 Ω Resistor, Size 0603, 1% | 1 |
| R23, R23A ⁽²⁾ | CRCW06031R21FKEA | Vishay Dale | 1.21 Ω Resistor, Size 0603, 1% | 2 |
| R4, R19, R19A ⁽²⁾ | | | | DNP |
| U1, U1A⁽²⁾ | MIC28304-1YMP MIC28304-2YMP | Micrel, Inc.⁽⁸⁾ | 70V, 3A Power Module | 2 |

Notes:7. Vishay: www.vishay.com.8. Micrel, Inc.: www.micrel.com.

MIC28304 0.8V to 12V/3A Evaluation Board Typical Characteristics

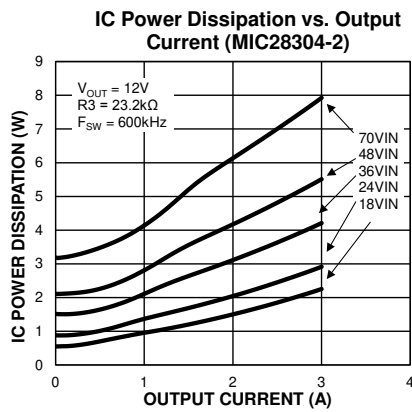
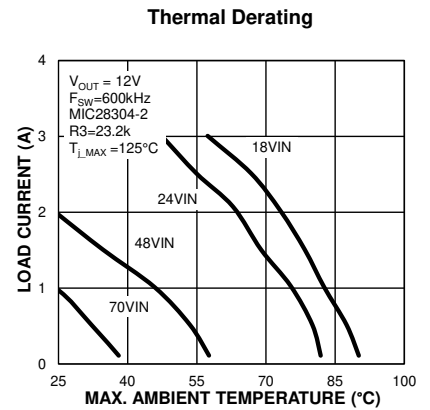
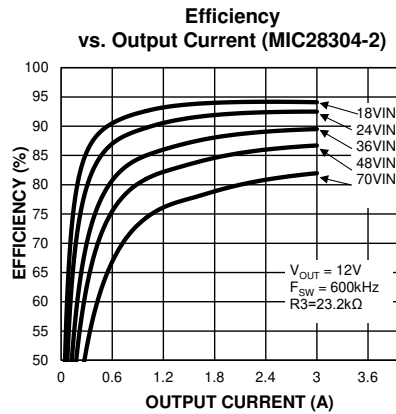
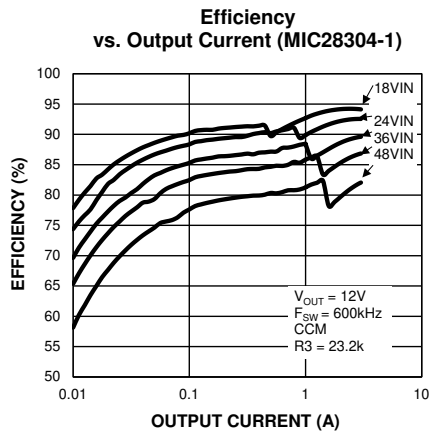

Die Temperature* : The temperature measurement was taken at the hottest point on the MIC28304 case mounted on a 5 square inch 4 layer, 0.62", FR-4 PCB with 2oz. finish copper weight per layer. Actual results will depend upon the size of the PCB, ambient temperature and proximity to other heat emitting components.

MIC28304 12V/3A Output Evaluation Board Schematic

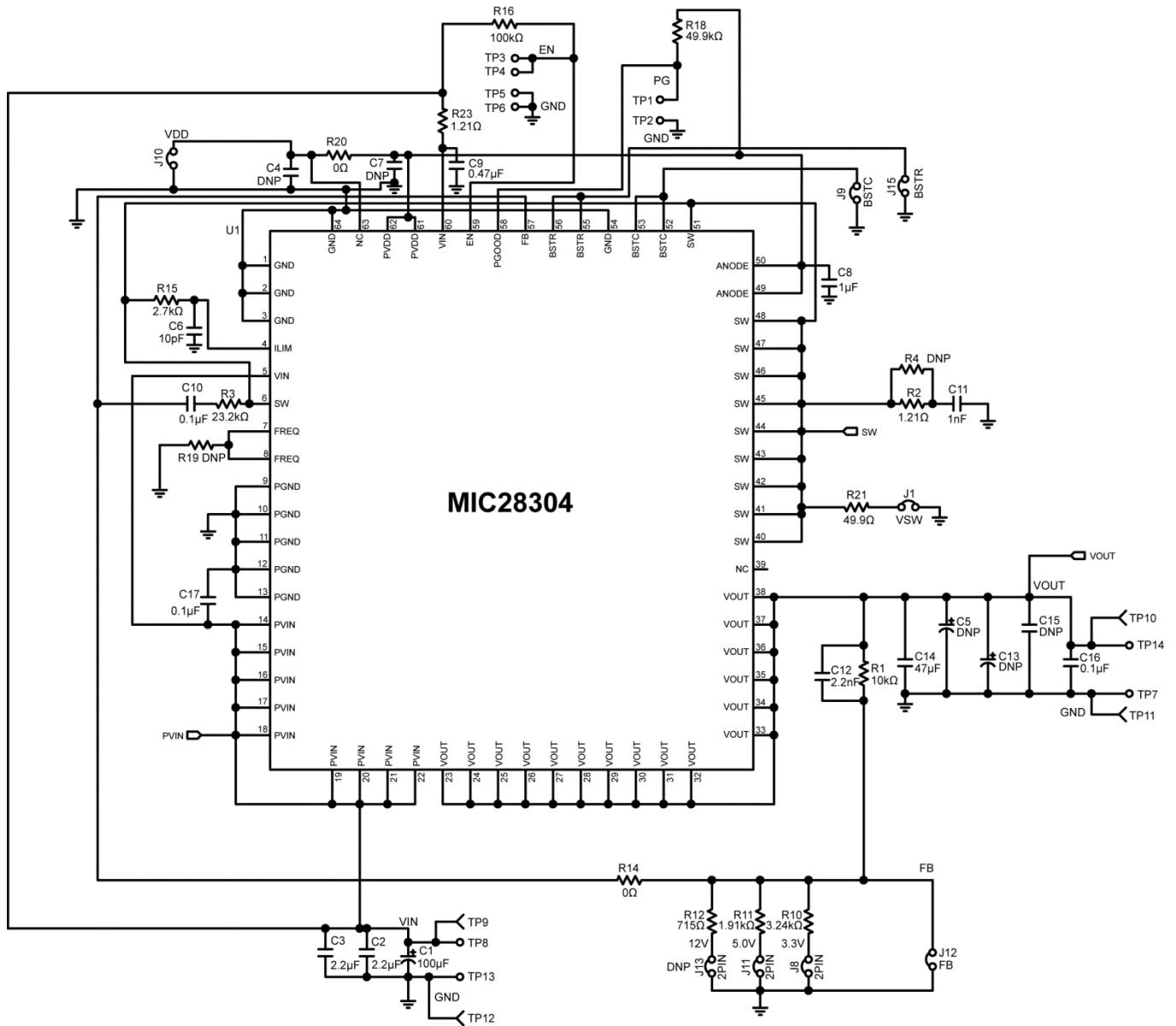

Figure 6. Schematic of MIC28304 Evaluation Board
 (J1, J8, J10, J11, J12, J13, R14, R20 and R21 are for testing purposes)

MIC28304 12V/3A Output Evaluation Board Schematic (Continued)

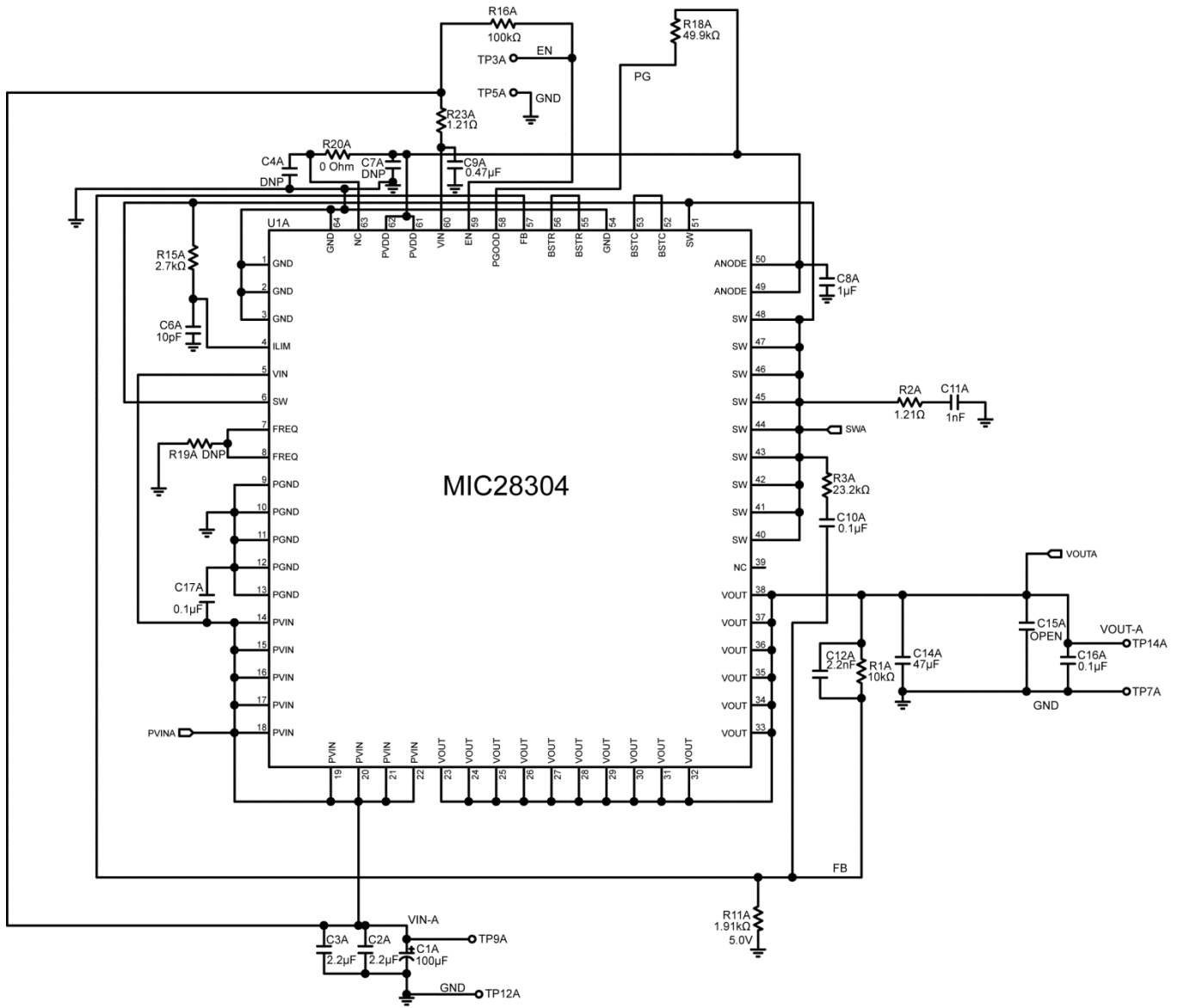

Figure 7. Schematic of MIC28304 Evaluation Board (Optimized for smallest footprint)

Bill of Materials 12V/3A Output

| Item | Part Number | Manufacturer | Description | Qty |
|--|--------------------|-----------------------------|---|-----|
| C1, C1A ⁽⁹⁾ | EEU-FC2A101 | Panasonic ⁽¹⁰⁾ | 100 μ F Aluminum Capacitor, 100V | 2 |
| C2, C3, C2A ⁽⁹⁾ , C3A ⁽⁹⁾ | GRM32ER72A225K | Murata ⁽¹¹⁾ | 2.2 μ F/100V Ceramic Capacitor, X7R, Size 1210 | 4 |
| | C3225X7R2A225K | TDK ⁽¹²⁾ | | |
| | 12101C225KAT2A | AVX ⁽¹³⁾ | | |
| C6, C6A ⁽⁹⁾ | GCM1885C2A100JA16D | Murata | 10pF, 100V, 0603, NPO | 2 |
| | 06031A100JAT2A | AVX | | |
| C8, C8A ⁽⁹⁾ | GRM188R70J105KA01D | Murata | 1 μ F/6.3V Ceramic Capacitor, X7R, Size 0603 | 2 |
| | 06036C105KAT2A | AVX | | |
| | C1608X5R0J105K | TDK | | |
| C9, C9A ⁽⁹⁾ | GRM21BR72A474KA73 | Murata | 0.47 μ F/100V Ceramic Capacitor, X7R, Size 0805 | 2 |
| | 08051C474KAT2A | AVX | | |
| C10, C17, C10A ⁽⁹⁾ , C17A ⁽⁹⁾ | GRM188R72A104KA35D | Murata | 0.1 μ F/100V Ceramic Capacitor, X7R, Size 0603 | 4 |
| | C1608X7S2A104K | TDK | 0.1 μ F/100V,X7S,0603 | |
| C11, C11A ⁽⁹⁾ | GRM188R72A102KA01D | Murata | 1nF/100V Ceramic Capacitor, X7R, Size 0603 | 2 |
| | 06031C102KAT2A | AVX | | |
| | C1608X7R2A102K | TDK | | |
| C12, C12A ⁽⁹⁾ | GRM188R72A222KA01D | Murata | 2.2nF/100V Ceramic Capacitor, X7R, Size 0603 | 2 |
| | 06031C222KAT2A | AVX | | |
| | C1608X7R2A222K | TDK | | |
| C14, C14A ⁽⁹⁾ | GRM32ER61C476ME15 | Murata | 47 μ F Ceramic Capacitor, X5R, Size 1210, 16V | 2 |
| | EMK325BJ476MM-T | Taiyo Yuden ⁽¹⁴⁾ | | |
| C16, C16A ⁽⁹⁾ | GRM188R71H104KA93D | Murata | 0.1 μ F/6.3V Ceramic Capacitor, X7R, Size 0603 | 2 |
| | 06035C104KAT2A | AVX | | |
| | C1608X7R1H104K | TDK | | |
| C4, C5, C7, C13, C15, C4A ⁽⁹⁾ , C7A ⁽⁹⁾ , C15A ⁽⁹⁾ | | | | DNP |

Notes:

9. Either reference designator, that is, a reference designator ending with "A" or ending without "A," can be used as part of customer design.
10. Panasonic: www.panasonic.com.
11. Murata: www.murata.com.
12. TDK: www.tdk.com.
13. AVX: www.avx.com.
14. Taiyo Yuden: www.taiyo-yuden.com.

Bill of Materials 12V/3A Output (Continued)

| Item | Part Number | Manufacturer | Description | Qty |
|---|--|------------------------------------|--|----------|
| R1, R1A ⁽⁹⁾ | CRCW060310K0FKEA | Vishay Dale ⁽¹⁵⁾ | 10k Ω Resistor, Size 0603, 1% | 2 |
| R2, R2A ⁽⁹⁾ | CRCW08051R21FKEA | Vishay Dale | 1.21 Ω Resistor, Size 0805, 5% | 2 |
| R3, R3A ⁽⁹⁾ | CRCW060323K2FKEA | Vishay Dale | 23.2k Ω Resistor, Size 0603, 1% | 2 |
| R12, R11A ⁽⁹⁾ | CRCW0603715R0FKEA | Vishay Dale | 715 Ω Resistor, Size 0603, 1% | 2 |
| R14, R20, R20A ⁽⁹⁾ | CRCW06030000FKEA | Vishay Dale | 0 Ω Resistor, Size 0603, 5% | 3 |
| R15, R15A ⁽⁹⁾ | CRCW04022K70JNED | Vishay Dale | 2.7k Ω Resistor, Size 0603, 1% | 2 |
| R16, R16A ⁽⁹⁾ | CRCW0603100KFKEAHP | Vishay Dale | 100k Ω Resistor, Size 0603, 1% | 2 |
| R18, R18A ⁽⁹⁾ | CRCW060349K9FKEA | Vishay Dale | 49.9k Ω Resistor, Size 0603, 1% | 2 |
| R21 | CRCW060349R9FKEA | Vishay Dale | 49.9 Ω Resistor, Size 0603, 1% | 1 |
| R23, R23A ⁽⁹⁾ | CRCW06031R21FKEA | Vishay Dale | 1.21 Ω Resistor, Size 0603, 1% | 2 |
| R4, R10, R11, R19, R19A ⁽⁹⁾ | | | | DNP |
| U1, U1A⁽⁹⁾ | MIC28304-1YMP MIC28304-2YMP | Micrel, Inc.⁽¹⁶⁾ | 70V, 3A Power Module | 2 |

Notes:15. Vishay: www.vishay.com.16. Micrel, Inc.: www.micrel.com.

PCB Layout Recommendations

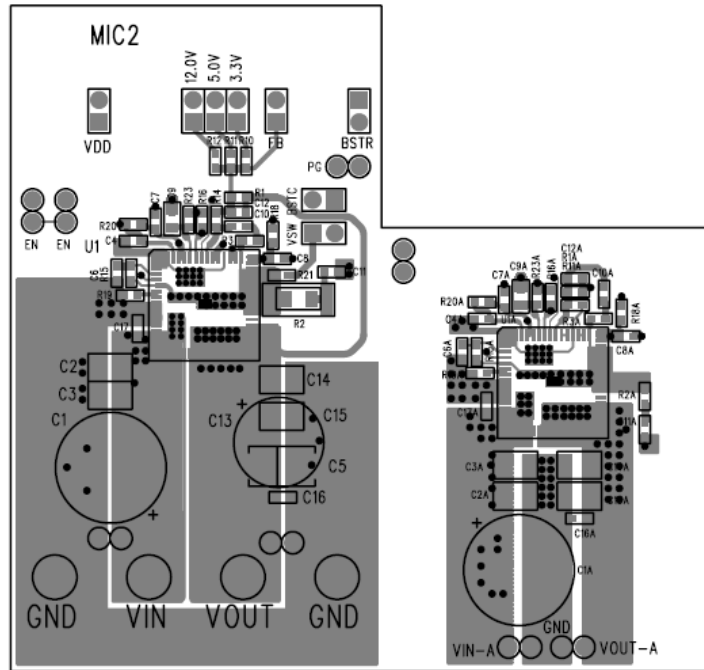

MIC28304 Evaluation Board Top Layer

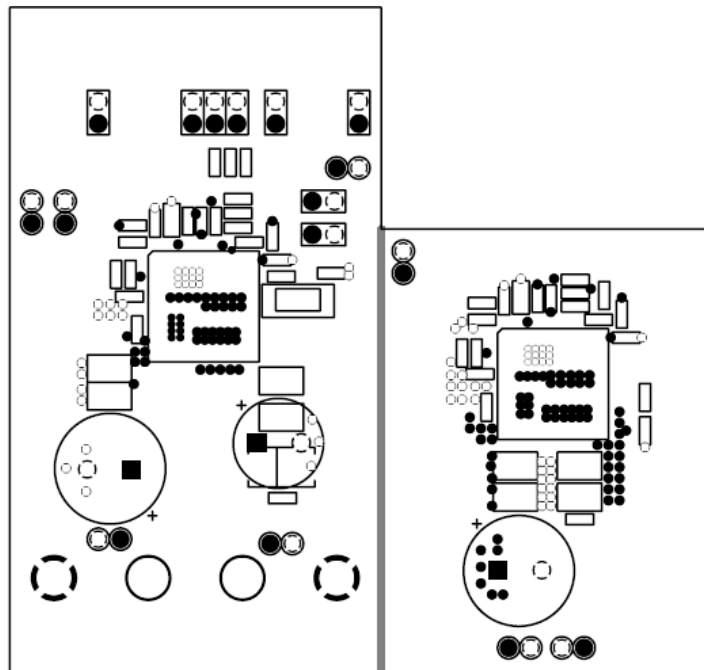

MIC28304 Evaluation Board Mid-Layer 1 (Ground Plane)

PCB Layout Recommendations (Continued)

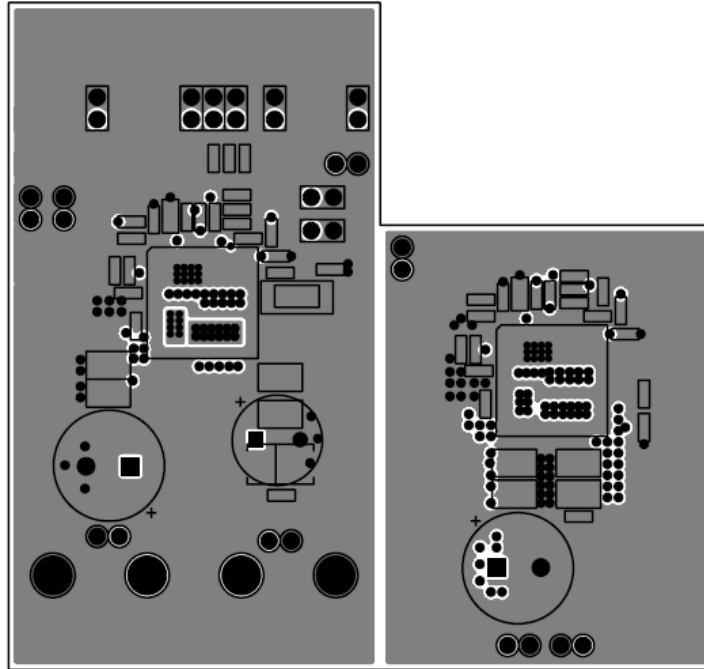

MIC28304 Evaluation Board Mid-Layer 2

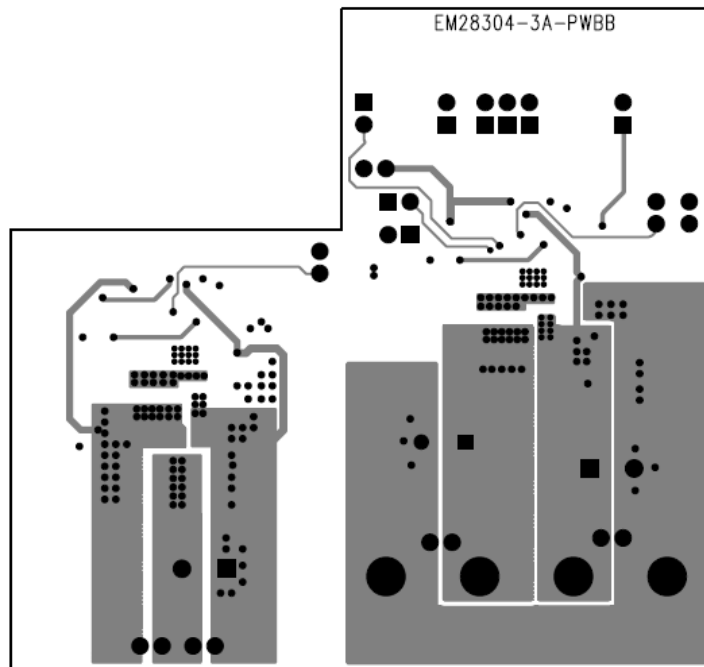

MIC28304 Evaluation Board Bottom Layer

MICREL, INC. 2180 FORTUNE DRIVE SAN JOSE, CA 95131 USATEL +1 (408) 944-0800 FAX +1 (408) 474-1000 WEB <http://www.micrel.com>

Micrel makes no representations or warranties with respect to the accuracy or completeness of the information furnished in this data sheet. This information is not intended as a warranty and Micrel does not assume responsibility for its use. Micrel reserves the right to change circuitry, specifications and descriptions at any time without notice. No license, whether express, implied, arising by estoppel or otherwise, to any intellectual property rights is granted by this document. Except as provided in Micrel's terms and conditions of sale for such products, Micrel assumes no liability whatsoever, and Micrel disclaims any express or implied warranty relating to the sale and/or use of Micrel products including liability or warranties relating to fitness for a particular purpose, merchantability, or infringement of any patent, copyright or other intellectual property right.

Micrel Products are not designed or authorized for use as components in life support appliances, devices or systems where malfunction of a product can reasonably be expected to result in personal injury. Life support devices or systems are devices or systems that (a) are intended for surgical implant into the body or (b) support or sustain life, and whose failure to perform can be reasonably expected to result in a significant injury to the user. A Purchaser's use or sale of Micrel Products for use in life support appliances, devices or systems is a Purchaser's own risk and Purchaser agrees to fully indemnify Micrel for any damages resulting from such use or sale.

© 2014 Micrel, Incorporated.

Revision History

| Date | Change Description/Edits by: | Rev. |
|---------|------------------------------|------|
| 2/15/14 | New Eval Board literature | 1.0 |
| | | |
| | | |
| | | |