

LMP-1600G-M12-67-110 Series

16-Port Industrial M12 IP67 Waterproof Gigabit PoE+ Light Layer 3 Managed Ethernet Switch, with 16*10/100/1000Tx M12 Connectors (X-Coded) (30W/Port); 24~110VDC Power Input

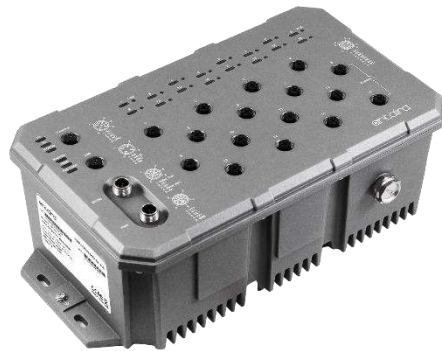

Features

- ▶ 16-Port 10/100/1000Base-T(X) Ethernet with IEEE 802.3af/at compliant (30W/Port)
- ▶ Multi-user Account for Security
- ▶ Bypass Design for Daisy Chain Redundancy
- ▶ Configuration: http, https, CLI Command, Telnet, SNMP, SSH
- ▶ Network Redundancy Support: G.8032 ERPS v2 / STP / RSTP / MSTP
- ▶ Supports Static Routes for Routing Function
- ▶ Supports RADIUS, TACACS+ Authentication Protocol
- ▶ Supports QoS, LACP Bandwidth Control
- ▶ Supports VLAN, SNMP v1/v2c/v3, ACL, IP Source Guard for Ethernet Security
- ▶ PoE Ping Alarm Function for PoE Ports Power Recycle
- ▶ Redundant Power Inputs Design
- ▶ Operating Temperature Range
 - STD: -10°C to 65°C, EOT: -40°C to 70°C
- ▶ 5-Year Warranty

INTRODUCTION

Antaira Technologies' LMP-1600G-M12-67-110 Series is a 16-port managed gigabit Ethernet switch, which provides 16*10/100/1000 Base-T(X) with IEEE 802.3 af/at PoE compliant. The LMP-1600G-M12-67-110 Series is fully-manageable light layer 3 Ethernet switch series and supports power input redundancy. It also offers network redundancy ITU-T G.8032 ERPS v2 (Ethernet Ring Protection Switch) protocol, providing <50ms recovery time to the network.

The LMP-1600G-M12-67-110 Series provides comprehensive network security and management capability by supporting multi-user accounts, IGMP, GVRP, VLAN, QoS, SNMP, RADIUS, TACACS+, Aggregation (Static, LACP), SSH, SSL, IP source guard to create a highly-secured network environment. For power saving purposes, assuring PD priority, and enhancing security level of the network. The LMP-1600G-M12-67-110 Series also supports PoE scheduling and PoE output limit function to set up PoE output duration and watt at will.

The LMP-1600G-M12-67-110 Series is an M12 IP67 PoE+ industrial gigabit Ethernet switch that meets the high-reliability requirements demanded by industrial applications. Its M12 connectors ensure a tight and robust connection to guarantee reliable operation on applications subject to high vibration and shock in dust, liquid, or gas-laden environments. It can operate under the standard temperature range from -10°C to 65°C or extended temperature range from -40°C to 70°C, useful in almost any harsh environment.

DIMENSIONS

Unit: mm (inch)

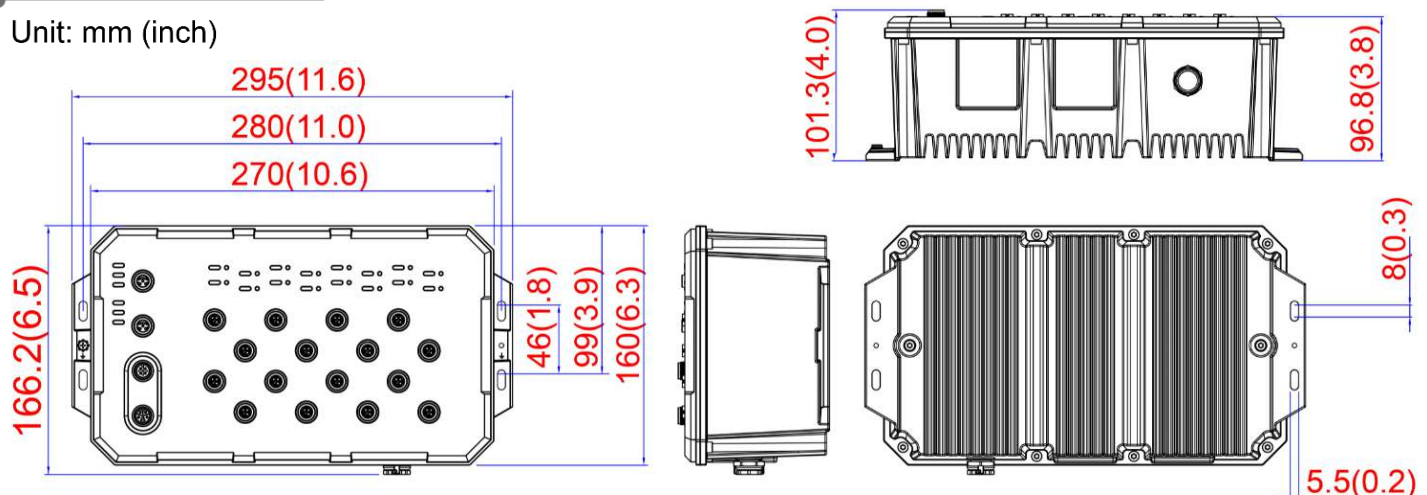

SPECIFICATIONS

Technology	
L2 Switching	Port/MAC/Protocol/IP Subnet-based VLAN, GARP/GVRP, Loop Guard, Link Aggregation static/LACP, BPDU guard, Error disable recovery, IGMP snooping v2/v3, MLD snooping v1/v2, IGMP filtering, IPMC throttling / filtering leave proxy, DHCP snooping, G.8032 v1/v2
L3 Switching	DHCP option82, static routes
QoS	802.1p Queueing, Input priority mapping, Storm control for Unicast/Multicast/Broadcast, Port/Queue/ACL policer, Port egress shaper, Queue egress shaper, DiffServ (DSCP), Tag remarking, Scheduler mode
Power Saving	ActiPHY, PerfectReach, IEEE 802.3az EEE power management
Network Redundancy	STP/RSTP/MSTP, port trunk with LACP, ERPS v1/v2 (<50ms)
Configuration System / Diagnostics	Http, Https, Telnet, SSH, CLI, TFTP, SNMP v3
Switch Properties	
Switch Architecture	Back-Plane (Switching Fabric): 32Gbps
Priority Queues	8
Processing Type	Store and forward
Flow Control	IEEE 802.3x flow control, back pressure flow control
Transfer Rate	14,880pps for Ethernet Port 148,800pps for Fast Ethernet Port 1,488,000pps for Gigabit Ethernet Port
Memory Buffer	4Mbits
Jumbo Frame	9.6Kbytes
MAC Table Size	32K
VLAN Group	4095
IGMP Group	1024
Port Interface	
Ethernet Port	16*10/100/1000 Base-T(X), 8-pin M12 X-Coded female connectors, auto negotiation speed, Full/Half duplex mode, and auto MDI/MDI-X connection
RS232 Serial Console	1*RS232 with M12 5-pin A-coded female connector
Configuration Backup	1*USB 2.0 with M12 4-pin A-coded female connector for configuration backup/restore 1* Digital Input (DI) with M12 5-Pin A-coded male connector: State 0: -30~8VDC / State 1: 10~30VDC, Max. input current: 8mA
DI	
Bypass Protection	Ethernet Port 8 and Port 16
LED Indicators	System: Power 1, Power 2, Master, Ring, Status, PoE Load PoE: On-connected to PD devices Ethernet ports: Speed/Link/Active

Protection	
Network Cable	10Base-T: 2-pair UTP/STP Cat. 3, 4, 5 cable EIA/TIA-568 100-ohm (100m) 100Base-TX: 2-pair UTP/STP Cat. 5 cable EIA/TIA-568 100-ohm (100m) 1000Base-T: 4-pair UTP/STP Cat.5/5E cable; EIA/TIA-568 100-ohm (100m)
Mechanical Characteristics	
Housing	Metal, IP67 protection
Dimensions	166.2 x 295 x 101.3 mm (W x H x D) Unit: 9.42 lbs. Shipping: 11.01 lbs.
Weight	
Mounting	Wall mounting
Power Requirement	
Input Voltage	24~110VDC Redundant Input
Power Connection	Dual DC power inputs through M12 5-pin K-coded male connector
Relay Contact	24VDC, 1A resistive
Overload Current Protection	Present
Reverse Polarity Protection	Present
PoE Pin Assignment	V+, V+, V-, V-, for pin 1, 2, 3, 6 (End-span, Mode A)
PoE Power Budget	120W
System Power Consumption	45W
Environmental Limits	
Operating Temperature	STD: -10°C to 65°C EOT: -40°C to 70°C
Storage Temperature	-40°C to 85°C
Ambient Relative Humidity	5% to 95%, (non-condensing)
Regulatory Approvals	
EMI	FCC Part 15 Subpart B Class A, CE EN55032/EN61000-6-4 Class A
EMS	CE EN55035/EN61000-6-2: IEC61000-4-2,3,4,5,6,8
Free Fall	IEC60068-2-32
Shock	IEC60068-2-27
Vibration	IEC60068-2-6
Green	RoHS Compliant
Certifications	FCC, CE
Warranty	5 Years

ORDERING INFO

LMP-1600G-M12-67-110	16-Port Industrial M12 IP67 Waterproof Gigabit PoE+ Light Layer 3 Managed Ethernet Switch, with 16*10/100/1000Tx M12 Connectors (X-Coded) (30W/Port), 24-110VDC Power Input, STD: -10°C to 65°C
LMP-1600G-M12-67-110-T	16-Port Industrial M12 IP67 Waterproof Gigabit PoE+ Light Layer 3 Managed Ethernet Switch, with 16*10/100/1000Tx M12 Connectors (X-Coded) (30W/Port), 24-110VDC Power Input, EOT: -40°C to 70°C

Optional Accessories

CB-M12A5PF-5M	M12 A Code 5P Female to open wire, 5 Meter, Wire: 22 AWG, DI/DO Cable
CB-M12A4PM-USB-5M	M12 A Code 4P Male to USB 2.0 Type-A Female, 5 Meter, Wire: 28 AWG, USB Cable
CB-M12X8PM-RJ45-5M	M12 X Code 8P Male to RJ-45 Socket, 5 Meter, Wire: 26 AWG, Ethernet Cable
CB-M12K5PF-5M	M12 K Code 5P Female to open wire, 5 Meter, Wire: 14 AWG, Power Cable
CB-M12A5PM-DB9-5M	M12 A Code 5P Male to DB9 Female, 5 Meter, Wire: 24 AWG, Console Cable