

LOC	DIST	REVISIONS					
DF	AO	P	LTR	DESCRIPTION	DATE	DWN	APVD
		0		DRAWN PER DR 8-067F	26JUN98	TT	SG

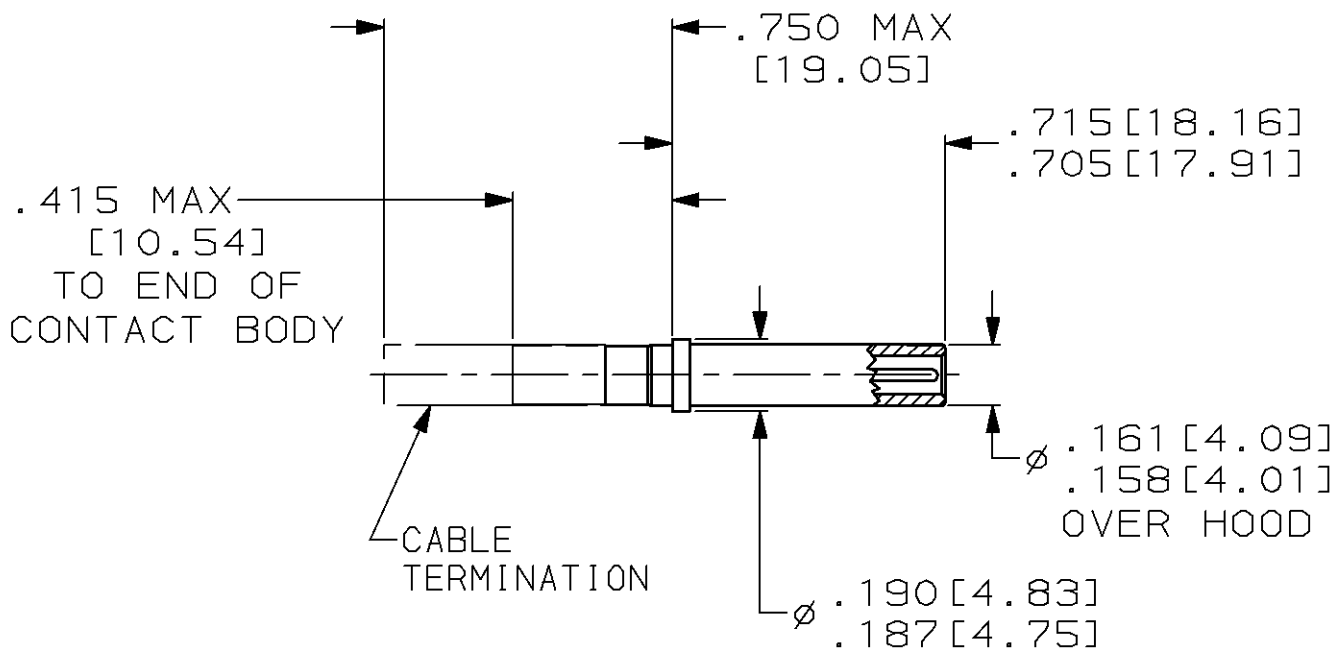

- CONTACT PER MIL-C-39029/73.
- FOR USE IN MIL-C-83723 SERIES III, MIL-C-26482 SERIES 2, MIL-C-83733 AND DOD-C-83527 CONNECTORS.
- MATES WITH AMP PART NUMBER 213156-1 (MIL-C-39029/74).

213157-1
PART NUMBER

DIMENSIONS: [InCmm]	DWN	26JUN98	MATERIAL	-	FINISH	-	
	CHK	T. THOMPSON	26JUN98	AMP Incorporated Harrisburg, PA 17105-3608			
TOLERANCES UNLESS OTHERWISE SPECIFIED:	APVD	S. GLATFELTER	26JUN98				
0 PLC ±-	PRODUCT SPEC	S. GLATFELTER	26JUN98	NAME			
1 PLC ±-	APPLICATION SPEC	-	-	SOCKET CONTACT, SOLDER, SIZE 12, SHIELDED			
2 PLC ±-	WEIGHT	-	-	SIZE	CAGE CODE	DRAWING NO	
3 PLC ±.005 [0.13]				A4	00779	C= 213157	
4 PLC ±-				RESTRICTED TO			
ANGLES ±-				-			
CUSTOMER DRAWING				SCALE	2:1	SHEET 1 OF 1	REV 0

THIS DRAWING IS UNPUBLISHED. ALL RIGHTS RESERVED. BY AMP INCORPORATED. COPYRIGHT 1988